



Installation Manual

**Self-Powered Truck Edition
Multi-Temperature Systems**
T-1090 SPECTRUM Series

Revision C

August 2020

TK 56701-1-IM-EN

TRANE
TECHNOLOGIES

Introduction

This manual was written to assist with the installation of Thermo King T1090 SPECTRUM condensing unit and SPECTRUM remote evaporators onto truck bodies specifically designed and built for multi-temperature refrigerated applications. Separate installation instructions for Thermo King options (e.g., door switches, status light, fuel tanks, etc.) can be found at www.thermoking.com.

Due to its complexity, you should not attempt this installation unless you:

- Are an experienced mechanic.
- Can safely lift 34 kilos (75 lbs.).
- In the U.S., EPA 608 certified and trained in the repair and maintenance of transport refrigeration systems.
- Have a basic understanding of electricity and electrical wiring.
- Have the necessary tools and equipment to complete the installation.
- Have a truck body designed and built to meet the requirements of this installation.
- Follow all safety precautions outlined in this manual.

This manual is published for informational purposes only. Thermo King makes no representations warranties express or implied, with respect to the information recommendations and descriptions contained herein. Information provided should not be regarded as all-inclusive or covering all contingencies. If further information is required, Thermo King Corporation Service Department should be consulted.

Thermo King's warranty shall not apply to any equipment which has been "so installed, maintained, repaired or altered as, in the manufacturer's judgment, to affect its integrity."

Manufacturer shall have no liability to any person or entity for any personal injury, property damage or any other direct, indirect, special, or consequential damages whatsoever, arising out of the use of this manual or any information, recommendations or descriptions contained herein. The procedures described herein should only be undertaken by suitably qualified personnel. Failure to implement these procedures correctly may cause damage to the Thermo King unit or other property or personal injury.

Revision History

Revision A	(09/19) New manual.
Revision B	(01/20) Corrected mounting hole dimension and added information on installing unit without nut plates.
Revision C	(08/20) Added information for EPA conformance regarding attaching label near fuel tank stating "ULTRA-LOW-SULFUR FUEL ONLY"

Customer Satisfaction Survey

Let your voice be heard!

Your feedback will help improve our manuals. The survey is accessible through any internet-connected device with a web browser.

Scan the Quick Response (QR) code or click or type the web address https://tranetechnologies.iad1.qualtrics.com/jfe/form/SV_2octfSHoUJxsk6x?Q_CHL=qr&Q_JFE=qdg to complete the survey.



Table of Contents

Safety Precautions	6
Danger, Warning, Caution, and Notice	6
General Practices	6
Refrigerant Hazards	7
Refrigerant Oil Hazards.....	7
First Aid.....	7
Unit Installation Hazards.....	8
Fuel System Component Installation Hazards	9
Battery Installation and Cable Routing Hazards.....	10
SPECTRUM Selection Guide	11
Returnable Steel Crate Information	12
Overview.....	12
Crate Breakdown Procedures	13
Important Storing and Return Shipping Information	14
Dimensions	15
Unit Dimensions and Weights	15
Unit Service Area Dimensions	16
Truck Body Opening Dimensions.....	17
Evaporator Dimensions and Weights	18
Unit Lifting Bar Dimensions.....	22
HMI Controller Dimensions	27
Standby Power Receptacle Dimensions (OPTION)	28
Required Tools	30
Condensing Unit Installation Components	32
Installing Condensing Unit	34
Unit Mounting Bolt Requirements.....	34
Uncrating Procedures	36
Installation Procedures.....	37
Securing Oil Drain Hose	39
Installing USB Download Port (OPTION)	40
Securing Standby Power Receptacle (OPTION)	41
Installing HMI Controller	42
Installing Fuel Pickup Tube	43

Steel or Aluminum Tank.....	43
Plastic Tank	44
Installing Fuel Pump and Fuel Lines.....	45
Evaporator Installation Standards	46
Evaporator Locations	46
Evaporator Defrost Drains	47
Cargo Wall Drain Tubes.....	47
Refrigerant Tubing and Electrical Wiring	48
Refrigeration Tubing	48
Electrical Wiring.....	48
Wall and Ceiling Troughs.....	49
Drain Hose Resistance Wire Installation Guide	50
Defrost Drain Tube Connectors	53
Transverse Drain (Option)	54
Evaporator Cap Plugs	54
Removing the Holding Charge	55
Condensing Unit	55
Remote Evaporators.....	55
Evaporator Installation Components	56
Basic S-2 and S-3 Installation Components.....	56
Two and Three Zone S-2 or S-3 Installation Components.....	58
Two Zone S-2 + S-2 Installation Components.....	60
Installing Evaporators	62
Ceiling Preparation	62
Mounting Stud or Bolt Requirements.....	62
S-2 or S-3 Evaporator Installation	62
Refrigeration Tubing Connections	64
S-2 or S-3 Installations	64
Connections at Condensing Unit.....	64
Connections at Evaporator.....	66
S-2 + S-2 Installations	67
Connections at Condensing Unit.....	67
Connections at Evaporator.....	69
Three Zone Installations.....	70
Connections at Condensing Unit.....	70
Connections at Evaporator.....	72
Wire Connections	73

S-2 or S-3 Installations	73
S-2 + S-2 Installations	75
Three Zone Installations	77
Evaporator Drain Hose Installation.....	79
Drain Hose Resistance Wires.....	79
Drain Hose Requirements	79
Installing Cap Plugs and Evaporator Covers	83
Battery Connections	84
Auxiliary Electrical Accessories	86
TracKing (OPTION).....	86
System Leak Check Procedures.....	87
Set-up Unit.....	87
Leak Check the System	87
System Evacuation	89
System Charging	91
Commissioning and PDI Forms.....	93
Commissioning Form Overview.....	93
Pre-Delivery Inspection (PDI) Form Overview.....	97

Safety Precautions

Danger, Warning, Caution, and Notice

Safety advisories appear throughout this manual as required. Your personal safety and the proper installation of this unit depend upon the strict observance of these precautions.

⚠ DANGER

Indicates an imminently hazardous situation which, if not avoided, will result in death or serious injury.

⚠ WARNING

Indicates a potentially hazardous situation which, if not avoided, could result in death or serious injury.

⚠ CAUTION

Indicates a potentially hazardous situation which, if not avoided, could result in minor or moderate injury and unsafe practices.

NOTICE

Indicates a situation that could result in equipment or property-damage only accidents.

General Practices

⚠ DANGER**Hazardous Gases!**

Refrigerant in the presence of an open flame, spark, or electrical short produces toxic gases that are severe respiratory irritants which can cause serious injury or possible death.

⚠ DANGER**Refrigerant Vapor Hazard!**

Do not inhale refrigerant. Use caution when working with refrigerant or a refrigeration system in any confined area with a limited air supply. Refrigerant displaces air and can cause oxygen depletion, resulting in suffocation and possible death.

⚠ DANGER**Risk of Injury!**

Keep your hands, clothing, and tools clear of fans and/or belts when working on a unit that is running or when opening or closing compressor service valves. Loose clothing might entangle moving pulleys or belts, causing serious injury or possible death.

⚠ WARNING**Hazard of Explosion!**

Never close the compressor discharge service valve when the unit is operating. Never operate the unit with the discharge valve closed (front seated). This condition increases internal pressure, which can cause an explosion.

⚠ WARNING**Personal Protective Equipment (PPE) Required!**

Always wear goggles or safety glasses when working on a unit. Refrigerant liquid, oil, and battery acid can permanently damage your eyes. See "First Aid".

Refrigerant Hazards

⚠ WARNING

Personal Protective Equipment (PPE) Required!

Refrigerant in a liquid state evaporates rapidly when exposed to the atmosphere, freezing anything it contacts. Wear butyl lined gloves and other clothing and eye wear when handling refrigerant to help prevent frostbite.

Refrigerant Oil Hazards

⚠ WARNING

Personal Protective Equipment (PPE) Required!

Protect your eyes from contact with refrigerant oil. The oil can cause serious eye injuries. Protect skin and clothing from prolonged or repeated contact with refrigerant oil. To prevent irritation, wash your hands and clothing thoroughly after handling the oil. Rubber gloves are recommended.

First Aid

REFRIGERANT

- **Eyes:** For contact with liquid, immediately flush eyes with large amounts of water and get prompt medical attention.
- **Skin:** Flush area with large amounts of warm water. Do not apply heat. Remove contaminated clothing and shoes. Wrap burns with dry, sterile, bulky dressing to protect from infection. Get prompt medical attention. Wash contaminated clothing before reuse.
- **Inhalation:** Move victim to fresh air and use CPR (cardio pulmonary resuscitation) or mouth-to-mouth resuscitation to restore breathing, if necessary. Stay with victim until emergency personnel arrive.
- **Frost Bite:** In the event of frost bite, the objectives of First Aid are to protect the frozen area from further injury, warm the affected area rapidly, and to maintain respiration.

REFRIGERANT OIL

- **Eyes:** Immediately flush with large amounts of water for at least 15 minutes. Get prompt medical attention.
- **Skin:** Remove contaminated clothing. Wash thoroughly with soap and water. Get medical attention if irritation persists.
- **Inhalation:** Move victim to fresh air and use CPR (cardio pulmonary resuscitation) or mouth-to-mouth resuscitation to restore breathing, if necessary. Stay with victim until emergency personnel arrive.
- **Ingestion:** Do not induce vomiting. Immediately contact local poison control center or physician.

ENGINE COOLANT

- **Eyes:** Immediately flush with large amounts of water for at least 15 minutes. Get prompt medical attention.
- **Skin:** Remove contaminated clothing. Wash thoroughly with soap and water. Get medical attention if irritation persists.
- **Ingestion:** Do not induce vomiting. Immediately contact local poison control center or physician.

ELECTRICAL SHOCK

Take IMMEDIATE action after a person has received an electrical shock. Get quick medical assistance, if possible.

The source of the shock must be quickly stopped, by either shutting off the power or removing the victim. If the power cannot be shut off, the wire should be cut with a non-conductive tool, such as a wood-handle axe or thickly insulated cable cutters. Rescuers should wear insulated gloves and safety glasses, and avoid looking at wires being cut. The ensuing flash can cause burns and blindness.

If the victim must be removed from a live circuit, pull the victim away with a non-conductive material. Use wood, rope, a belt or coat to pull or push the victim away from the current. DO NOT TOUCH the victim. You will receive a shock from current flowing through the victim's body. After separating the victim from power source, immediately check for signs of a pulse and respiration. If no pulse is present, start CPR (cardio pulmonary resuscitation). If a pulse is present, respiration might be restored by using mouth-to-mouth resuscitation. Call for emergency medical assistance.



Unit Installation Hazards

⚠ DANGER

Fire Hazard!

Never bundle evaporator drain hose resistance wires together as the amount of heat produced could result in a fire!

⚠ WARNING

Equipment Damage and Risk of Injury!

Improper lifting of a refrigeration unit during installation can be dangerous. Thermo King requires a 3 point lifting bar to safely lift and install units. A lifting bar can be made from the drawings provided, however, all hardware used to assemble the lifting bar must be DIN 931 class 10.9 (SAE grade 8). The use of hardware other than specified may cause personal injury, severe damage to the equipment and void the warranty. All clevises, clevis pins and chain links must be forged steel with strength equal to the total lift capacity of hoist mechanism and that meet all safety standards.

⚠ WARNING

Equipment Damage and Risk of Injury!

Lifting and stacking refrigeration units in returnable steel crates can be dangerous. Forklifts must have the rated capacity to handle the combined weight of the refrigeration unit and the steel crate. Forklifts must also have the rated capacity to safely raise and stack crated units to a maximum of five (5) high.

⚠ WARNING

Equipment Damage and Risk of Injury!

Lifting, stacking and moving empty returnable steel crates can be dangerous. Empty steel crates can be stacked a maximum of twelve (12) high for storage. Forklifts must have the rated capacity to safely reach these heights while lifting an empty steel crate. When returning steel crates, they must be stacked a maximum of eight (8) high. Forklifts must have the rated capacity to safely raise and move a stack of eight (8) steel crates.

⚠ WARNING

Equipment Damage and Risk of Injury!

Never drill holes into the unit unless instructed by Thermo King. Holes drilled into high voltage cables could cause an electrical fire, severe personal injury, or even death.

⚠ WARNING

Risk of Injury!

When using ladders to install or service refrigeration systems, always observe the ladder manufacturer's safety labels and warnings. A work platform or scaffolding is the recommended method for installations and servicing.

⚠ CAUTION

Risk of Injury!

Thermo King Multi-Temperature SPECTRUM truck condensing units and SPECTRUM remote evaporators are shipped with a 35–69 kPa (5–10 psi) holding charge of nitrogen. This holding charge may be safely vented into the atmosphere by carefully removing the ORS caps from the condensing unit and unsoldering the caps from the evaporators. Always wear goggles or safety glasses when removing the refrigeration tubing caps.

NOTICE**Compressor Damage!**

SEVERE COMPRESSOR DAMAGE will result from operating the unit before completing the installation which includes: installing the components, releasing the holding charge, connecting refrigeration lines, leak testing, evacuation, clean-up, and charging of the system with the proper amount and type of refrigerant.

NOTICE**Equipment Damage!**

All mounting bolts must be the correct length for their applications and torqued to specification. Incorrect bolt lengths and improper torque specifications can damage equipment.

NOTICE**Equipment Damage!**

Cargo box ceiling must be structurally strong enough to support the weight of the SPECTRUM evaporator(s). Additional installer supplied supports may be required. Consult your cargo box/body builder for internal structure details.

Fuel System Component Installation Hazards**⚠ DANGER****Combustible Hazard!**

An improperly installed fuel pump or fuel lines could lead to serious injury or death. The Thermo King fuel pump should be installed onto the supplied mounting bracket. The fuel pump and fuel lines should be installed a safe distance away from the extreme heat generated by the vehicle's Diesel Particulate Filter (DPF) or exhaust system components on the truck.

⚠ DANGER**Fire Hazard!**

Do not route fuel lines with battery cables or electrical wires, as this could cause a fire.

⚠ DANGER**Fire Hazard!**

Leaking fuel lines could cause a fire resulting in death or serious injury. All fuel line fittings must be tight and leak free.

⚠ DANGER**Hazard of Explosion!**

Diesel fuel vapors are potentially explosive. Use extreme caution when drilling holes in or around diesel fuel tanks. Sparks from an electric drill or drill bit could cause an explosion. Drain all diesel fuel from the tank and use nitrogen or an inert gas to purge the diesel vapors from the tank prior to drilling into or around the fuel tank. Keep the diesel fuel tank filled with inert gas while drilling.

⚠ DANGER**Hazard of Explosion!**

An improperly installed fuel tank could lead to serious injury or death. Consult your truck's chassis manufacturer for specific details on proper fuel tank installation and recommendations.



Battery Installation and Cable Routing Hazards

⚠ WARNING

Hazard of Explosion!

An improperly installed battery could result in a fire, explosion, or injury. A Thermo King approved battery must be installed and properly secured to the battery tray.

⚠ WARNING

Hazard of Explosion!

Improperly installed battery cables could result in a fire, explosion, or injury. Battery cables must be installed, routed, and secured properly to prevent them from rubbing, chaffing, or making contact with hot, sharp, or rotating components.

⚠ WARNING

Fire Hazard!

Do not attach fuel lines to battery cables or electrical harnesses. This has the potential to cause a fire and could cause serious injury or death.

⚠ WARNING

Hazard of Explosion!

Always cover battery terminals to prevent them from making contact with metal components during battery installation. Battery terminals grounding against metal could cause the battery to explode.

⚠ CAUTION

Hazardous Service Procedures!

Set all unit electrical controls to the OFF position before connecting battery cables to the battery to prevent unit from starting unexpectedly and causing personal injury.

SPECTRUM Selection Guide

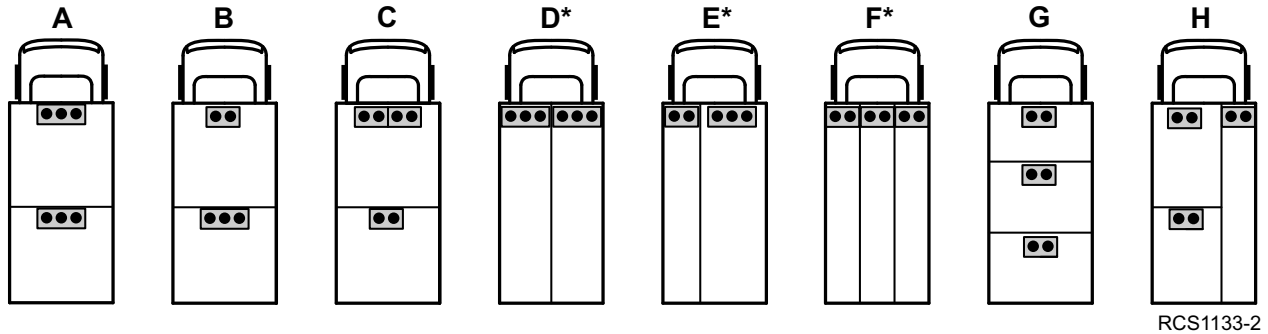

INSTALLATION COFIGURATIONS								
Fig.	Zone 1	Zone 2	Zone 3	2 Zone Install Kit 801277 REQUIRED	3 Zone Install Kit 801280 REQUIRED	S-2 + S-2 Jumper Kit 800372 REQUIRED	2 Zone Tubing Kit 15m (50ft) 720201 OPTION	Transverse Drain Kit 880041 OPTION
A	S-3	S-3	—	801277 x 1	—	—	720201 x 1	880041 x 2
B	S-2	S-3	—	801277 x 1	—	—	720201 x 1	880041 x 2
C	S-2 + S-2	S-2	—	801277 x 1	—	800372 x 1	720201 x 1	880041 x 3
D*	S-3	S-3	—	801277 x 1	—	—	—	880041 x 2
E*	S-3	S-2	—	801277 x 1	—	—	—	880041 x 2
F*	S-2	S-2	S-2	—	801280 x 1	—	—	880041 x 3
G	S-2	S-2	S-2	—	801280 x 1	—	720201 x 1	880041 x 3
H	S-2	S-2	S-2	—	801280 x 1	—	720201 x 1	880041 x 3

*Configuration will need at least one tube kit if evaporators are mounted in the back of the zone.

Important: T-1090 SPECTRUM units should not be configured with more than six (6) total evaporator fans. Emission control software will restrict capacity performance if unit is configured with more than six (6) fans.

NOTES:

1. S-2 evaporators (902673) include mounting hardware kit (800628).
2. S-3 evaporators (902674) include mounting hardware kit (800628).
3. Two Zone installation require one installation kit (801277).
4. Three Zone installation require one installation kit (801280).
5. Transverse drain kit (880041) is needed to drain on one side toward the front or back of truck.
6. Tubing kit (720201) will be supplied per customer request only.
7. Quantities specified are for entire truck.
8. Evaporators can be placed at the back of each zone, however this may require different refrigerant and drain tube routing.

Returnable Steel Crate Information

Overview

Important: Safety precautions must be followed. Refer to **Unit Installation Hazards** in the **Safety Precautions** section of this manual before proceeding.

The information provided in this section must be followed when handling self-powered truck units in steel returnable crates:

- Returnable steel crates “nest” for stacking by utilizing an interlocking design. This design utilizes four “pins” located on top of the support members that fit into pockets on the bottom of another support member. When stacking crated self-powered truck units, be sure the pins are fully seated into the pockets.
- Use only the provided forklift pockets to lift steel crated self-powered truck units.
- When storing steel crated self-powered truck units, do not stack over five (5) high.

Important: Your forklift must be rated for the combined weight of the self-powered truck unit and the steel crate. See table below.

UNIT MODEL	UNIT WEIGHT (approximate)	STEEL CRATE WEIGHT	TOTAL WEIGHT OF UNIT WITH STEEL CRATE
T-590 Model 30 T-590 SmartPower Model 50	413 kg (910 lbs.) 441 kg (973 lbs.)	236 kg (520 lbs.)	649 kg (1430 lbs.) 677 kg (1493 lbs.)
T-690 Model 30 T-690 Model 30 MAX T-690 SmartPower Model 50 T-690 SmartPower Model 50 MAX	413 kg (910 lbs.) 429 kg (947 lbs.) 441 kg (973 lbs.) 458 kg (1010 lbs.)		649 kg (1430 lbs.) 665 kg (1467 lbs.) 677 kg (1493 lbs.) 694 kg (1530 lbs.)
T-890 Model 30 T-890 Model 30 MAX T-890 SmartPower Model 50 T-890 SmartPower Model 50 MAX	437 kg (990 lbs.) 466 kg (1027 lbs.) 462 kg (1099 lbs.) 515 kg (1136 lbs.)		685 kg (1510 lbs.) 702 kg (1547 lbs.) 734 kg (1619 lbs.) 751 kg (1656 lbs.)
T-1090 Model 30 T-1090 Model 30 MAX T-1090 SmartPower Model 50 T-1090 SmartPower Model 50 MAX	453 kg (1014 lbs.) 477 kg (1051 lbs.) 502 kg (1123 lbs.) 526 kg (1160 lbs.)		696 kg (1534 lbs.) 713 kg (1571 lbs.) 745 kg (1643 lbs.) 762 kg (1680 lbs.)
T-1090 SPECTRUM Model 30 T-1090 SPECTRUM SmartPower Model 50	400 kg (883 lbs.) 450 kg (992 lbs.)		636 kg (1403 lbs.) 686 kg (1512 lbs.)

Crate Breakdown Procedures

Follow these steps after unit has been removed from crate:

1. Remove mounting posts by rotating twist-lock handle to **UP** position, then pulling straight up.
 - a. Slide each post into retaining channels located on crate base.
 - b. Rotate twist-lock handle to secure posts to channels.

Note: Mounting posts *must* be secured to retaining channels for shipment.

2. Fold down front and rear supports by sliding locking rings **UP** until they rest on tab, then fold each support member down flat.
3. Crate is now ready to return.

Figure 1. Returnable Crate Components Shown

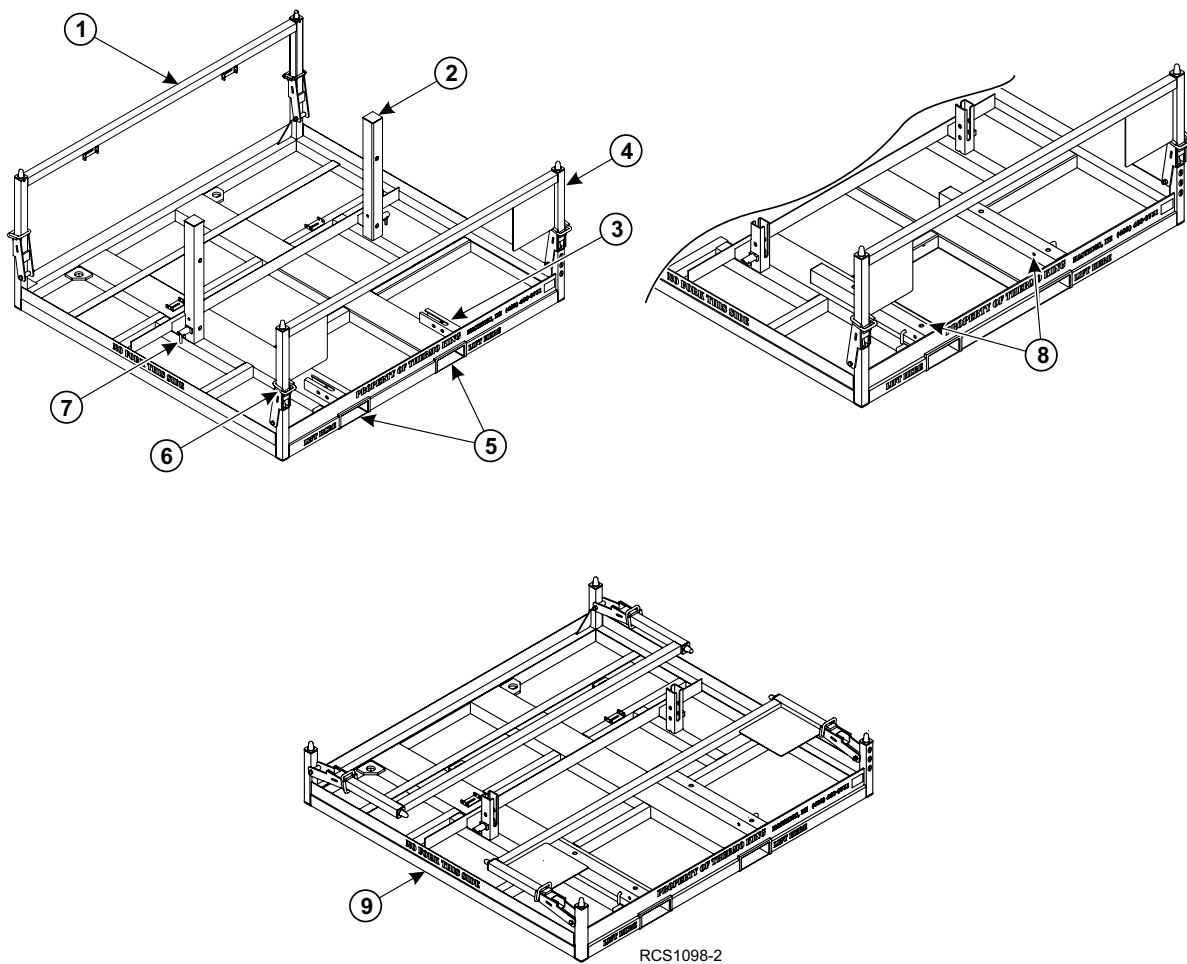

1.	Rear Support Member	6.	Locking Rings (X4)
2.	Mounting Posts (X2)	7.	Twist Locks (X2)
3.	Retaining Channels (X2)	8.	Mounting Post Secured to Retaining Channels
4.	Front Support Member	9.	Crate Shown Ready to Return
5.	Forklift Pockets (X2)		

Important Storing and Return Shipping Information

Empty crates can be stacked up to twelve (12) high for storage.

Important: Be sure your forklift can safely reach these heights while lifting a 236 kg (520 lb.) crate.

When returning crates, they should be stacked no more than eight (8) high.

Important: Eight (8) crates @ 236 kg (520 lbs.) = 1,887 kg (4,160 lbs): Be sure your forklift is rated for this amount of weight.

Figure 2. Crates Shown Stacked for Return – Maximum Eight (8) High

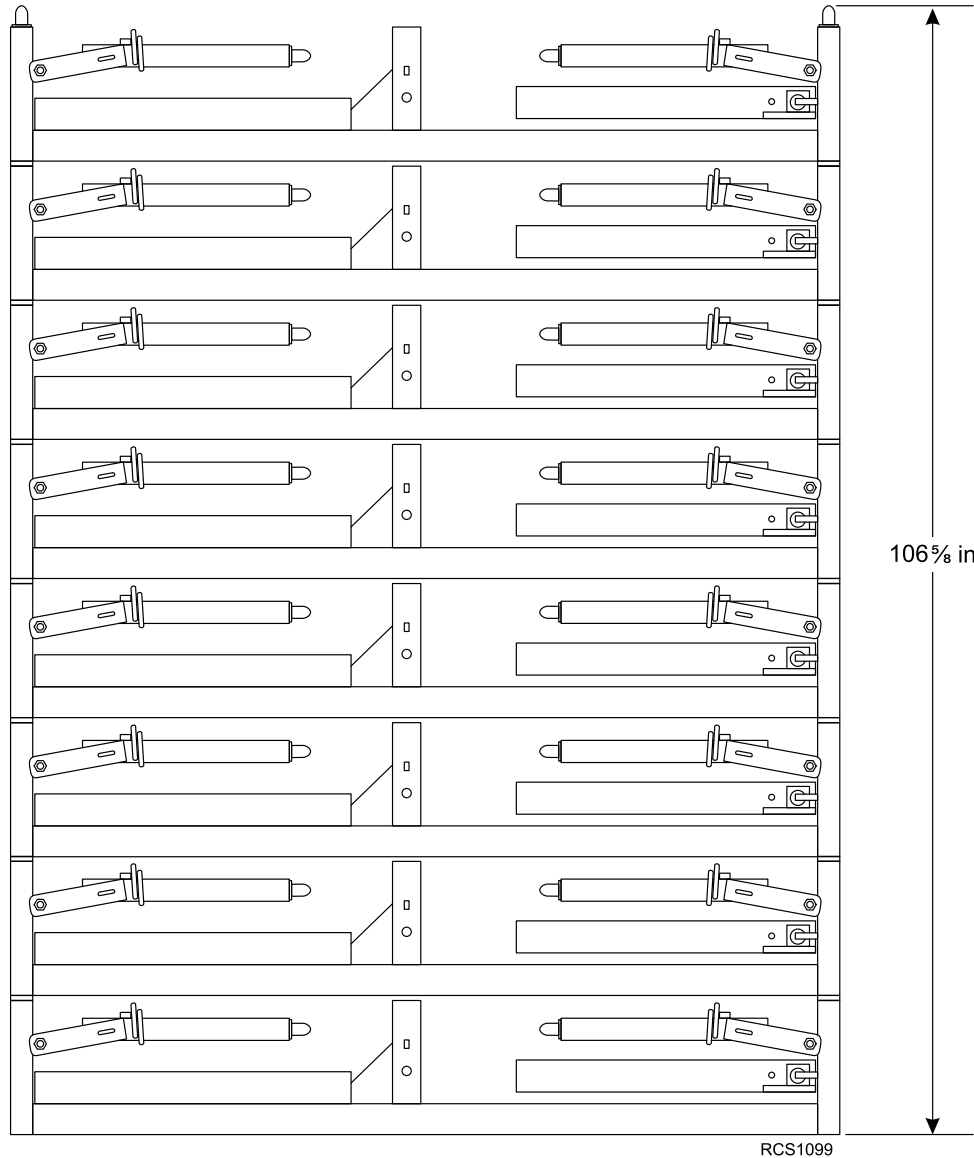

Dimensions

Unit Dimensions and Weights

Figure 3. T-1090 SPECTRUM

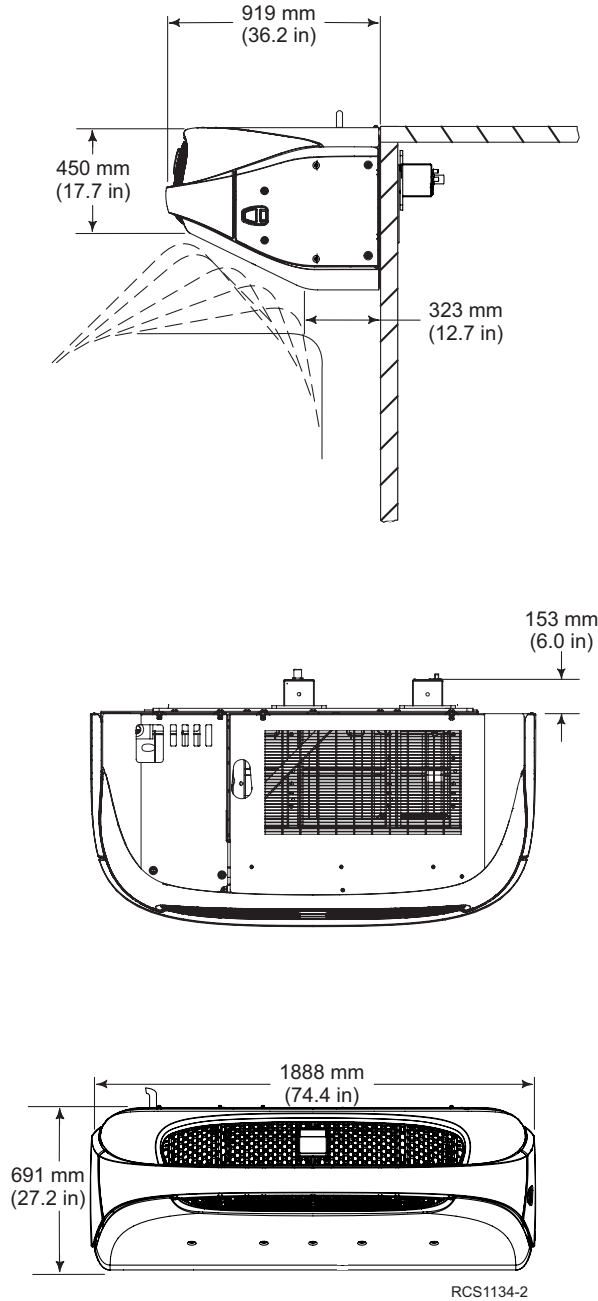

Note: Top of unit to be mounted flush with top of cargo box when possible.

UNIT	MODEL 30	MODEL 50 (SmartPower)
T-1090 SPECTRUM	883 lbs. (400 kg)	992 lbs. (450 kg)

Unit Service Area Dimensions

Figure 4. T-890, T-1090 and T-1090 SPECTRUM Units

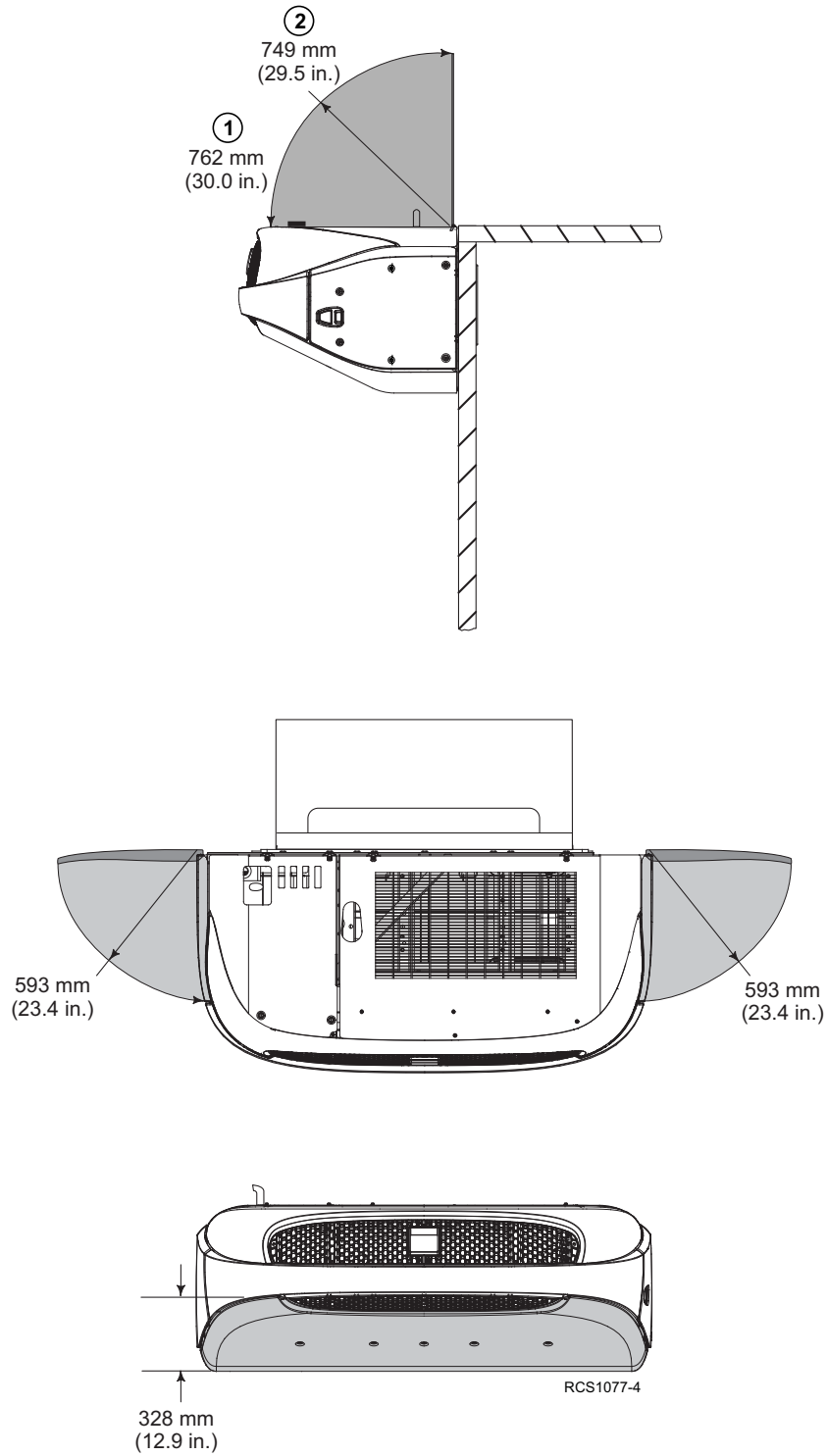

1.	Service Area Dimensions with Top Screen (Option)	2.	Service Area Dimensions with Top Cover (Option)
----	--	----	---

Truck Body Opening Dimensions

Figure 5. T-1090 SPECTRUM Only – Front View of Truck Body Opening Dimensions From Outside of Truck

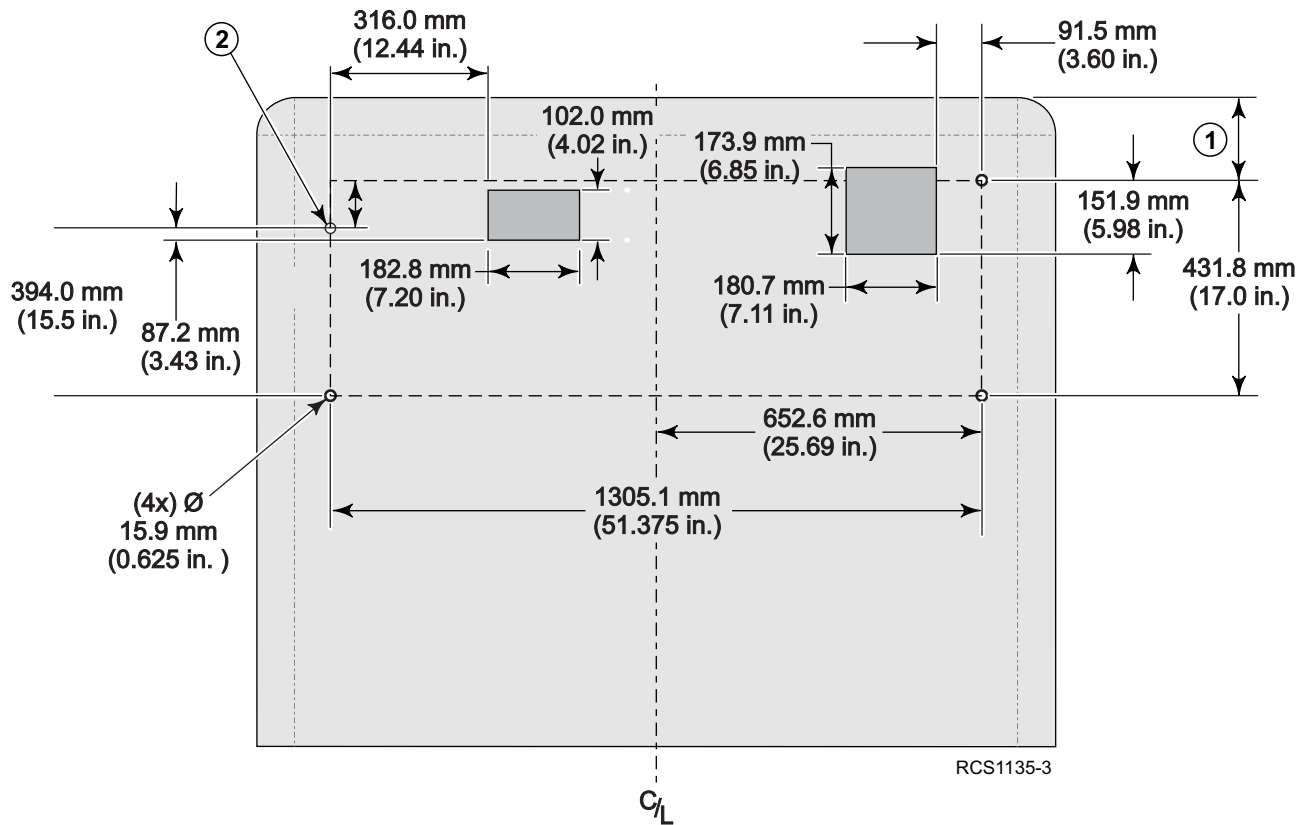

1.	Top of unit to be mounted flush with top of cargo box when possible.
2.	Note this upper curbside mounting hole is 38 mm (1.5 in.) lower than previous T-Series units.

Evaporator Dimensions and Weights

Figure 6. S-2 Dimensions and Weight

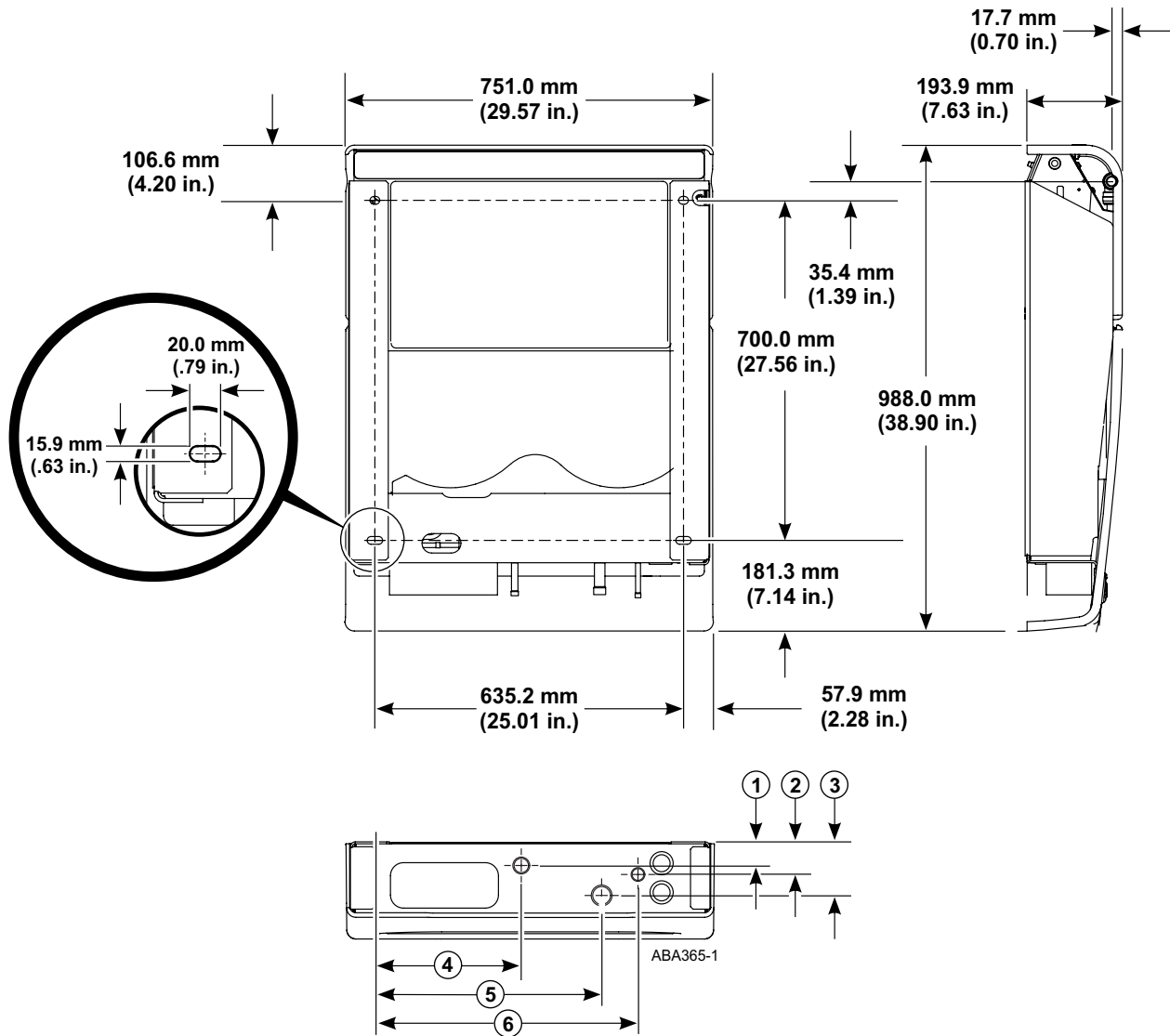

1	48.9 mm (1.93 in.)
2	67.4 mm (2.65 in.)
3	111.1 mm (4.37 in.)
4	298.7 mm (11.76 in.)
5	465.3 mm (18.32 in.)
6	541.6 mm (21.32 in.)

43kg (95 lbs.)

Figure 7. S-2 + S-2 Dimensions and Weights

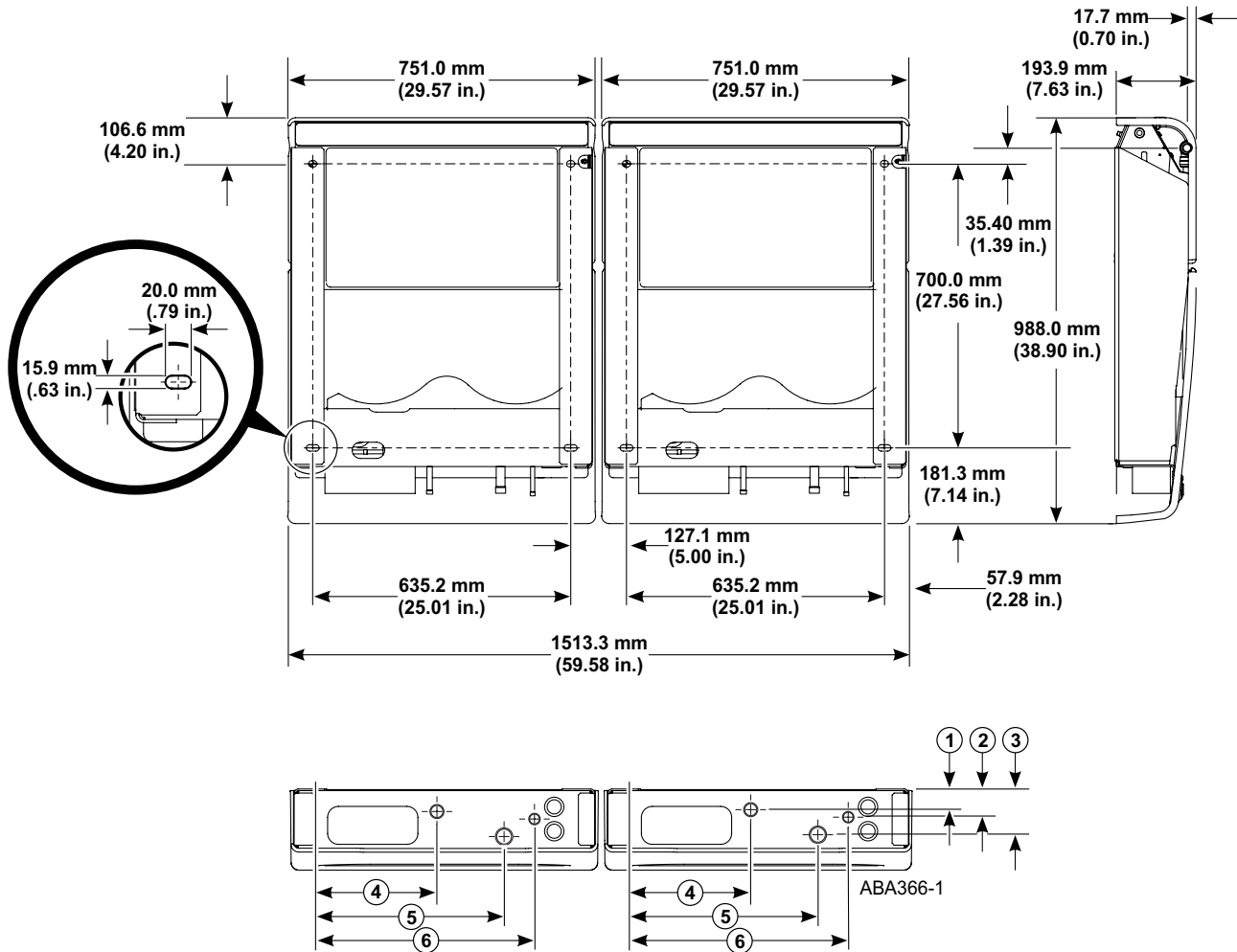

1	48.9 mm (1.93 in.)
2	67.4 mm (2.65 in.)
3	111.1 mm (4.37 in.)
4	298.7 mm (11.76 in.)
5	465.3 mm (18.32 in.)
6	541.6 mm (21.32 in.)

43 kg (95 lbs.) X 2

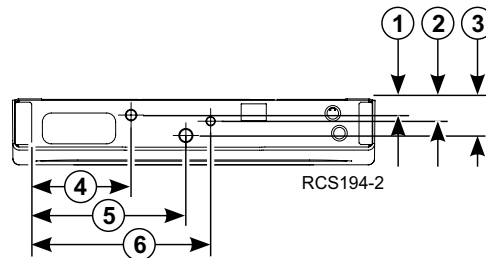
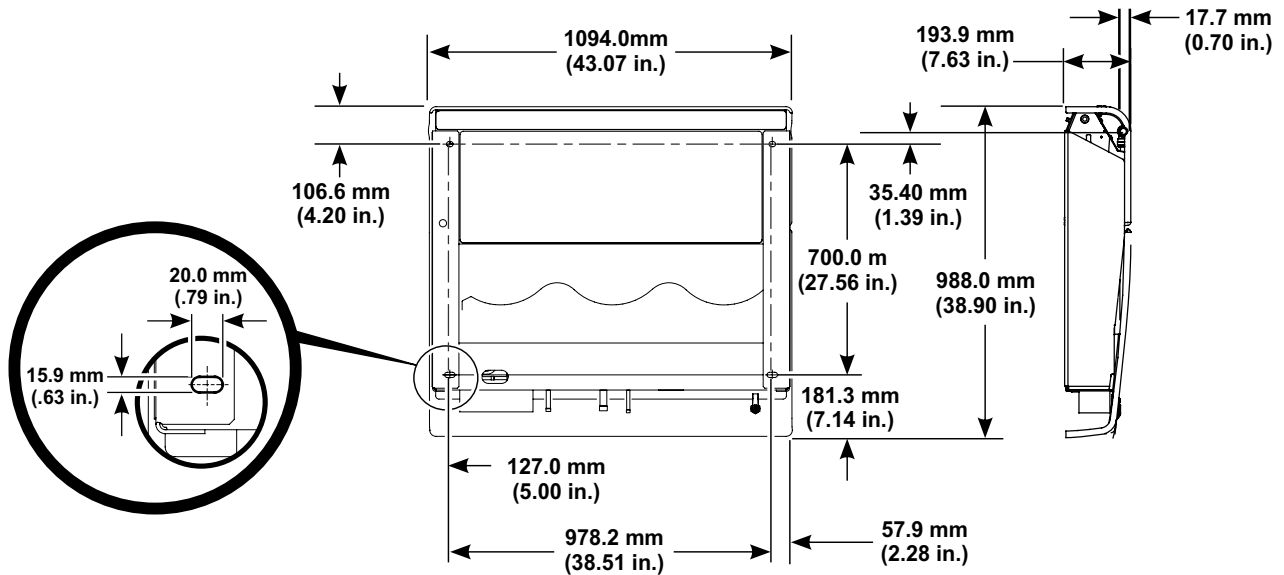
Figure 8. S-3 Dimensions and Weight

1	48.9 mm (1.93 in.)
2	67.4 mm (2.65 in.)
3	111.1 mm (4.37 in.)
4	298.6 mm (11.76 in.)
5	465.4 mm (18.32 in.)
6	541.6 mm (21.32 in.)

52 kg (115 lbs.)

Figure 9. S-3 + S-3 Dimensions and Weights

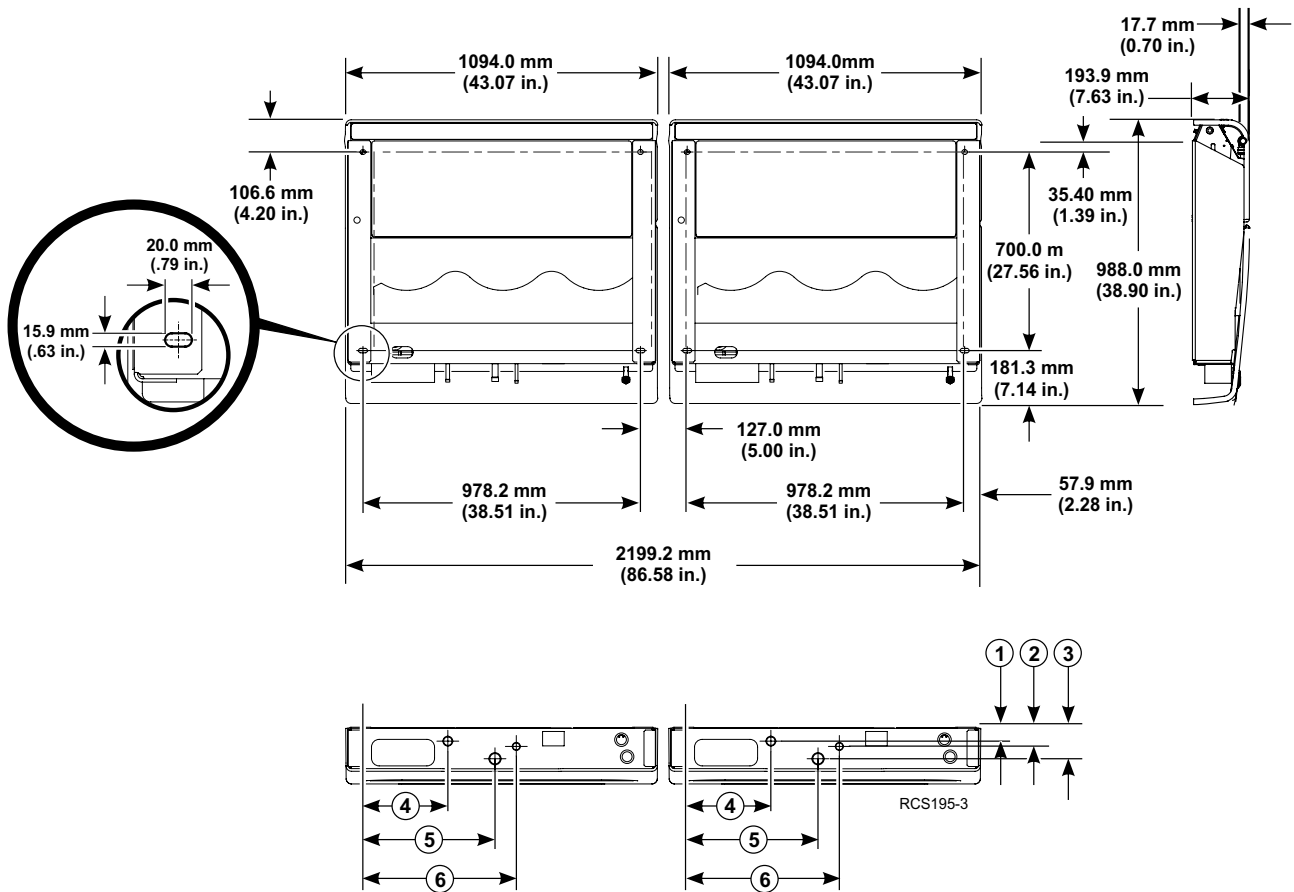

1	48.9 mm (1.93 in.)
2	67.4 mm (2.65 in.)
3	111.1 mm (4.37 in.)
4	298.6 mm (11.76 in.)
5	465.4 mm (18.32 in.)
6	541.6 mm (21.32 in.)

52 kg (115 lbs.) X 2

Unit Lifting Bar Dimensions

Figure 10. Lifting Bar Dimensions – Page 1

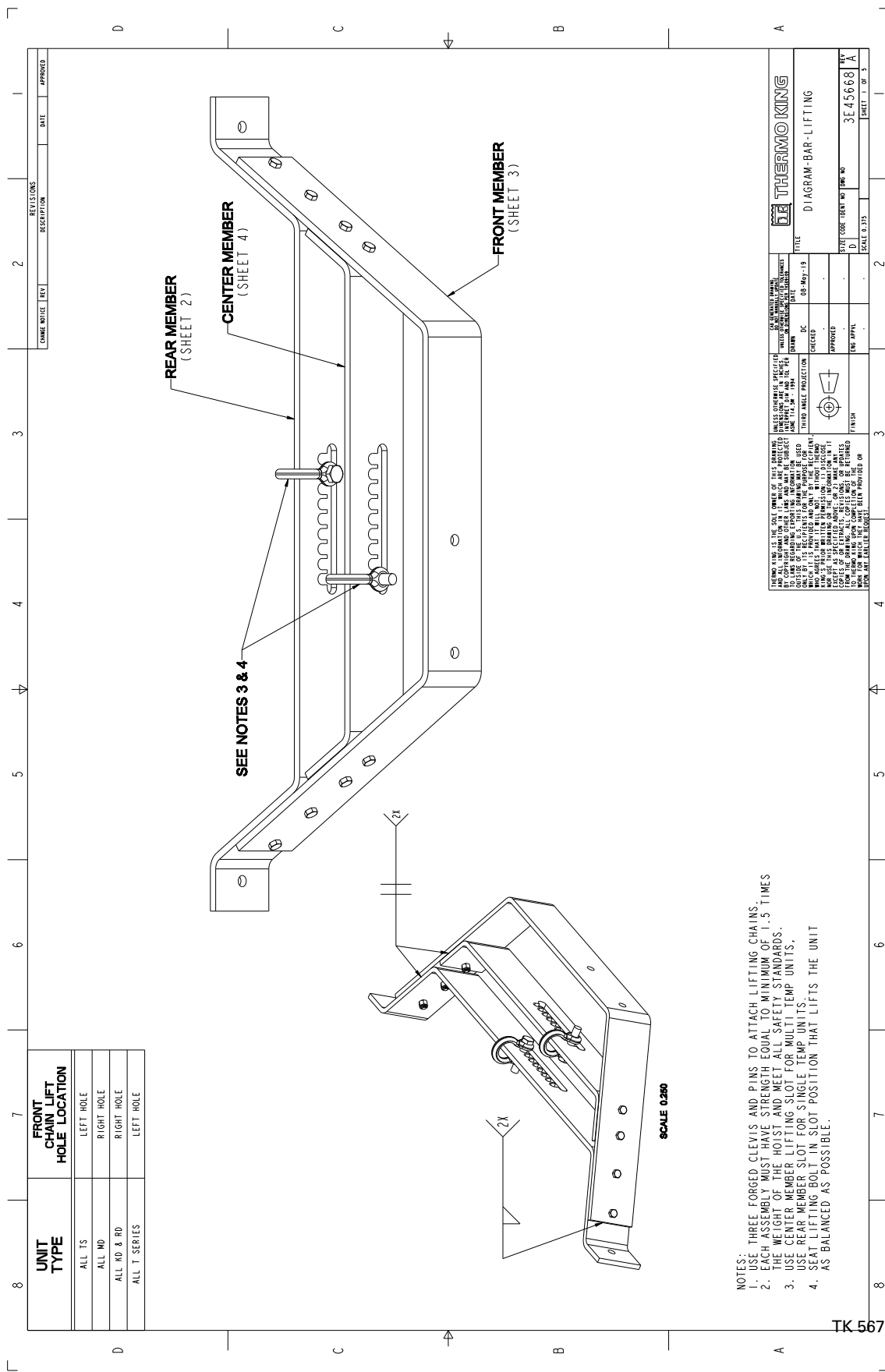
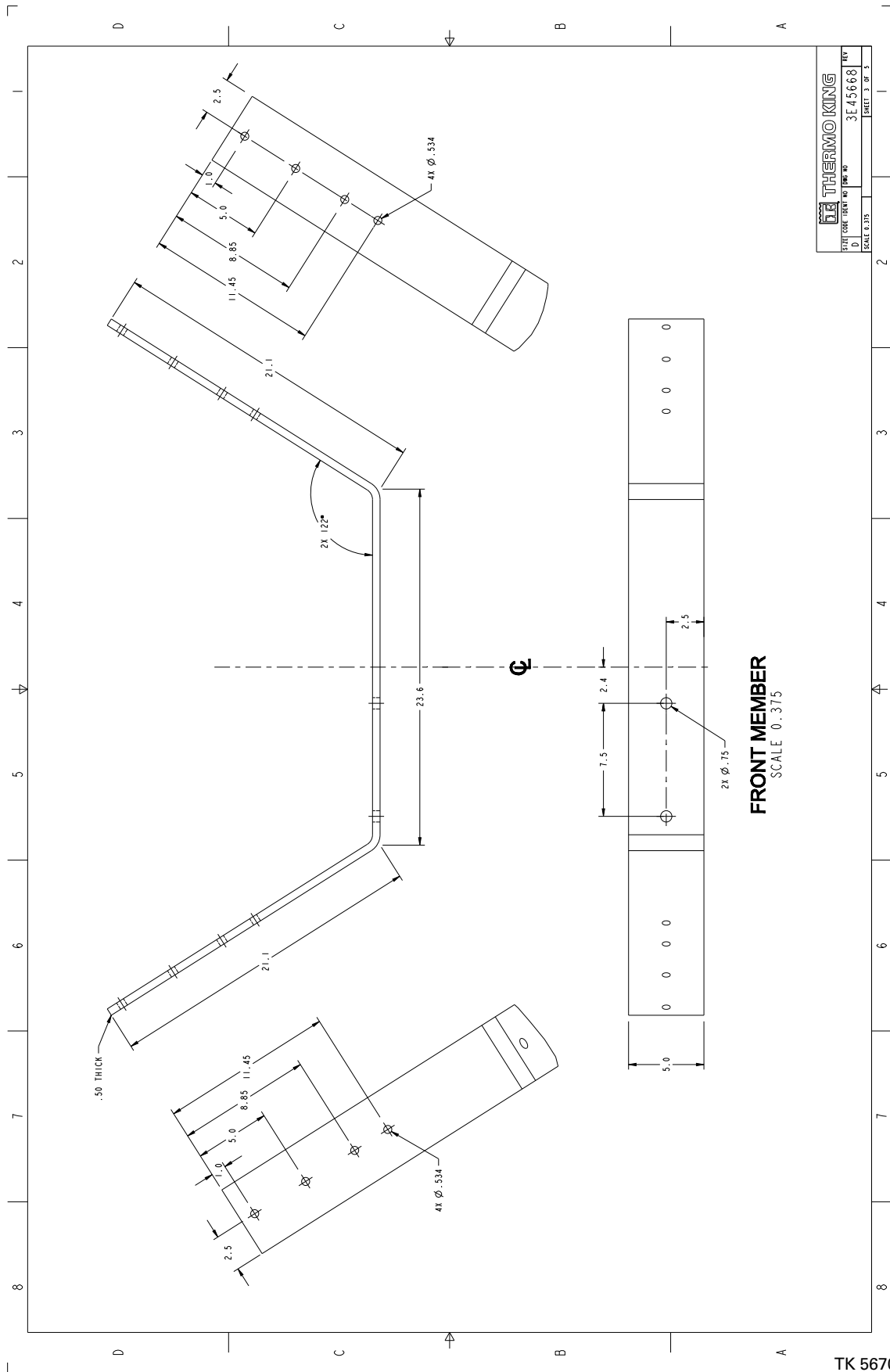
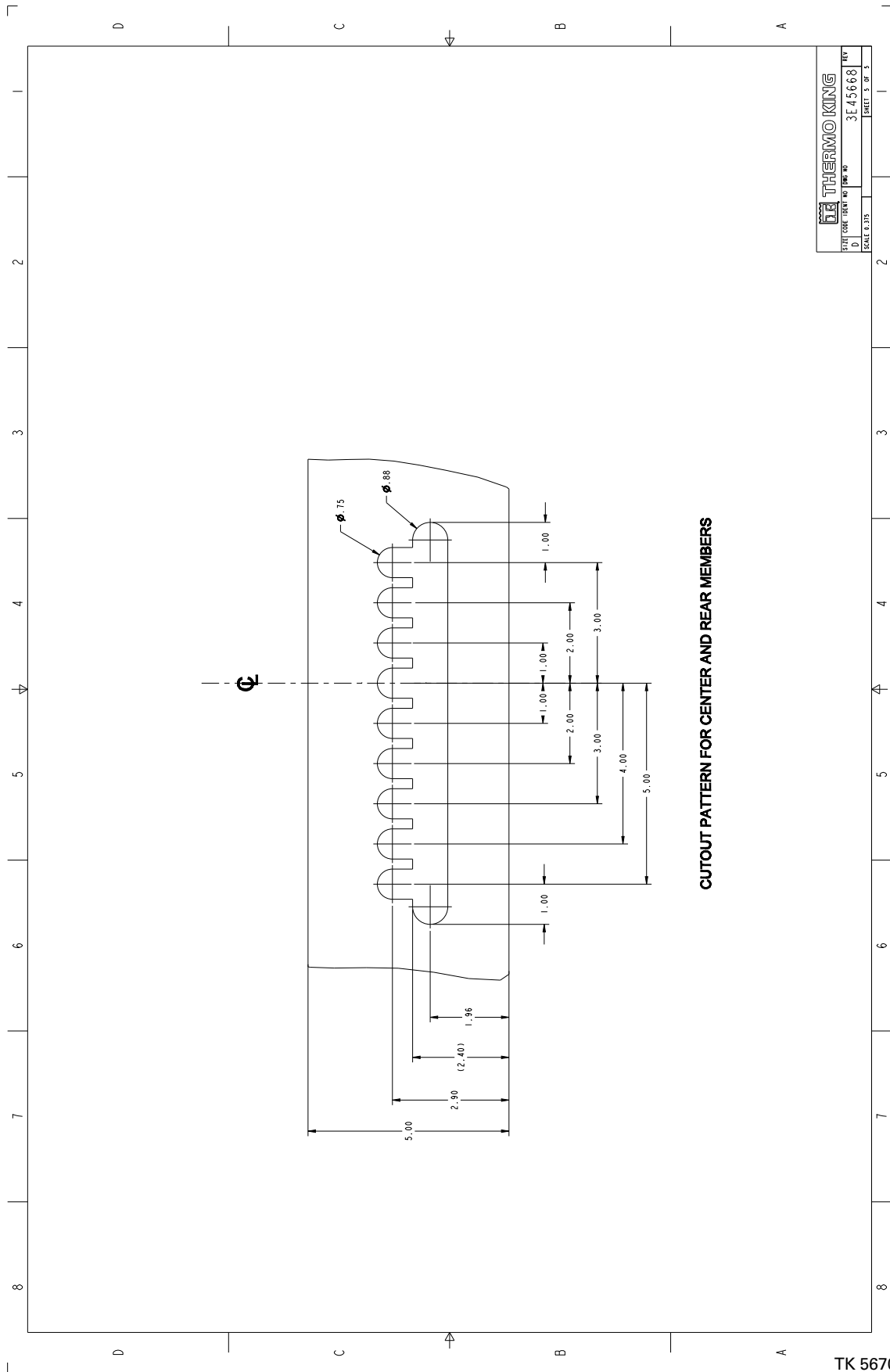

Figure 12. Lifting Bar Dimensions – Page 3

THERMO KING	
STATE	3E45668
DATE	REV
D	3E45668
SCALE 0.375	
SHEET 3 OF 5	

Figure 14. Lifting Bar Dimensions – Page 5



THERMO KING	
STATE	3E45668
DATE	REV
SCALE	3 OF 5

HMI Controller Dimensions

Figure 15. Premium and Basic HMI Controllers Shown

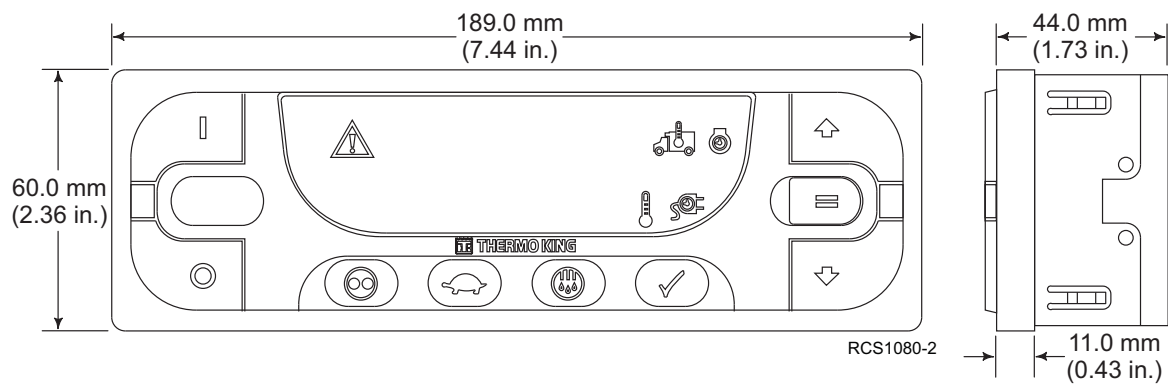
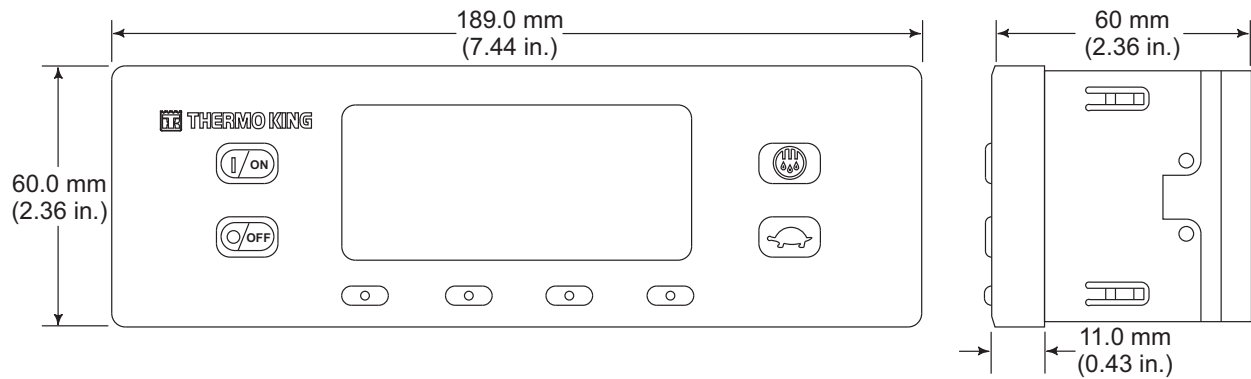

Standby Power Receptacle Dimensions (OPTION)

Figure 16. North American and International Model Receptacles Shown

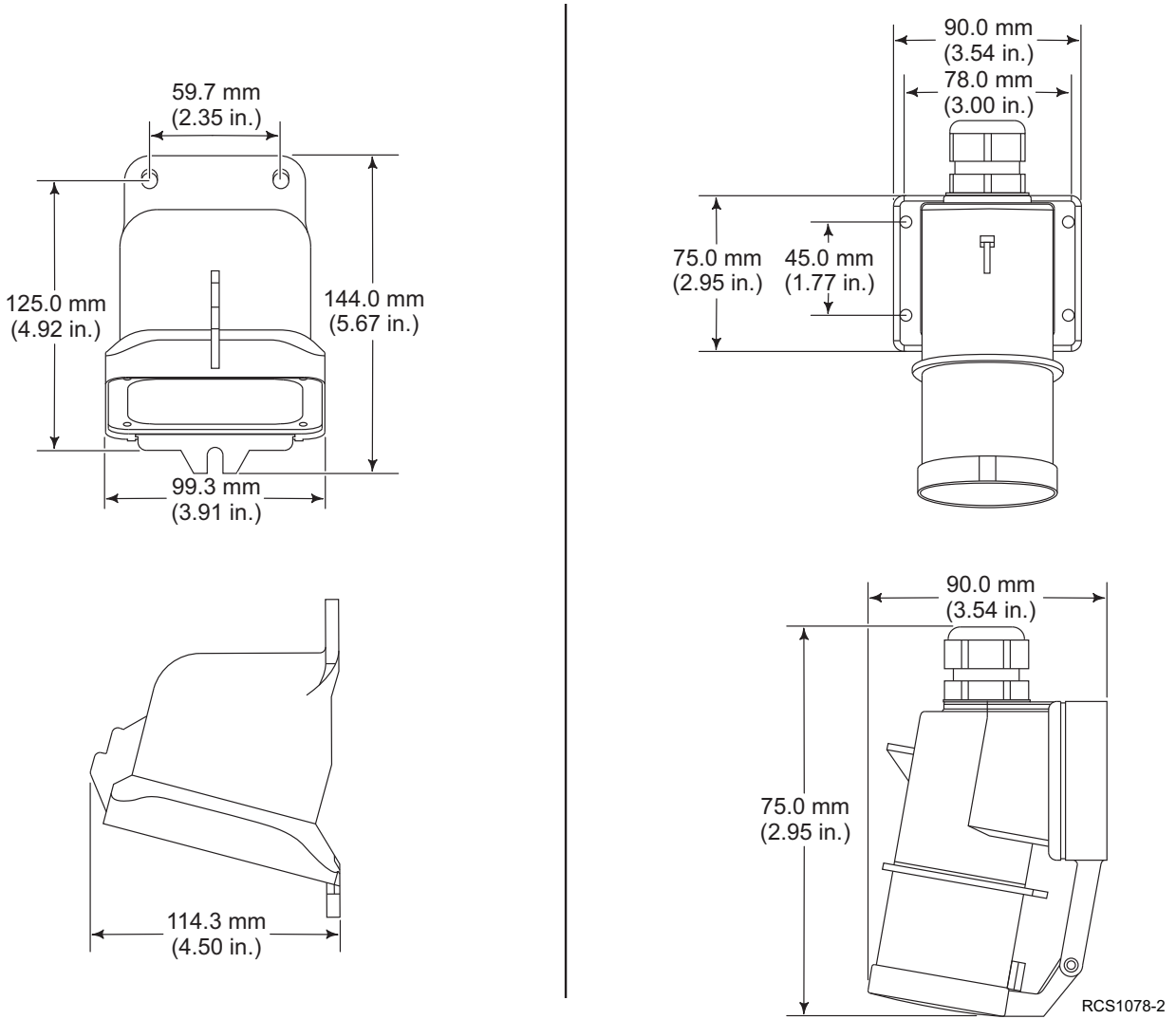

PAGE INTENTIONALLY BLANK

Required Tools

1. Safety Glasses
2. Drill
3. Drill Bits
4. Tape Measure
5. Wire Crimpers
6. Tube Benders
7. Hole Saw
8. 15% Solder and Flux (copper to copper)
9. 35% Solder and Flux (copper to brass)
10. Swage
11. Tubing Cutter
12. Refrigerant Oil
13. Torch Set
14. Mechanics Tools
15. Manifold Set
16. Evacuation Station
17. Reclaiming Station
18. Refrigerant and Scale
19. Dry Nitrogen
20. Tap and Die Set
21. Battery Charger
22. Electronic Leak Detector
23. Tubing Brushes
24. Scotch-Brite™ Pads
25. Lifting Bar (Thermo King design) with forged links, clevises and pins.
26. Work Platform (recommended)
27. Torque Wrench
28. Mechanical Lift (recommended)

Figure 17. Required Tools Shown

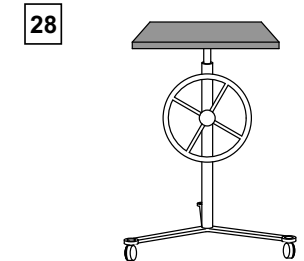
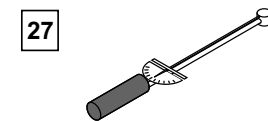
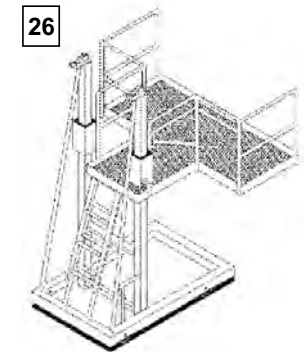
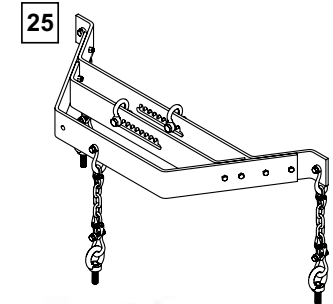
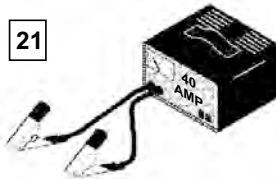
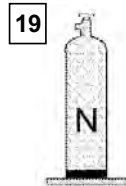
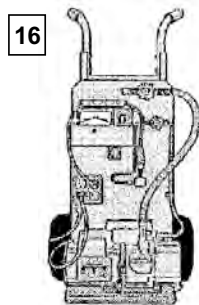
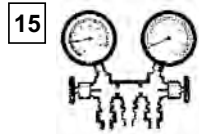
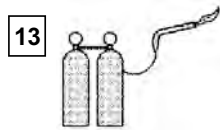
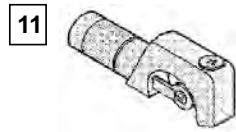
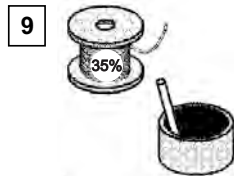
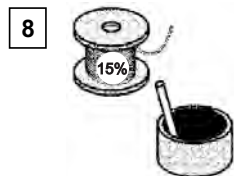
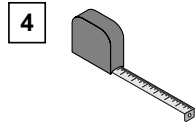
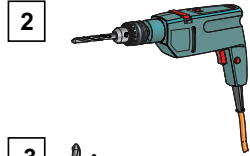

ABA580-1

Condensing Unit Installation Components

Note: The following installation components are provided to complete a standard condensing unit installation. Customer ordered options are not shown.

1. Nut-Blind
2. Screw, 1/4"–20
3. Flat Washer, 1/4"
4. Lock Washer, 1/4"
5. Fuel Fittings
6. Insulated Clamps
7. Clamp
8. Exhaust Pipe Extension
9. Check Valve
10. Terminal Lug, 3/8" 2 AWG
11. Terminal Lug, 3/8" red
12. Fuel Pump
13. Fuel Pump Mounting Bracket
14. Screw, 1/4"–20
15. Lock Nut, 1/4"-20
16. Fuel Pickup Tube Assembly
17. Clip
18. Fuse, In-line 60 Amp
19. Flat Washer #10
20. Screw, #10
21. Screw, #8
22. Washer, #8
23. DIN Bracket
24. Washer, 2" OD
25. Premium HMI Harness Adapter
26. HMI In-Cab Mounting Brackets
27. Premium HMI Controller
28. Operator's Manual QR Code Nameplate
29. Warning Nameplate

Figure 18. Condensing Unit Installation Components Shown

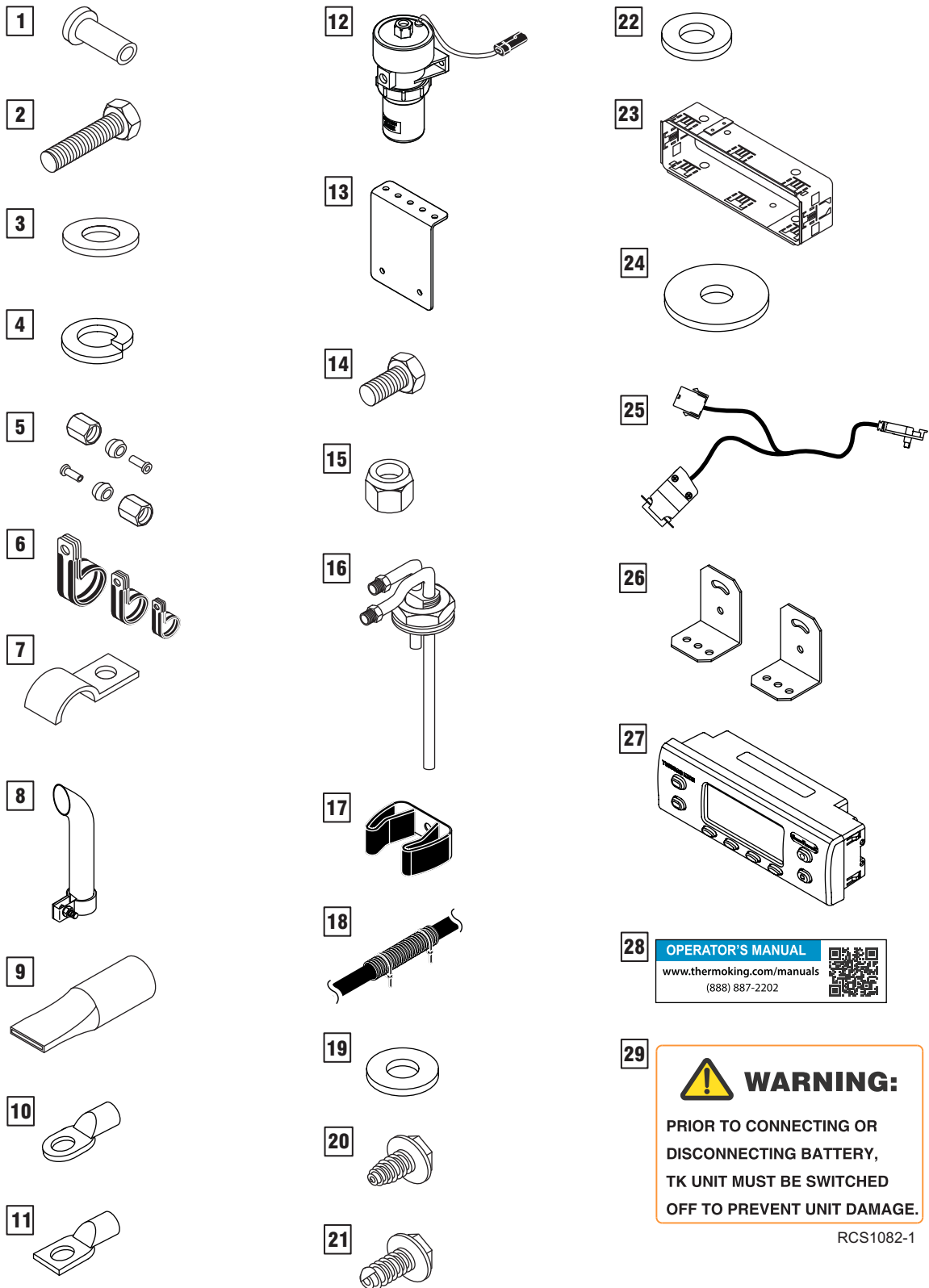

RCS1082-1

Installing Condensing Unit

Unit Mounting Bolt Requirements

NOTICE

Equipment Damage!

All mounting bolts must be the correct length for their applications and torqued to specification. Incorrect bolt lengths and improper torque specifications can damage equipment.

Unit mounting bolts are installer supplied and must meet the following requirements:

Bolt Size and Thread Pitch	1/2-13 UNC, Full Thread
Grade	SAE Grade 5 (ISO 8.8)
Finish	Zinc Dichromate, Cadmium Plated.
Length	<p>The length of each of the four mounting bolts protruding from the front wall of the cargo box is shown in the illustration.</p> <ul style="list-style-type: none"> • Three bolts are the same length. • One bolt is longer. • After unit is installed, a minimum of 2 thread pitches must extend beyond the surface of the nut.
Torque Specifications	81.4 N•m (60 ft-lb.)
Important: Apply blue thread locker to all four (4) unit mounting bolts during unit installation.	

Figure 19. Confirm a minimum of 2 thread pitches extend beyond the surface of the nut.

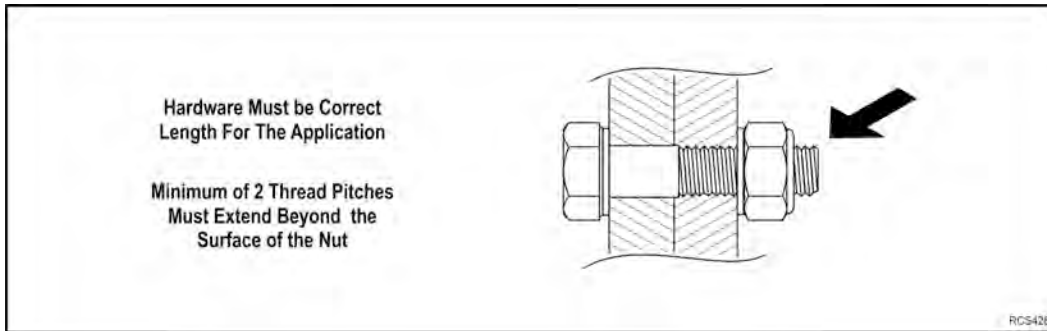

**Figure 20. Required Bolt Length Protruding From Cargo Box
(Single Temperature Shown, Multi-Temperature same)**

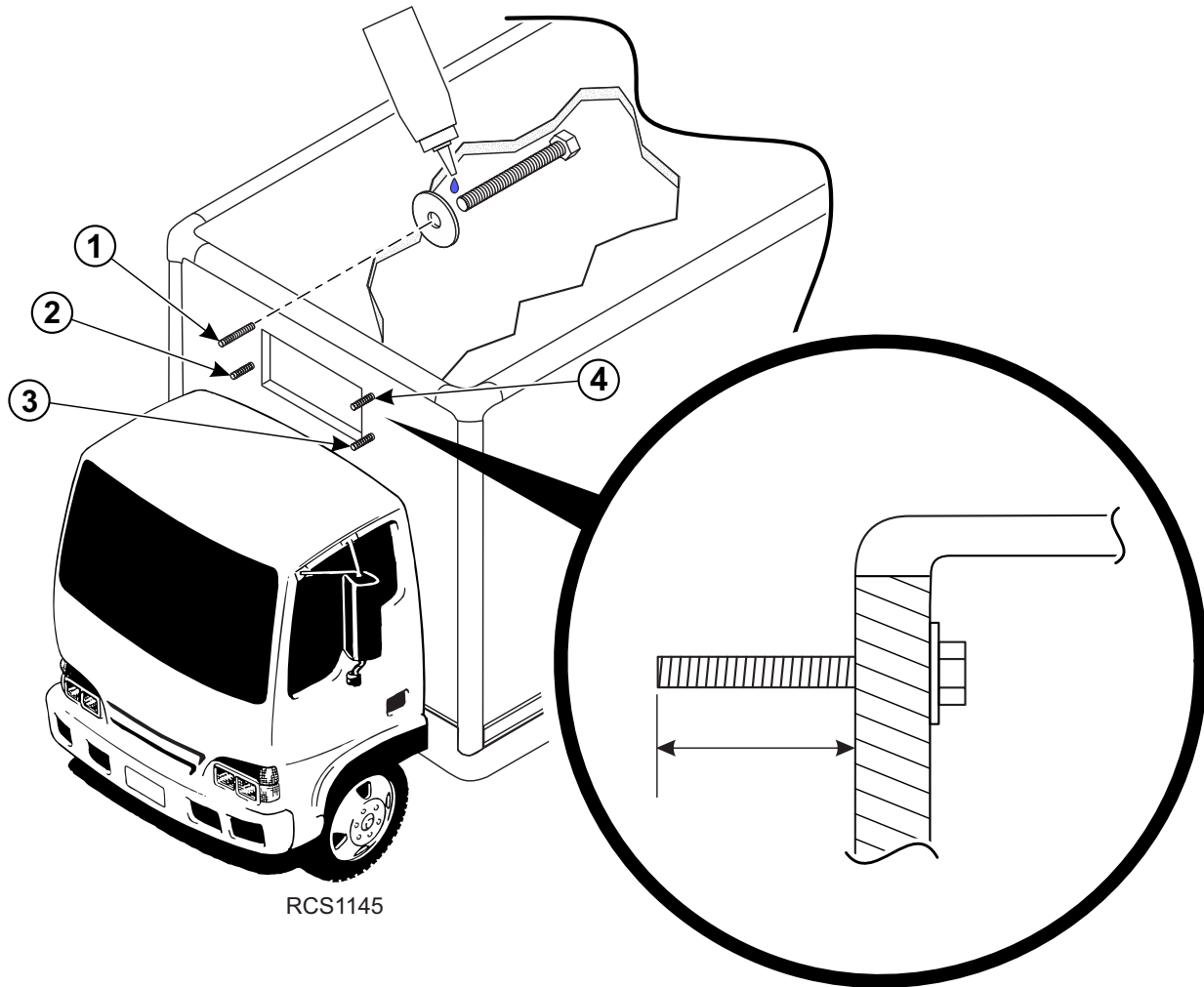

RCS1145

Required Bolt Length Protruding From Cargo Box	
1.	72 mm (2.8 in.)
2.	46 mm (1.8 in.)
3.	46 mm (1.8 in.)
4.	46 mm (1.8 in.)

Uncrating Procedures

Important: Safety precautions must be followed. Refer to **Unit Installation Hazards** located in the **Safety Precautions** section of this manual before proceeding.

Thermo King T-90 series units require a 3 point lifting bar to safely install the units. While the current lifting bar will work for installing a T-90 series unit, a new lifting bar was designed with multiple slots for improved unit balance, which are required given the wide variety of balance points for the full range of self-powered truck units. The new lifting bar can be made from the drawings provided in the Dimensions Section of this manual.

1. Remove kit box(s) shipped with unit.
2. Install M12 forged lifting eyebolts and washers (installer supplied) into the two rear frame locations and tighten securely.
3. Install M12 forged lifting eyebolt, washers and locking nut (installer supplied) into the front balance point location and tighten securely.

Important: Installer supplied lifting eyebolts must be forged steel, 12 mm, 1.75 pitch, with a minimum thread length of 20.5 mm (0.80 in.) long. Substitutions are not acceptable!

4. Use an overhead hoist and 3 point lifting bar attached to the three eyebolts and raise unit only enough to remove slack from the lifting bar chains.
5. Remove the four bolts securing the unit to the mounting posts. **DO NOT reuse these bolts to install the unit to the truck box.**
6. Unlock and remove the two mounting posts from the crate base and carefully raise unit out from crate.

The steel crate can now be broken down for storage or return. See ["Returnable Steel Crate Information," p. 12](#)

Figure 21. Uncrating Unit Shown

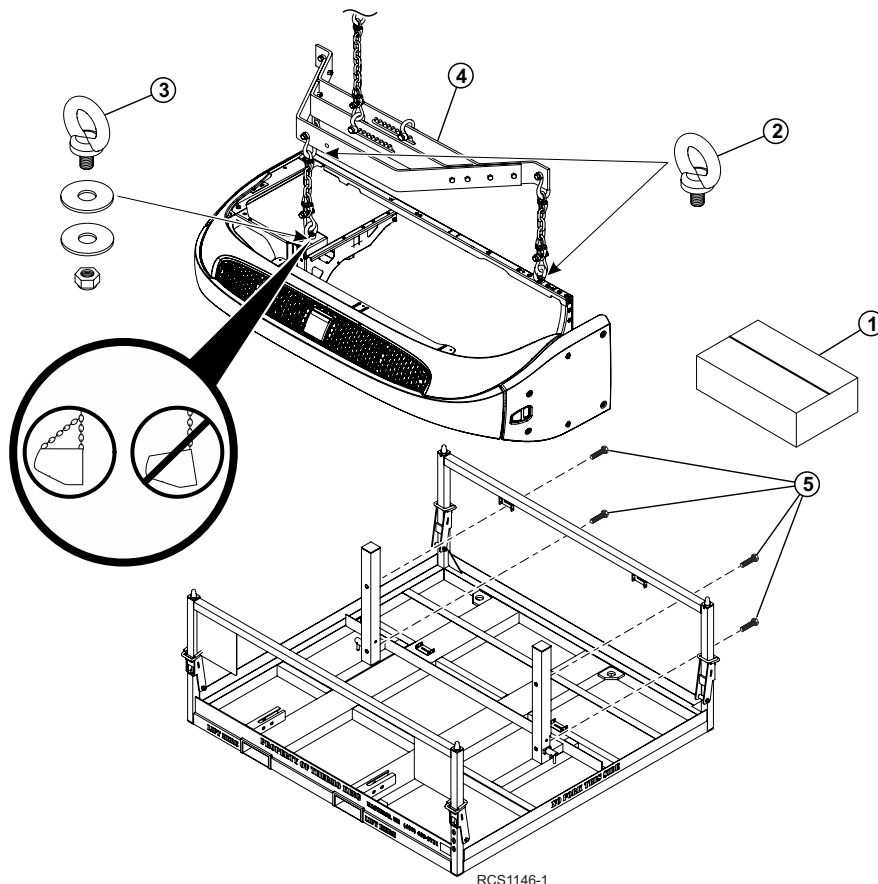

RCS1146-1

Installation Procedures

Important: Safety precautions must be followed. Refer to **Unit Installation Hazards** in the **Safety Precautions** section of this manual before proceeding.

Preferred Installation Method — Thermo King recommends the four (4) factory installed nut plates attached inside the frame along with the correct length hex head grade 5 mounting bolts (installer supplied) be used when installing the unit.

If your installation requires the nut plates be removed, see **“Alternate Installation Method”** on the next page.

Note: Do not install any compressible washers or other materials between the unit and the truck!

1. Position condensing unit into cargo box opening. Do not pull on the drain hoses or electrical wires during the installation.
2. From inside the cargo box, insert four (4) correct length mounting bolts with four (4) 2.00” OD flat washers (supplied) through the front wall of the box and into the unit’s mounting nuts.
 - a. Apply blue thread locker to all four (4) unit mounting bolts.
 - b. Tighten the mounting bolts evenly and then torque to 81.4 N•m (60 ft-lbs).
3. Disconnect and remove lifting bar and eyebolts from unit.
4. Install the exhaust extension tube pointing towards rear of truck and tighten securely.

Figure 22. Typical Installation Shown

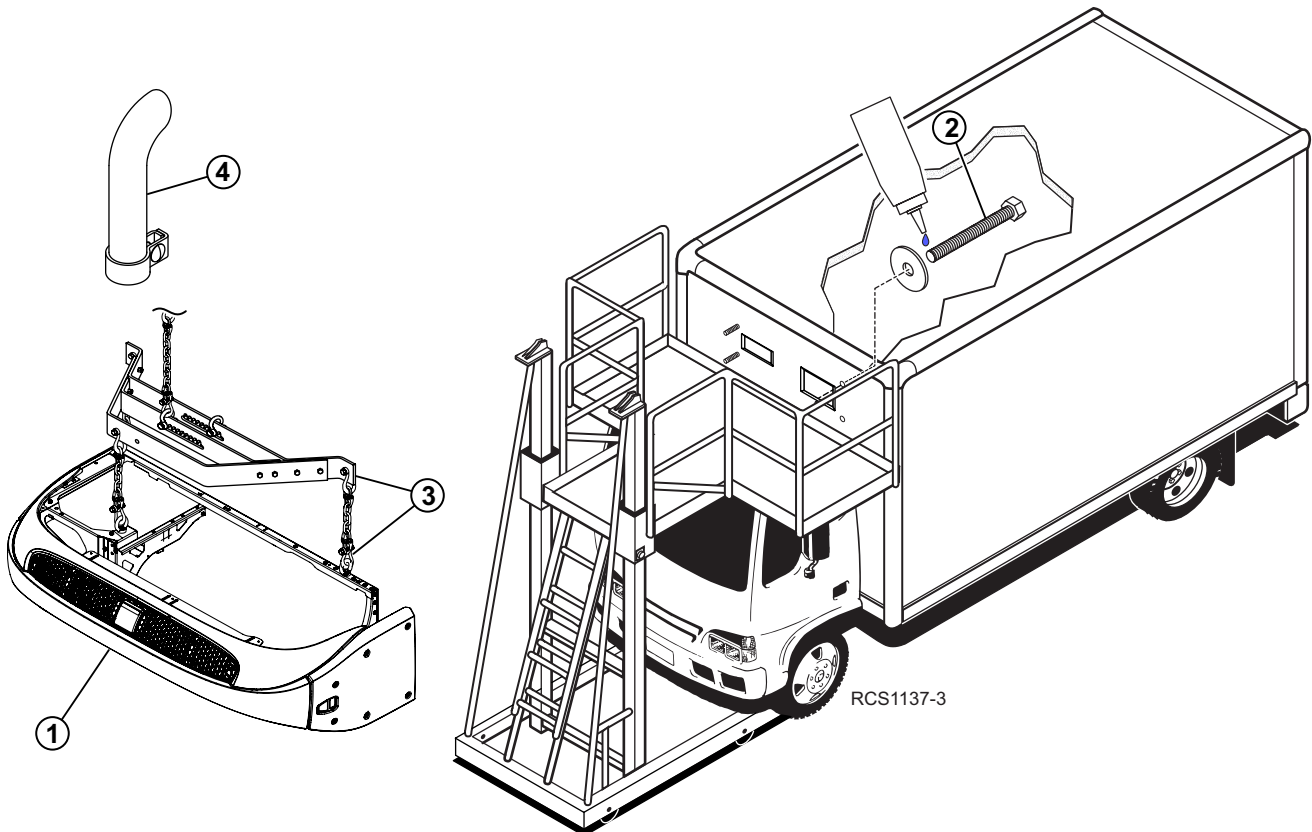

Installing Condensing Unit

Alternate Installation Method — The factory installed nut plates can be removed to accommodate a truck box equipped with mounting studs or T-bolts, provided the following procedures are followed and the additional components (installer supplied) are installed.

Important: Do not install any compressible washers or other materials between the unit and the truck!

1. Remove unit top covers (if applicable).
2. Remove unit bottom pan.
3. Remove muffler and gasket from unit. Discard gasket.
4. Remove the four (4) nut plates from the unit.
5. Confirm mounting studs or T-bolt threads protrude the require length from cargo box. See “Unit Mounting Bolt Requirements,” p. 34
6. Position unit into cargo box opening. Do not pull on the drain hoses or electrical wires during the installation.
 - a. Apply blue thread locker to all four (4) mounting studs or T-bolt threads.
 - b. Install one (1) washer (555234) and one (1) hex nut (550287) (installer supplied) onto each threaded stud or T-bolt.
 - c. Tighten the nuts evenly and then torque to 81.4 N•m (60 ft-lb).

Important: A minimum of 2 thread pitches must extend beyond the surface of the nut — more than 2 may damage internal unit components.

7. Reinstall muffler with a new gasket (331907) (installer supplied). Torque muffler hardware to 25 N•m (18.3 ft-lb).
8. Disconnect and remove lifting bar and eyebolts from unit.
9. Re-install top covers (if applicable).
10. Re-install bottom pan.
11. Install exhaust extension tube pointing towards rear of truck and tighten bolt securely.

Figure 23. Additional Components Required (Installer Supplied)

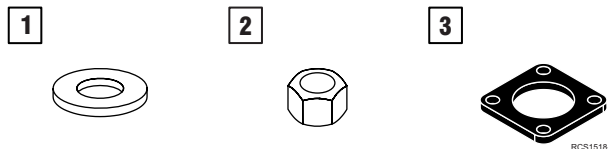

1.	Washer	555234	Qty. 4
2.	Hex Nut	550287	Qty. 4
3.	Muffler Gasket	331907	Qty. 1

Securing Oil Drain Hose

1. Secure the oil drain hose directly under the unit to the cargo box with the two (2) supplied retaining clips and self tapping screws as shown.

Note: Lower retaining clip should be positioned in a location easily accessible for servicing the unit. Your actual location will depend on the distance between the bottom of unit to top of cab, etc.

Figure 24. Oil Drain Hose Shown Secured Under Unit

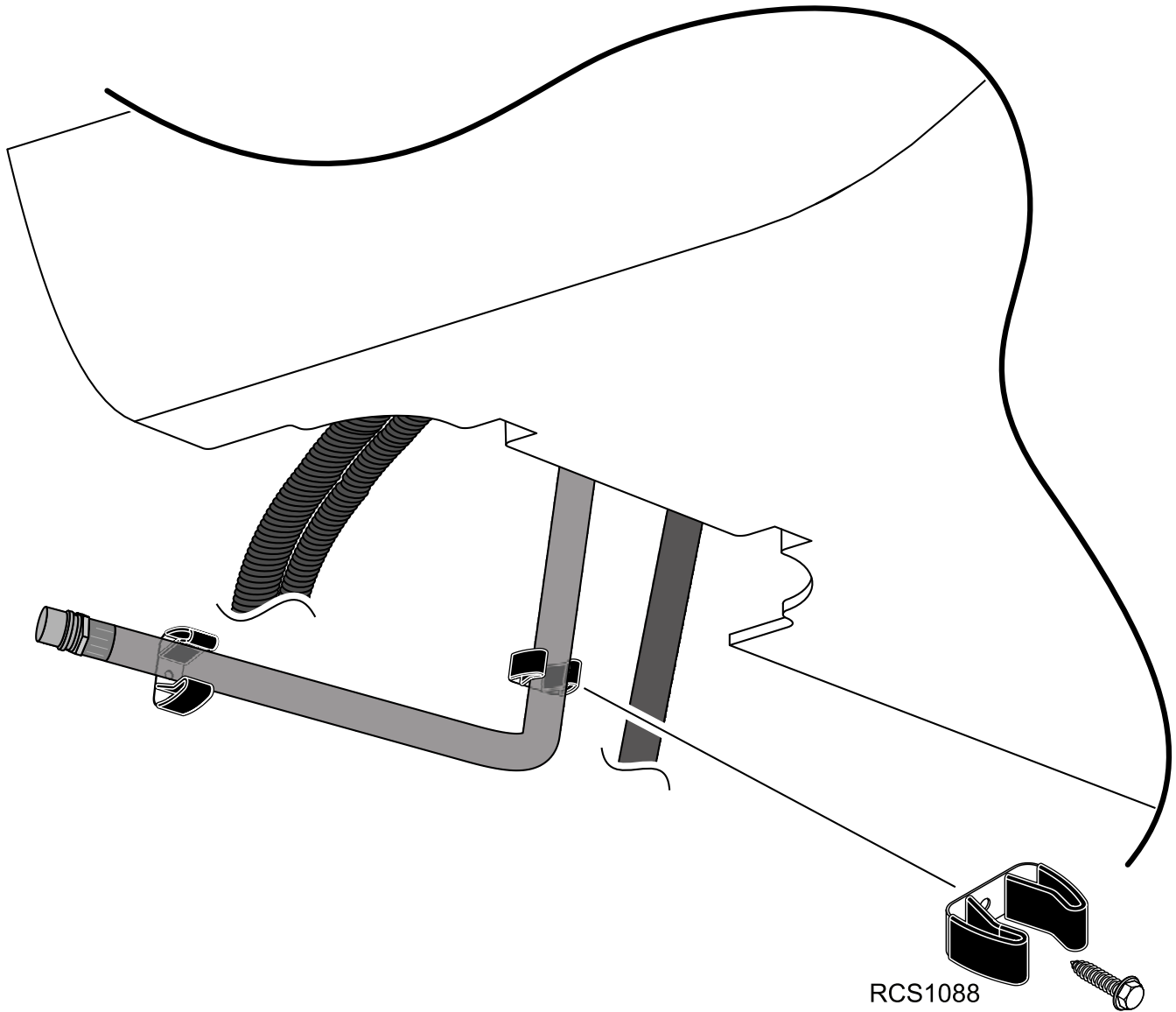

Installing USB Download Port (OPTION)

Note: Installation hardware supplied by installer.

1. Choose an appropriate location to mount the USB Download Port that provides for safe and easy access for connecting the USB Flash Drive.
2. Position the Download Port as shown and attach securely to the truck box with four TEK screws or rivets.
3. Provide a drip loop and secure harness to truck box with clamps and TEK screws or rivets.

Figure 25. Typical Installation Shown

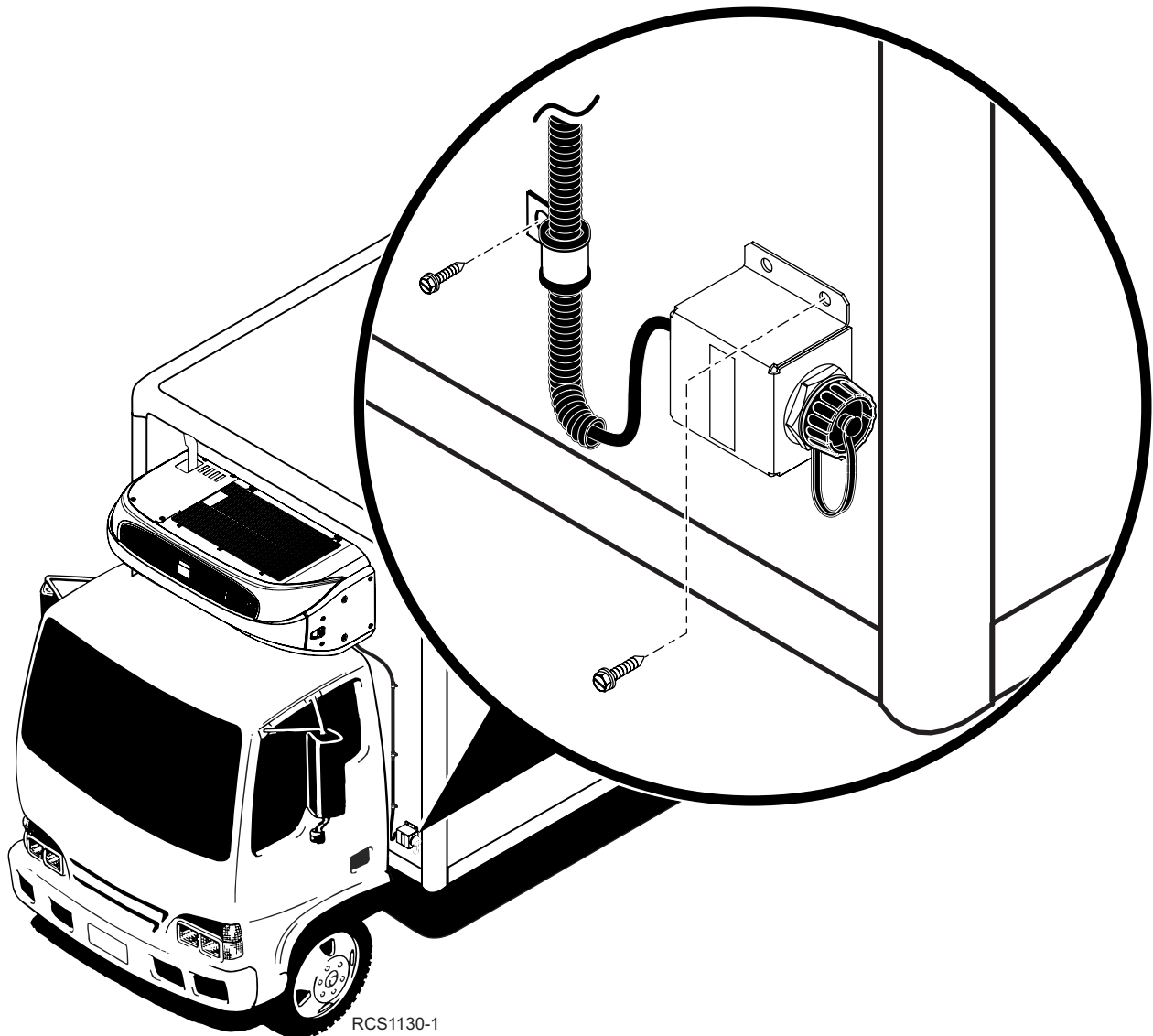

Securing Standby Power Receptacle (OPTION)

Important: Choose an appropriate location to mount the standby power receptacle that does not interfere with the safe operation of the truck while also providing easy access for connecting the power cord. The power cord and plug do not come with the unit and must be sized appropriately. Refer customer to the unit Operator's Manual for standby power requirements.

North American Models

1. Measure and drill three 13 mm (.500 in.) holes into truck box.
2. Insert rubber blind nuts (supplied) into each hole.
3. Attach receptacle with 1/4 x 20 mounting hardware (supplied) and tighten securely.
4. Secure harness to cargo box with clamps and screws (supplied).

International Models

Note: Installer to supply mounting hardware and blind nuts for International model receptacle installation.

1. Measure and drill four 9.5 mm (.375 in.) holes into truck box.
2. Insert rubber blind nuts into each hole.
3. Attach receptacle with 10-32 mounting hardware and tighten securely.
4. Secure harness to cargo box with clamps and screws (supplied).

Figure 26. Typical Installation Shown

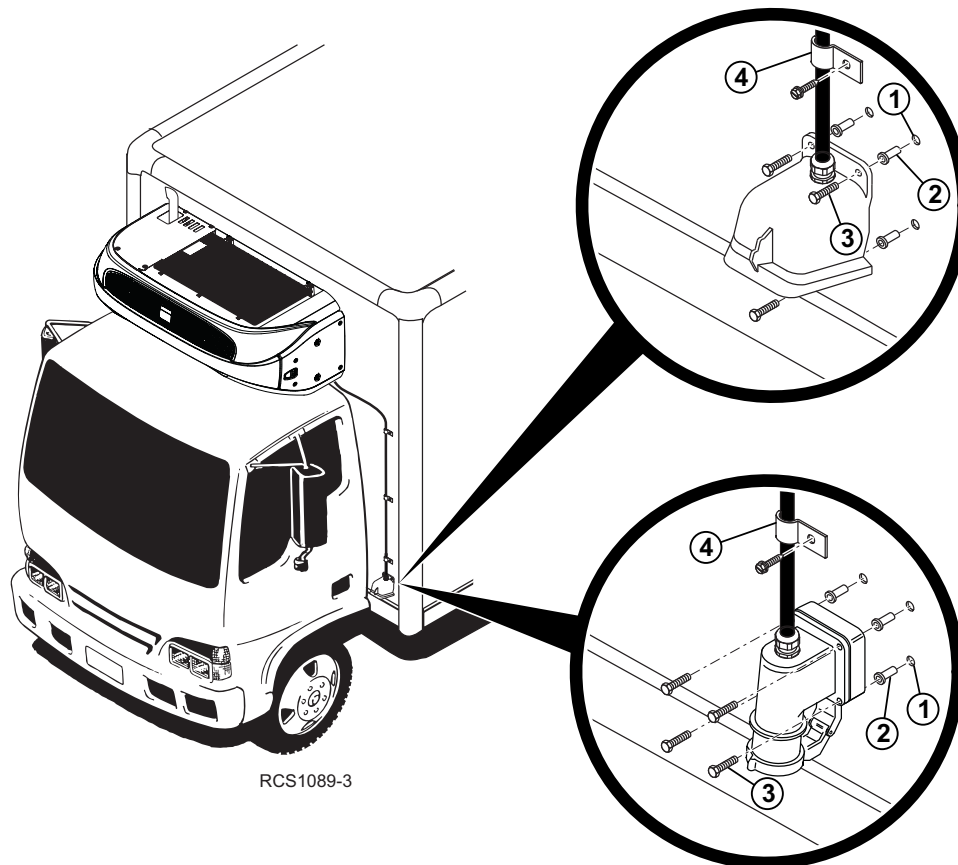

Installing HMI Controller

Important: HMI should be installed in an area inside the cab that is accessible to the driver while not interfering with the safe operation of the truck.

INSTALLATION METHODS

1. Choose installation method that best meets your needs:
 - DIN Mounting** — Supplied DIN (ISO 7736) mounting sleeve allows controller to be installed directly into driver’s panel. Make sure tabs are bent out as shown to secure sleeve into panel opening.
 - L-Brackets** — Supplied L-Brackets allow controller to be installed on top or underneath driver’s panel. Use supplied #8 screws and #8 flat washers to attach L-Brackets to controller. Installer to supply hardware to secure to driver’s panel.
2. Route controller harness from unit to inside cab.

Important: Route and secure controller harness to prevent rubbing, chafing or making contact with sharp, moving or hot components. Allow excess length harness for tilt cab applications. Supplied rubber grommets must be used when routing harness through sheet metal holes.
3. **Premium HMI Controller (Standard)** — Connect adapter harness 8-pin connector to mating connector on controller harness.
 - a. Attach flat plastic adapter harness connector to rear of controller and secure with supplied #10 screws and washers.

Basic HMI Controller (Optional)— Connect controller harness directly to rear of controller until it locks firmly in position. Adapter harness is not used with this controller.

 - a. Lightly pull on harness to confirm it is locked securely.
4. Attach supplied OPERATOR’S MANUAL nameplate near HMI.

Figure 27. Typical Installation Methods Shown

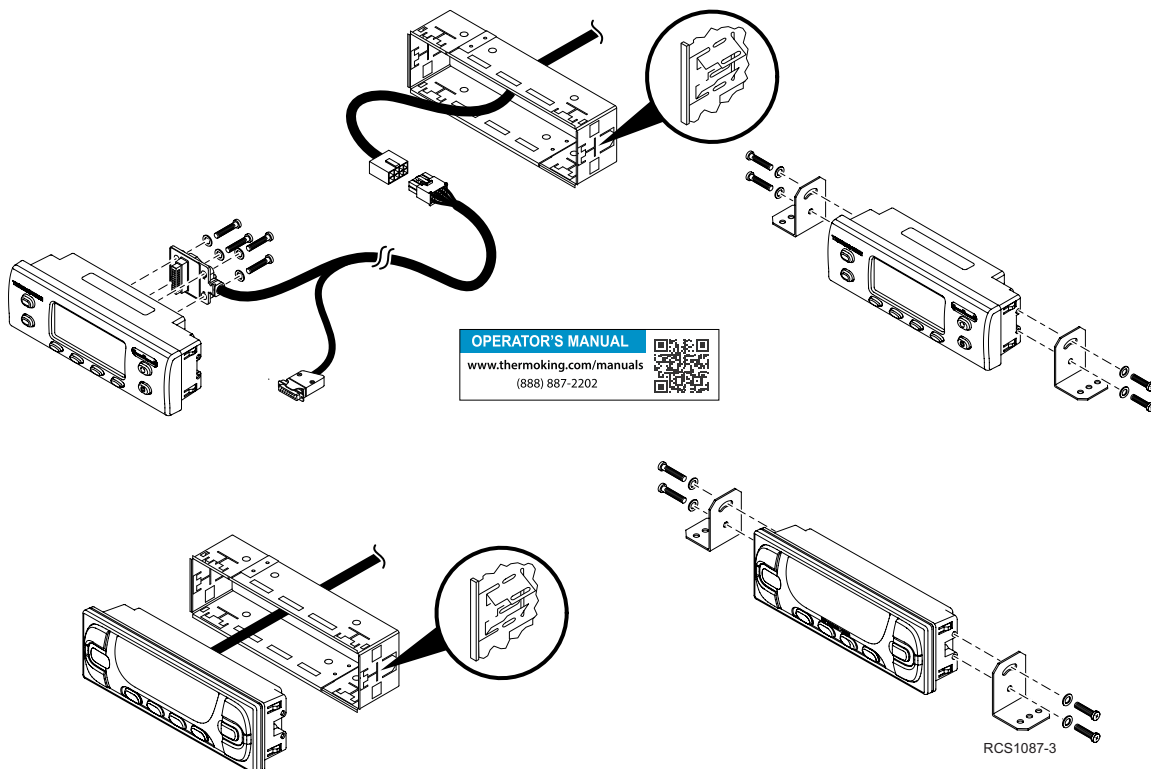

Installing Fuel Pickup Tube

Steel or Aluminum Tank

Important: Safety precautions must be followed. Refer to **Fuel System Component Installation Hazards** located in the **Safety Precautions** section of this manual before proceeding.

Note: The fuel pickup tube supplied in the installation kit will not be needed when also installing an optional Thermo King aluminum fuel tank. The aluminum tank is already equipped with fuel inlet, fuel outlet and vent fittings.

EPA CONFORMANCE: The fuel tank must have a label on the fuel inlet (fill spout) stating " ULTRA-LOW-SULFUR FUEL ONLY". Verify label is present. If not present, order label 93-1184 and install on tank. Reference 40 CFR 1039.104(e)/ 1039.135

IMPORTANT INSTALLATION TIPS

- BEFORE drilling any holes, check for internal baffles inside the tank.
- PRIOR to installation, remove protective caps from ends of pickup tubes.
- DO NOT apply any type of sealant material to the fuel pickup tube assembly. Doing so will result in plugged fuel lines.

Note: Use a magnet, grease or special hole saws/drills that will minimize debris from entering the fuel tank. Thoroughly clean and flush the tank to remove any debris.

FOLLOW THE INSTALLATION INSTRUCTIONS INCLUDED WITH THE FUEL PICKUP TUBE

Figure 28. Typical Steel or Aluminum Fuel Tank Installation Shown

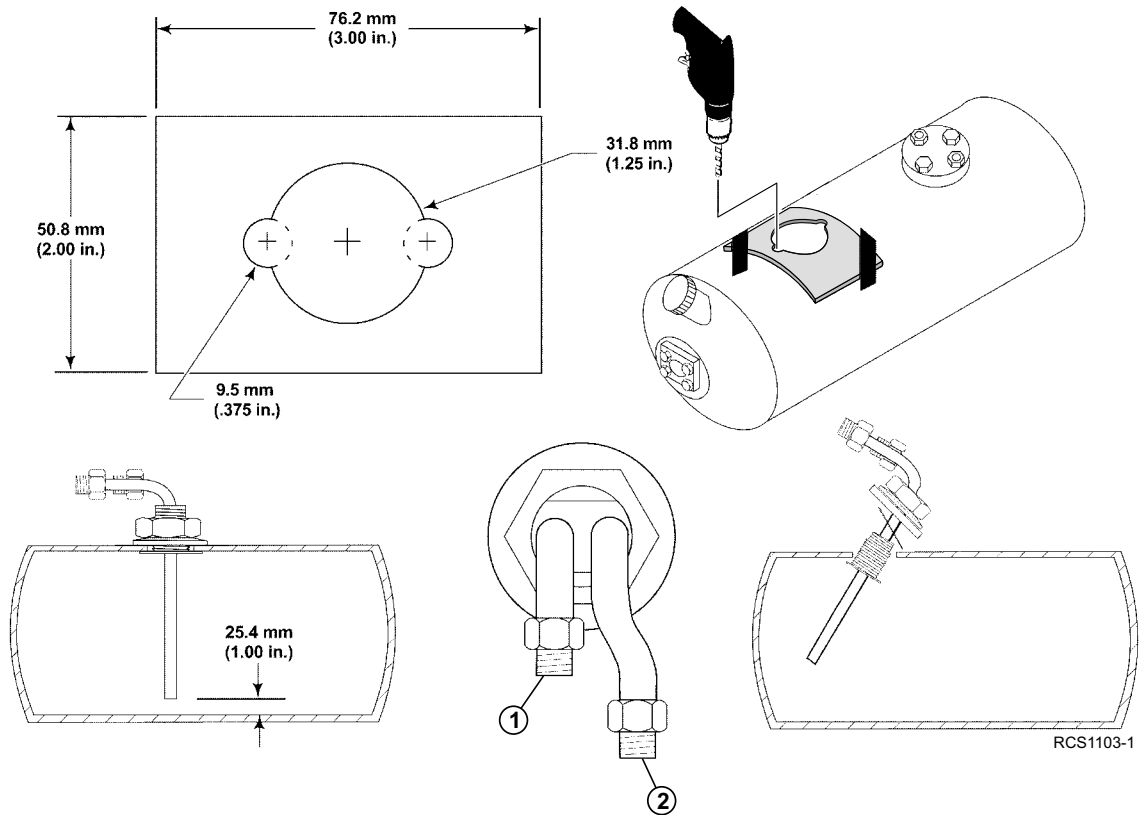

1.	Return Fitting	2.	Supply Fitting
----	----------------	----	----------------

Plastic Tank

Important: Safety precautions must be followed. Refer to **Fuel System Component Installation Hazards** located in the **Safety Precautions** section of this manual before proceeding.

EPA CONFORMANCE: The fuel tank must have a label on the fuel inlet (fill spout) stating "ULTRA-LOW-SULFUR FUEL ONLY". Verify label is present. If not present, order label 93-1184 and install on tank. Reference 40 CFR 1039.104(e)/1039.135

IMPORTANT INSTALLATION TIPS

- BEFORE drilling any holes, check for internal baffles inside the tank.
- PRIOR to installation, remove protective caps from ends of pickup tubes.
- DO NOT apply any type of sealant material to the fuel pickup tube assembly. Doing so will result in plugged fuel lines.

Note: Use a magnet, grease or special hole saws/drills that will minimize debris from entering the fuel tank. Thoroughly clean and flush the tank to remove any debris.

FOLLOW THE INSTALLATION INSTRUCTIONS INCLUDED WITH THE FUEL PICKUP TUBE

Figure 29. Typical Plastic Fuel Tank Installation Shown

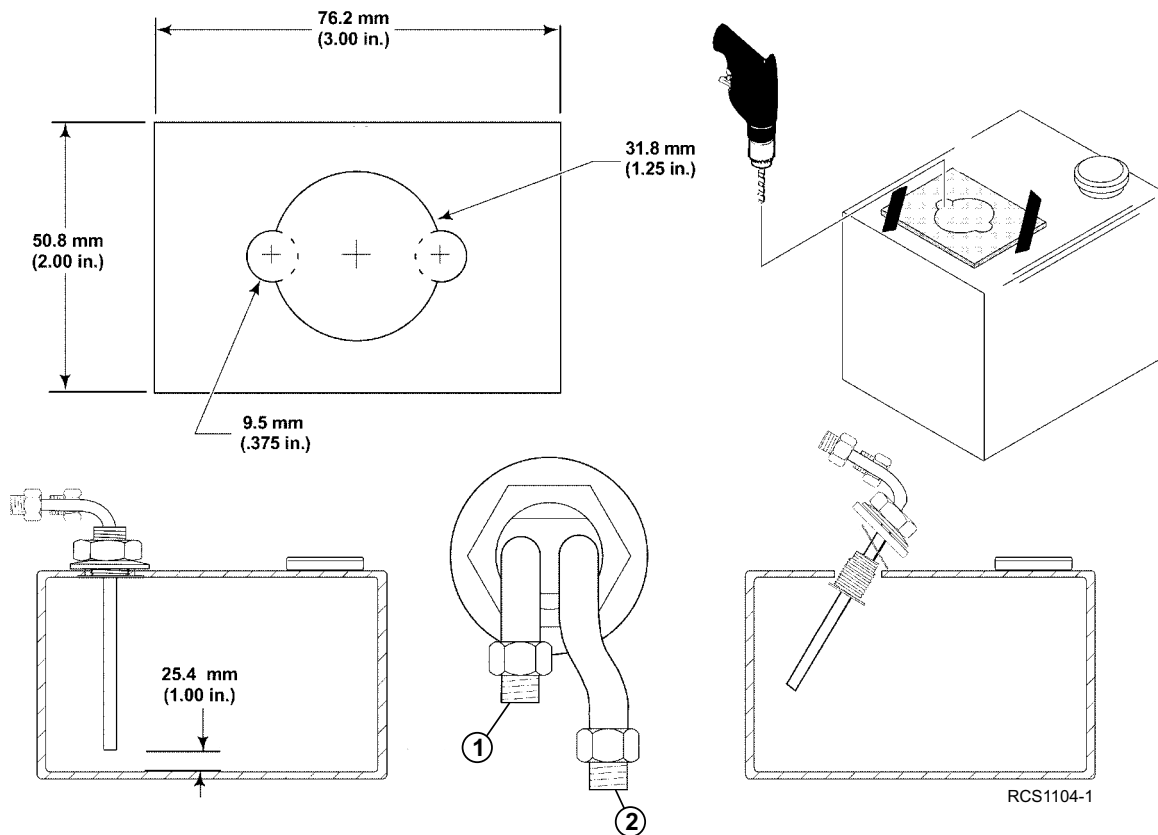

1.	Return Fitting	2.	Supply Fitting
----	----------------	----	----------------

Installing Fuel Pump and Fuel Lines

Important: Safety precautions must be followed. Refer to **Fuel System Component Installation Hazards** located in the **Safety Precautions** section of this manual before proceeding.

FUEL PUMP INSTALLATION

1. Install fuel pump as close to fuel tank as possible and no more than 762 mm (30.00 in.) above the fuel in fuel tank. **See important note below.**

a. Secure pump to vehicle's chassis cross members with supplied mounting bracket and hardware.

Important: Some installation will require the fuel pump harness be extended. An **Optional Extended Chassis Harness** is available that includes a 22 ft. long fuel pump harness.

FUEL LINE INSTALLATION

Note: DO NOT connect unit fuel lines to any truck fuel lines.

Always follow these standards when installing and routing fuel lines:

- a. Fuel lines must be routed in split loom protective sleeving with no kinks or sharp bends.
 - b. Rubber grommets must be used when routing fuel lines through sheet metal.
 - c. All fuel lines must be secured with provided clamps.
2. **Supply Line** from tank to pump — Install fuel line from fuel pickup (supply) fitting to fuel pump (IN) fitting.
 3. **Supply Line** from pump to engine — Connect fuel line from fuel pump (OUT) fitting to unit.
 4. **Return Line** from engine to tank — Connect fuel return line from unit to fuel pickup (return) fitting.
 5. Rotate the fuel tank air vent towards the rear of the truck and remove the plastic end cap.

Important: The factory installed fuel tank air vent must be in place and functional for the Thermo King unit's fuel system to operate correctly and for the fuel tank to remain in compliance with Federal Motor Carrier Safety Administration specifications (title 49, paragraph 393.67). A plugged or restricted fuel tank air vent can result in premature damage to the fuel pump and could also cause severe damage to the fuel tank. **NEVER** remove or install any other component in place of the fuel tank air vent.

Figure 30. Typical Installation Shown

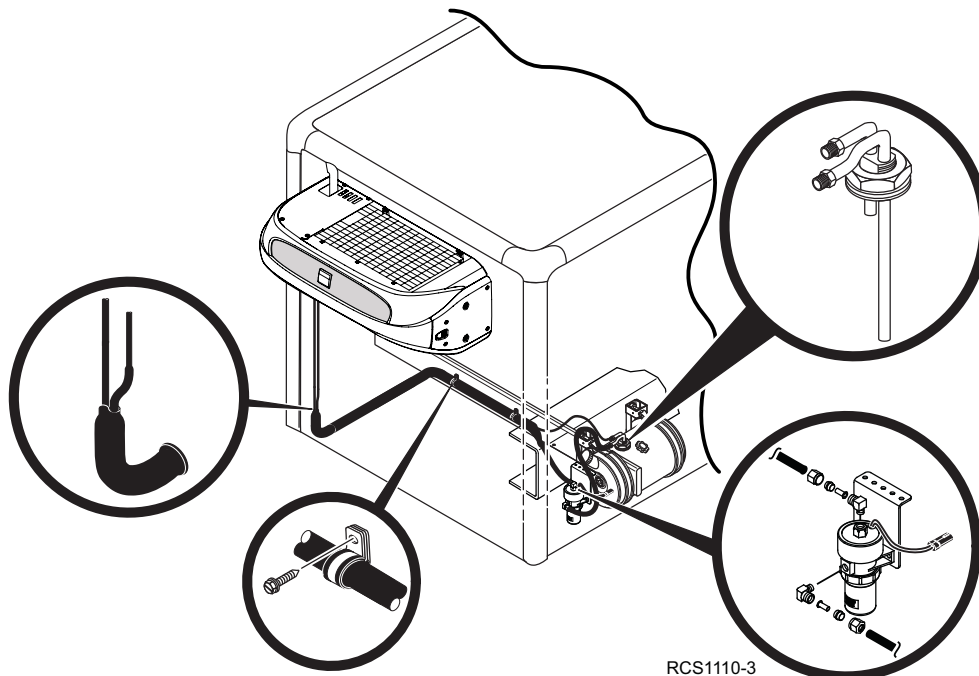

RCS1110-3

Evaporator Installation Standards

Important: Safety precautions must be followed. Refer to the **Safety Precautions** section of this manual before proceeding.

This section defines the Thermo King installation standards to correctly and safely install the SPECTRUM remote evaporators for multi-temperature refrigeration system. Proper installation of each evaporator is critical. Improper installation can not only result in poor system performance, but it can also become a safety concern. It is the responsibility of the installer to follow these standards to assure the components are installed correctly and the unit operates as designed.

Evaporator Locations

Refer to the illustration below.

- Best airflow is achieved when an evaporator is installed an equal distance from each wall.
- It is recommended that moving bulkheads are not allowed closer than 1219 mm (48.00 in.), or one pallet from the evaporator outlet.
- Minimum clearance from bottom of evaporator to top of cargo should be 101 mm (4.00 in.)

Note: This minimum clearance is required under the fan intake area only and does not refer to the cargo box **LOAD LINE**.

- Evaporator should be located a minimum of 51 mm (2.00 in.) from truck cargo box wall.

Figure 31. Evaporator Location Dimensions Shown

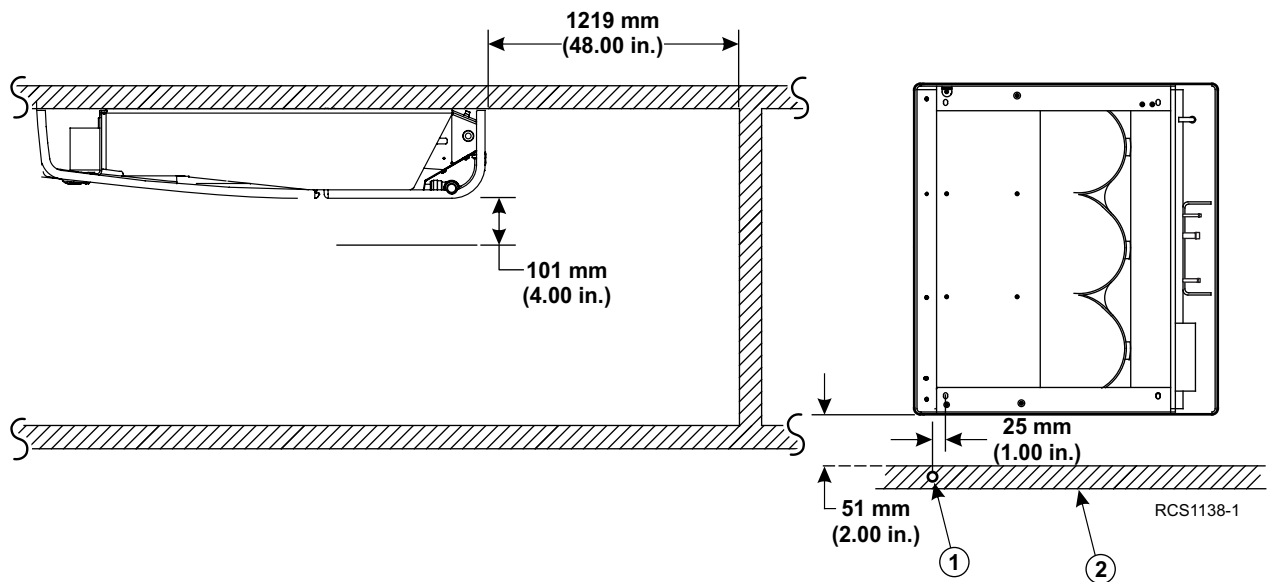

1.	Drain tube located inside cargo box wall	2.	Truck cargo box wall
----	--	----	----------------------

Evaporator Defrost Drains

Refer to the illustration below.

- Evaporator(s) must be properly mounted to provide a slope towards drain. This is accomplished by adding one 3/8 in. and one 3/16 in. washer on drain side and only one 3/8 in. washer on other side at each mounting surface.
- Evaporator(s) should be located a minimum of 51 mm (2.00 in.) from cargo box wall.
- Defrost drains must exit evaporator at a 45° angle. Drains should be 267 mm (10.50 in.) from evaporator to cargo box ceiling.

Cargo Wall Drain Tubes

Refer to the illustration below.

1. Drain tubes must be 25 mm (1.00 in.) ID and made of Chlorinated Polyvinyl Chloride (CPVC) material.
2. Drain tubes must be installed inside cargo box wall.
3. Drain tubes must exit bottom of cargo box wall with no kinks or obstructions and allow condensate to drain freely.

Figure 32. Typical Cargo Wall Drain Tube Details Shown

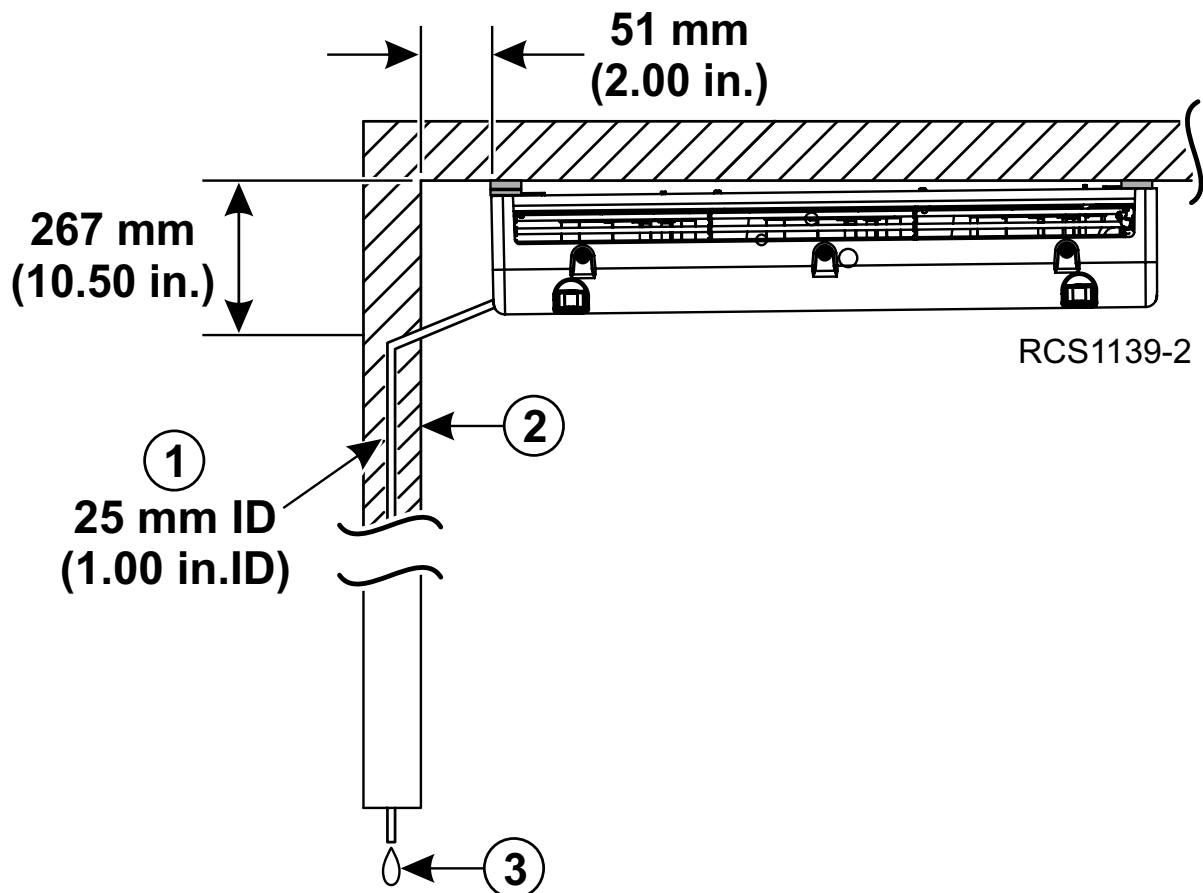



Refrigerant Tubing and Electrical Wiring

Refrigeration Tubing

The following installation standards must be followed:

- Thermo King requires the use of bulk rolled refrigeration tubing and tube benders to reduce fittings and solder joints where applicable. It is also required that the use of nitrogen or another inert gas be used to purge the tubes before soldering. This prevents oxidation and formation of scale inside tubes.
- Clean all tubes and fittings prior to installation and soldering.
- Discard O-rings that come with the condensing unit. Oil and install new O-rings supplied in kit.
Important: Apply refrigerant oil to the O-rings only. **DO NOT APPLY OIL TO THE ORS FITTING THREADS!**
- Clean all threads on ORS fittings prior to installation.
- Each zone needs to have a separate suction line with a check valve installed as close as possible to condensing unit.
Note: Remove internal components of valves before soldering and use 35% silver solder.
- When tightening ORS tubing connections, always use a backup wrench to hold the backside of the ORS fitting to prevent the refrigeration tube from twisting.
- Torque ORS fittings on the condenser to proper specifications.
- Insulation should be added to all segments of suction and hot gas tubes.
- All refrigeration tubes should be routed neatly in a wall or ceiling trough.
- Secure all tubing every 609.6 mm (24.00 in.) with provided clamps.

Electrical Wiring

The following installation standards must be followed:

- Superlube (or equivalent) must be applied to all electrical connectors.
- Electrical connectors must be installed securely to the correct mating connectors at rear of condensing unit.
- Electrical harness should be routed neatly in a wall or ceiling trough.
- Electrical harness should be secured by clamps or tie bands every 600 mm (24.00 in.)
- When installing terminal onto bare wires, you must strip 7 mm (0.25 in.) from the ends and attach the terminals securely using the correct tool.
- Electrical connections to the evaporator terminal strips must be clean and tight.
- Electrical connections the ground studs must be clean and tight.

Wall and Ceiling Troughs

Thermo King recommends enclosed wall or ceiling troughs be used for SPECTRUM multi-temperature applications. Troughs not only protect refrigeration tubes and electrical harnesses from damage, but also help prevent air leakage between compartments.

The following installation standards are recommended:

- Only one trough (Wall or Ceiling) is required.
- Refrigeration tubes should be routed neatly in the trough.
- Refrigeration tubes should be secured by clamps every 600 mm (24.00 in.) inside the trough.
- Electrical harness should be secured by clamps or tie bands every 600 mm (24.00 in.) inside the trough.
- Insulate all hot gas and suction refrigeration tubes inside the trough.
- Trough covers are recommended to protect refrigeration tubes and electrical harnesses from damage.

Figure 33. Refrigerant Tubing and Electrical Wiring Details Shown

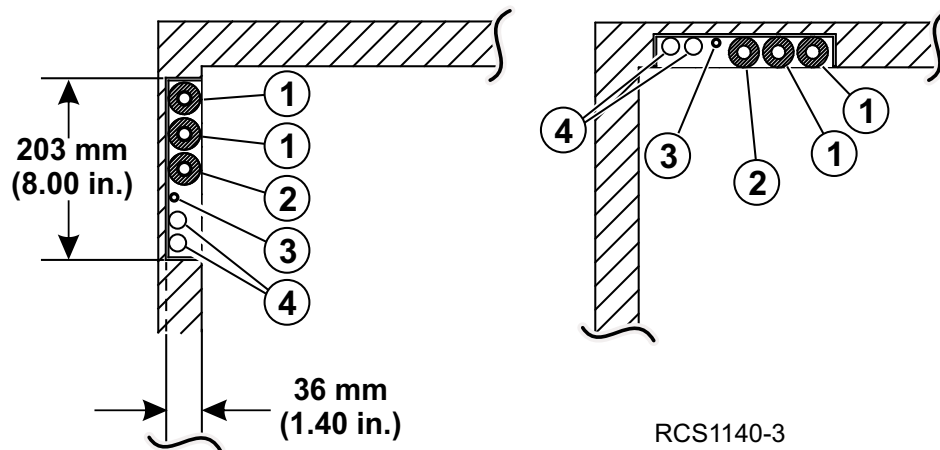

1.	Suction Tube	3.	Liquid Tube
2.	Hot Gas Tube	4.	Electrical Harnesses

Drain Hose Resistance Wire Installation Guide

Important: The following information is provided as a guide to help ensure the proper routing of the drain hose resistance wires. You should supplement this guide with whatever other documentation is required for your facility.

⚠ DANGER

Fire Hazard!

Never bundle evaporator drain hose resistance wires together as the amount of heat produced could result in a fire!

Important: The following points must be followed during installation:

- DO NOT CUT HEATER RESISTANCE WIRES!
- DO NOT install more than one heater resistance wire into each drain tube.
- DO NOT "ball up" or bundle heater resistance wires inside drain tubes.
- DO NOT use band wraps to hold heater resistance wires.
- DO NOT cover or wrap heater resistance wires.
- DO NOT pinch the end of the heater resistance wires tight.

Installation Procedures

1. Pull resistance wire straight out from evaporator drain tube.
2. Locate the evaporator defrost drain furthest from truck/trailer wall (i.e. in the middle of the truck/trailer), and measure 33.00 in. (838 mm) of resistance wire from drain pan outlet (**Detail I**).
3. Bend resistance wire at this point and double it over (**Detail II**).
4. After doubling resistance wire over take excess wire and insert it back into evaporator drain tube (**Detail III**).

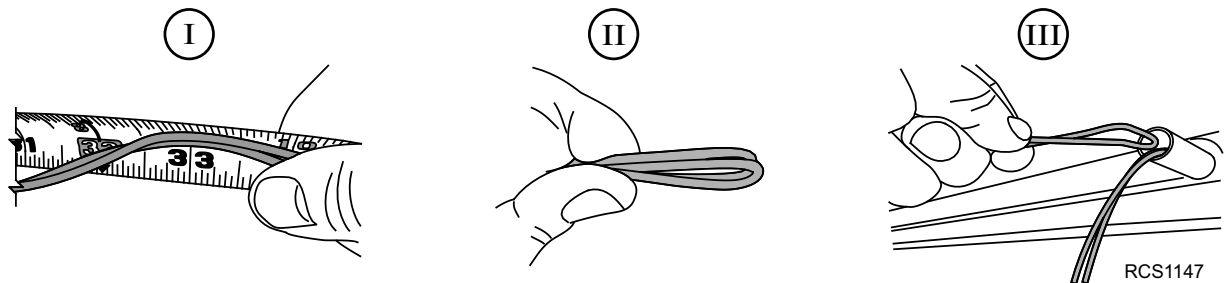

5. Insert doubled over end of resistance wire into drain, Tee, or 90 degree connector (**Detail IV**) and then into crossover drain tube (**Detail V**).

Note: The use of either white or blue drain tubes is acceptable when interconnecting multiple evaporators.

6. Attach drain Tee or 90 degree connector to evaporator drain tube and push connector on firmly to engage O-ring (**Detail VI**).

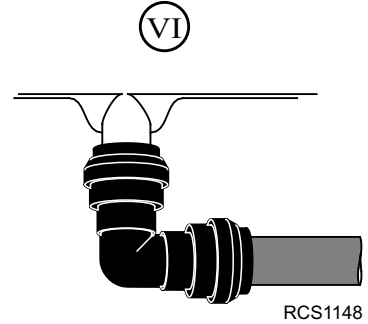
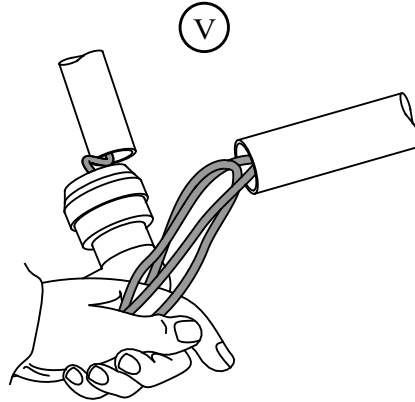
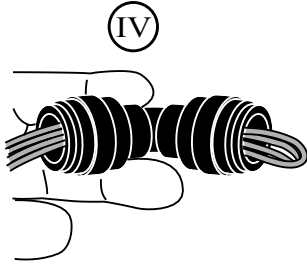

7. Pull resistance wire through interconnecting drain tube as far as possible and make sure it is not bunched up (**Detail VII**).

8. Insert other resistance wire into other drain Tee connector and as shown (**Detail VIII**).

Important: At no time should resistance wires from one side of the drain pan overlap the resistance wires from the other side.

9. Attach interconnecting drain tube to opposite Tee connector by pushing Tee connector on firmly to engage O-ring (**Detail IX**).

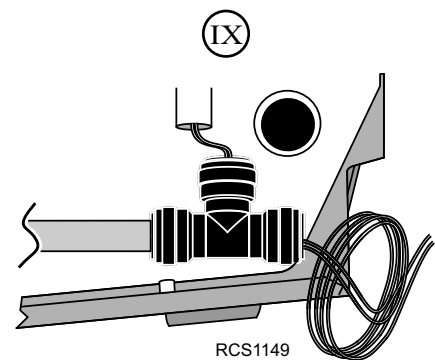
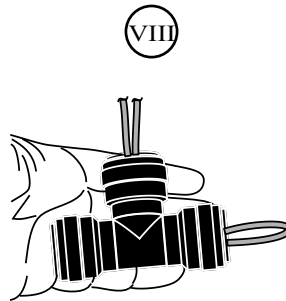
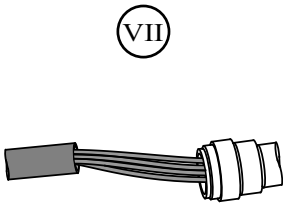

Evaporator Installation Standards

- 10. Attach Tee connector to evaporator drain tube by pushing Tee connector on firmly to engage O-ring (**Detail X**).
- 11. Attach and route evaporator drain tube over to truck/trailer wall drain. Insert resistance wire into truck/trailer wall drain and pull it as far down wall drain as possible (**Detail XI**).

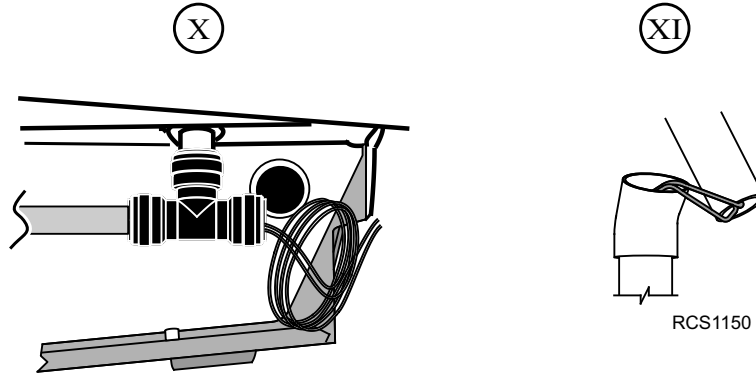

Important: Only one resistance wire should be installed in the wall defrost drain tube. Only the resistance wire from the drain tube closest to the wall should be installed in the trailer drain tube. See illustration below.

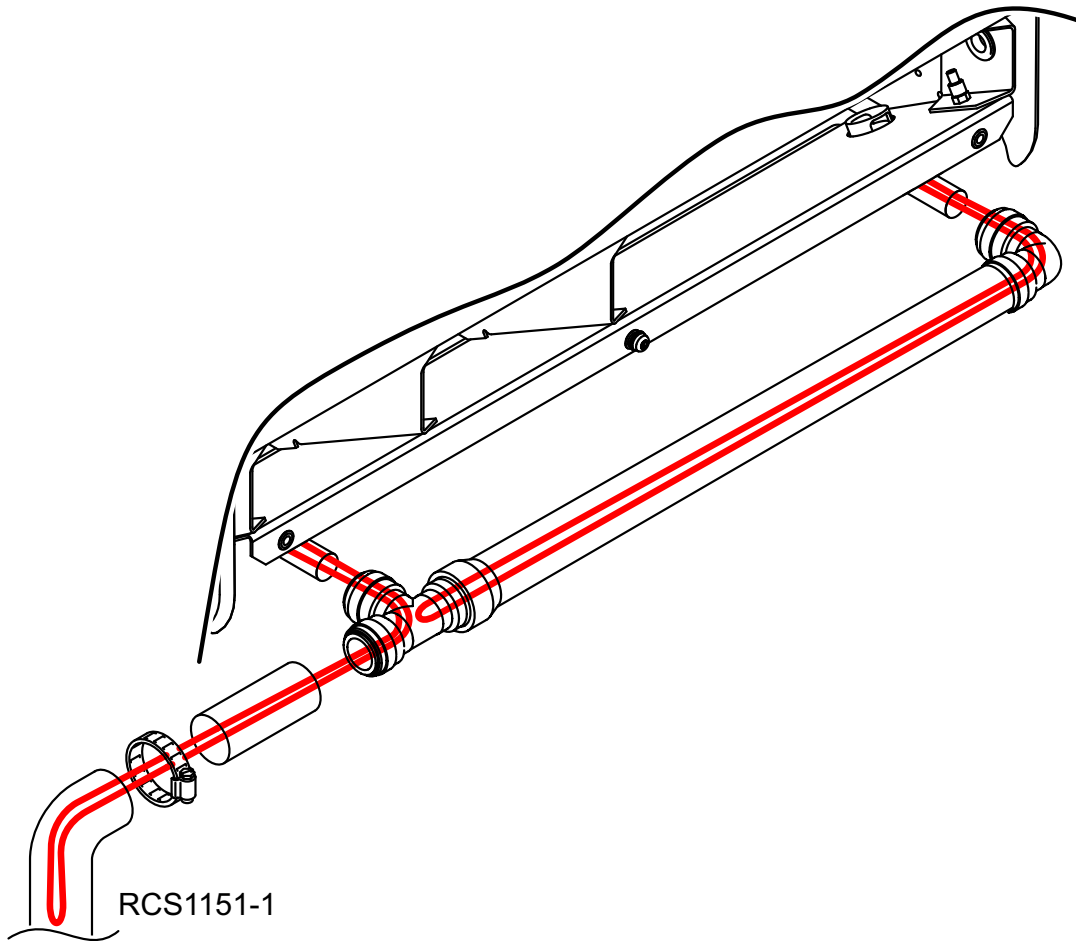

Defrost Drain Tube Connectors

Important: Follow the instructions below to prevent defrost drain tube water leaks.

All Spectrum remote evaporators are equipped with a quick disconnect fitting that connects the drain pan to the drain tubes. To properly install the tube make sure that the tube is fully inserted past the O-ring and up to the stop inside the coupler.

Note: The fitting will grip the tube before it seals with the O-ring.

When the tube is in the correct position the O-ring will seal and the teeth will grip the tube keeping it in place. Check the fit by pulling on the tube(s) to insure that it will not pull out of the fitting.

To disconnect the tube from the fitting: press the collet into the fitting. Hold the collet in place and pull the tube out. The fitting can be re-used. Clean any burrs off the tube before re-inserting it into the fitting.

Figure 34. Defrost Drain Tube Connectors Shown

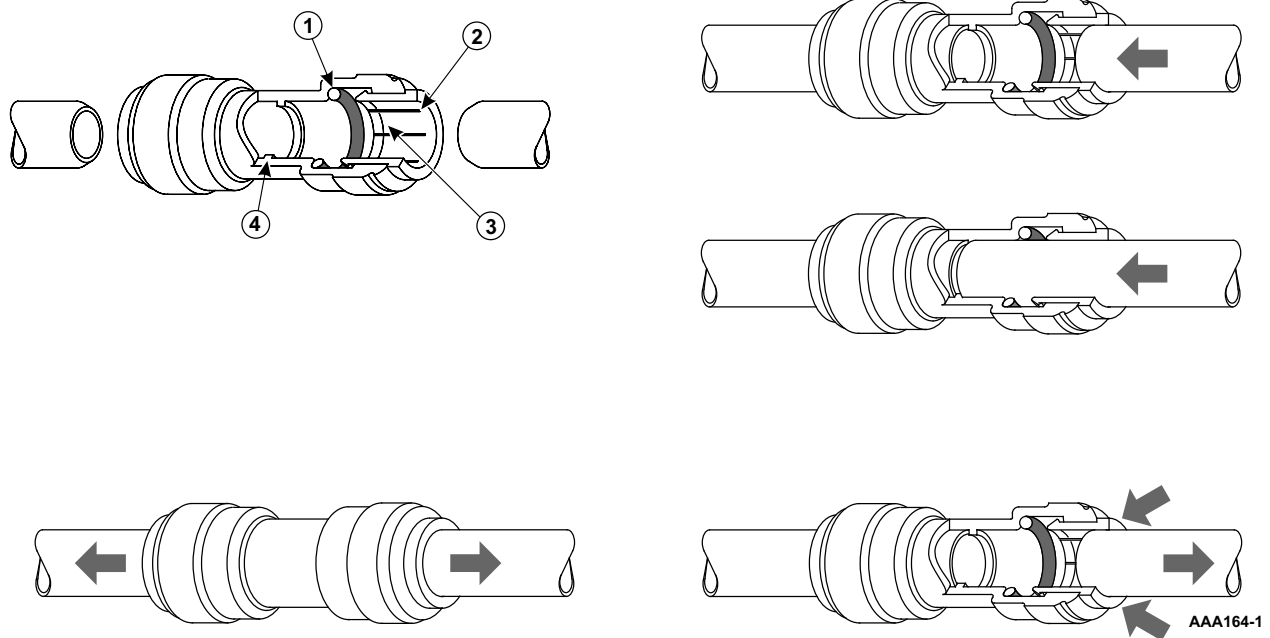

1.	O-Ring	3.	Stainless Steel Teeth
2.	Collet	4.	Stop



Transverse Drain (Option)

Important: A transverse drain is required to drain on one side toward the front or back of the truck.

Figure 35. Transverse Drain Option Shown

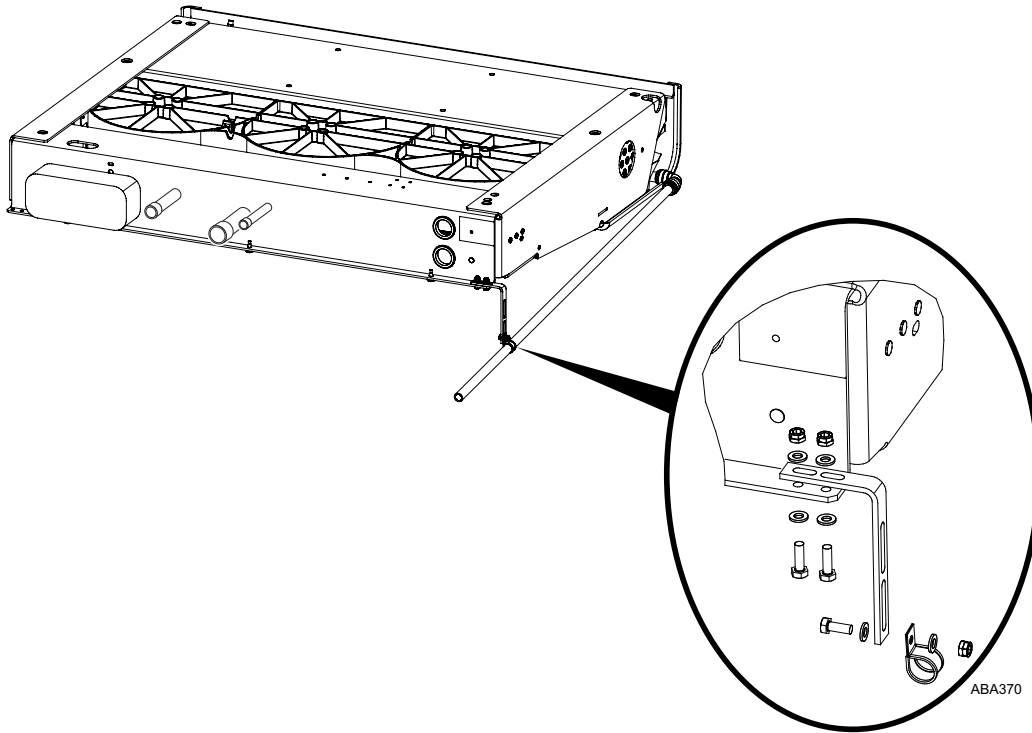

Evaporator Cap Plugs

Cap plugs are provided to plug the two evaporator mounting access holes located directly above the drain pan. These plugs must be installed to prevent water in the drain pan from spilling out of these holes and into the cargo area.

Important: Always install cap plugs after installing the evaporator(s).

Figure 36. Two Cap Plugs Per Evaporator Required

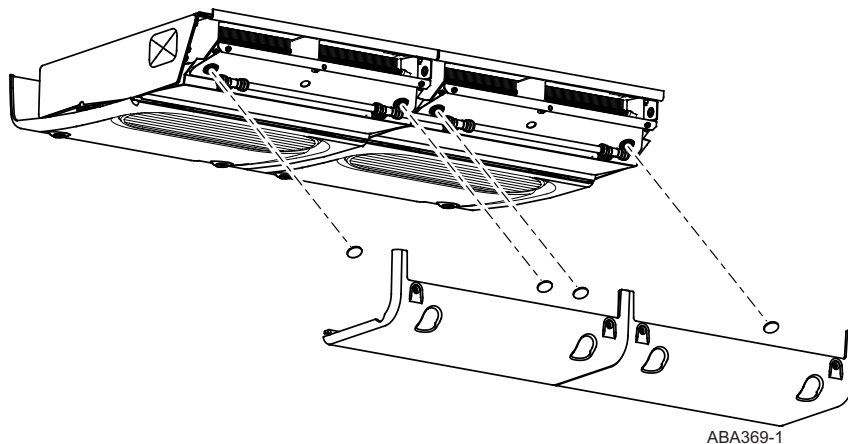

Removing the Holding Charge

Important: Safety precautions must be followed. Refer to **Unit Installation Hazards** in the **Safety Precautions** section of this manual before proceeding.

Note: Always keep the holding charge in the condensing unit and the remote evaporators until ready to connect the tubing.

Condensing Unit

Slowly remove the ORS caps from the hot gas, liquid and suction lines at rear of the condensing unit to release the nitrogen holding charge.

Remote Evaporators

Slowly remove the solder caps from the hot gas, liquid and suction lines at rear of each evaporator to release the nitrogen holding charge.

Figure 37. ORS and Solder Cap Locations Shown

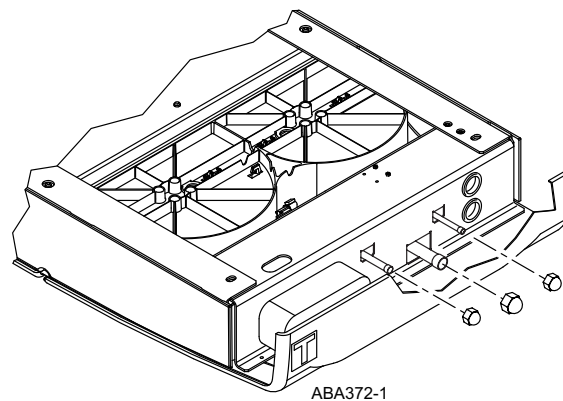
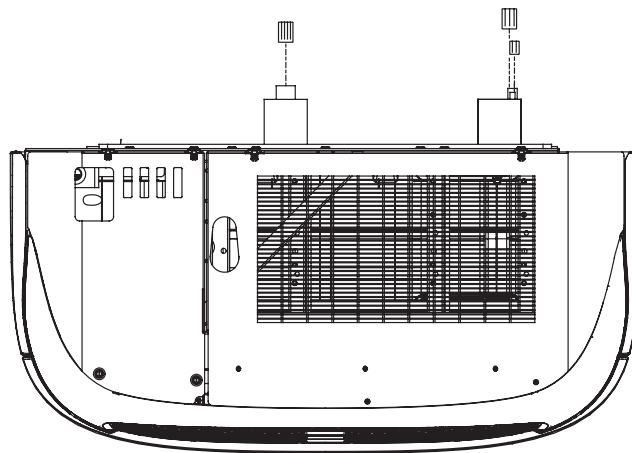

Evaporator Installation Components

Basic S-2 and S-3 Installation Components

Note: The following components are shipped with all S-2 and S-3 evaporators.

1. Pre-Bent Liquid, Hot Gas and Suction Tubes
2. Pre-Formed Drain Hose 3/4" ID
3. Hose Clamp
4. Water Drain Pipe
5. Water Drain Elbow
6. Terminal Fork Connectors
7. Terminal Ring Connectors
8. Refrigerant Oil
9. Mounting Spacers (3 sizes)
10. Locking Nuts 1/2-13
11. Flat Washer 1/2"
12. Flat Washer 3/8"
13. Locking Nut M10-1.5
14. Cap Plugs
15. Tubing Clamps
16. Screws 1/4-20
17. Flat Washers 1/4"
18. Locking Nut 1/4-20
19. Copper Elbows, 3/8", 1/2" and 7/8"
20. Side Covers
21. Screws M6 Torx

Figure 38. Basic S-2 and S-3 Installation Components – Shipped with all S-2 and S-3 evaporators

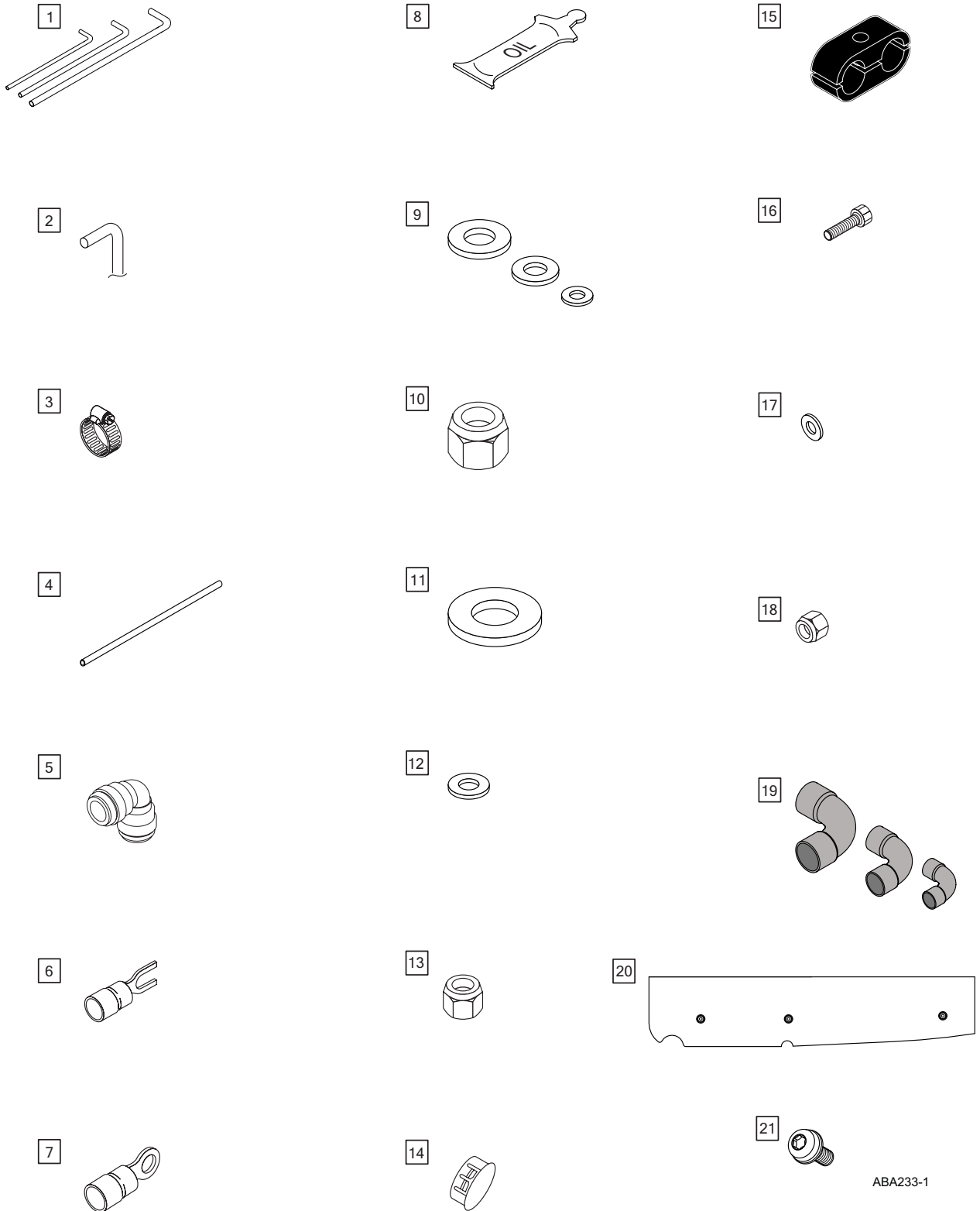

ABA233-1



THERMO KING

Evaporator Installation Components

Two and Three Zone S-2 or S-3 Installation Components

Note: The following components are required and ordered separately (Kit 801277 or 801280) based on the installation configuration.

1. ORS Pre-bent Tubes
2. ORS Adapters
3. O-rings
4. Check Valves
5. Copper Elbows
6. Copper Tee's
7. Tube Insulation
8. Insulated Clamps
9. Steel Clamps
10. Self Drilling Screws
11. Washers
12. Band Wraps
13. Terminal Socket Pins
14. Remote Evaporator Harnesses

Figure 39. Evaporator Installation Components — Two and Three Zone S-2 or S-3 Installations

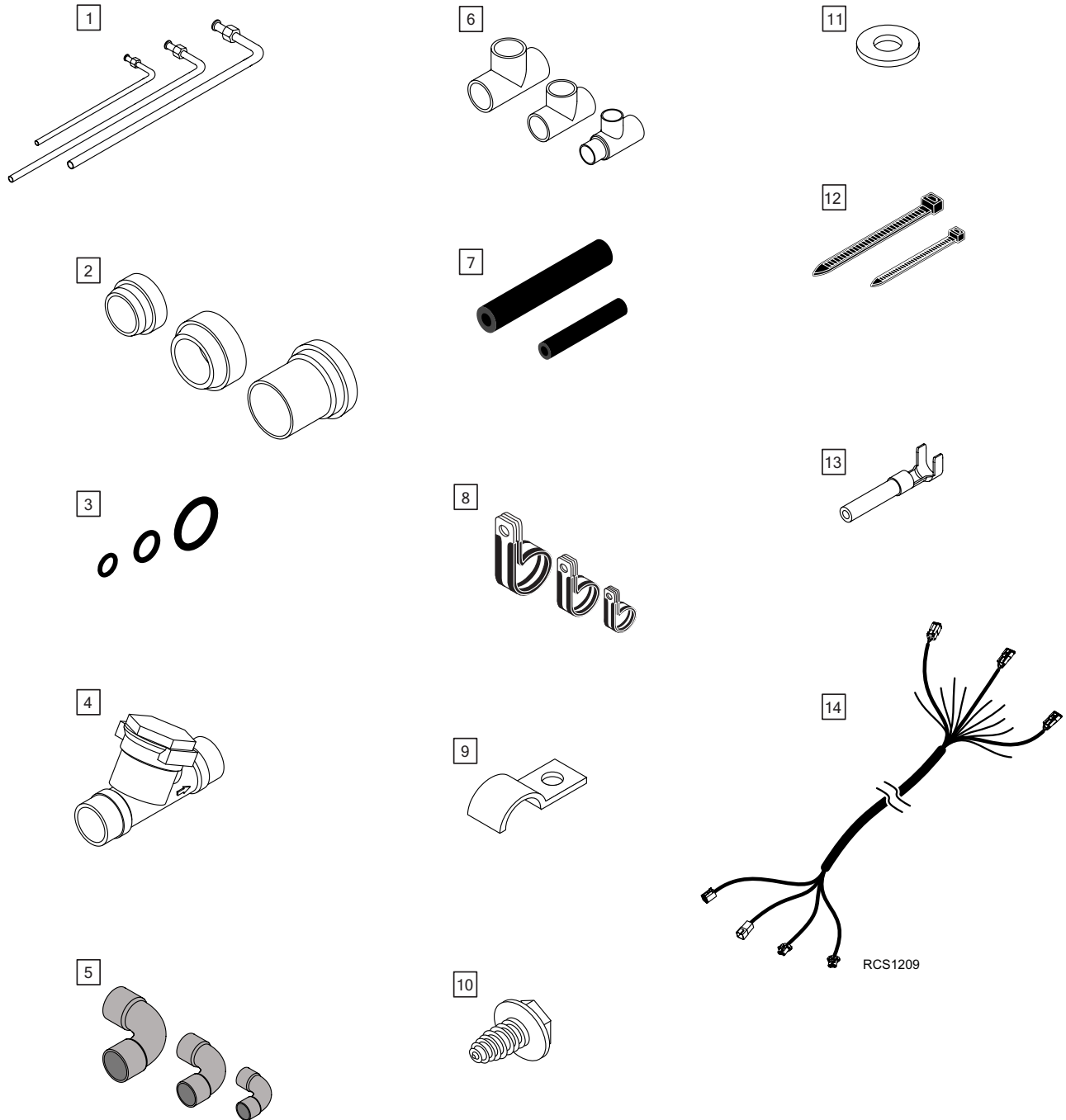



Two Zone S-2 + S-2 Installation Components

Note: The following components are required and ordered separately (Kit 800372) for a S-2 + S-2 installation configuration.

1. Copper Elbows
2. Copper Tee's
3. Terminal Fork Connectors
4. Terminal Ring Connectors
5. Check Valve
6. Tee Assembly - Liquid Line
7. Tee Assembly - Hot Gas Line
8. Insulated Clamps
9. Evaporator Interconnect Harness

Figure 40. Evaporator Installation Components – Two Zone S-2 + S-2 Installations

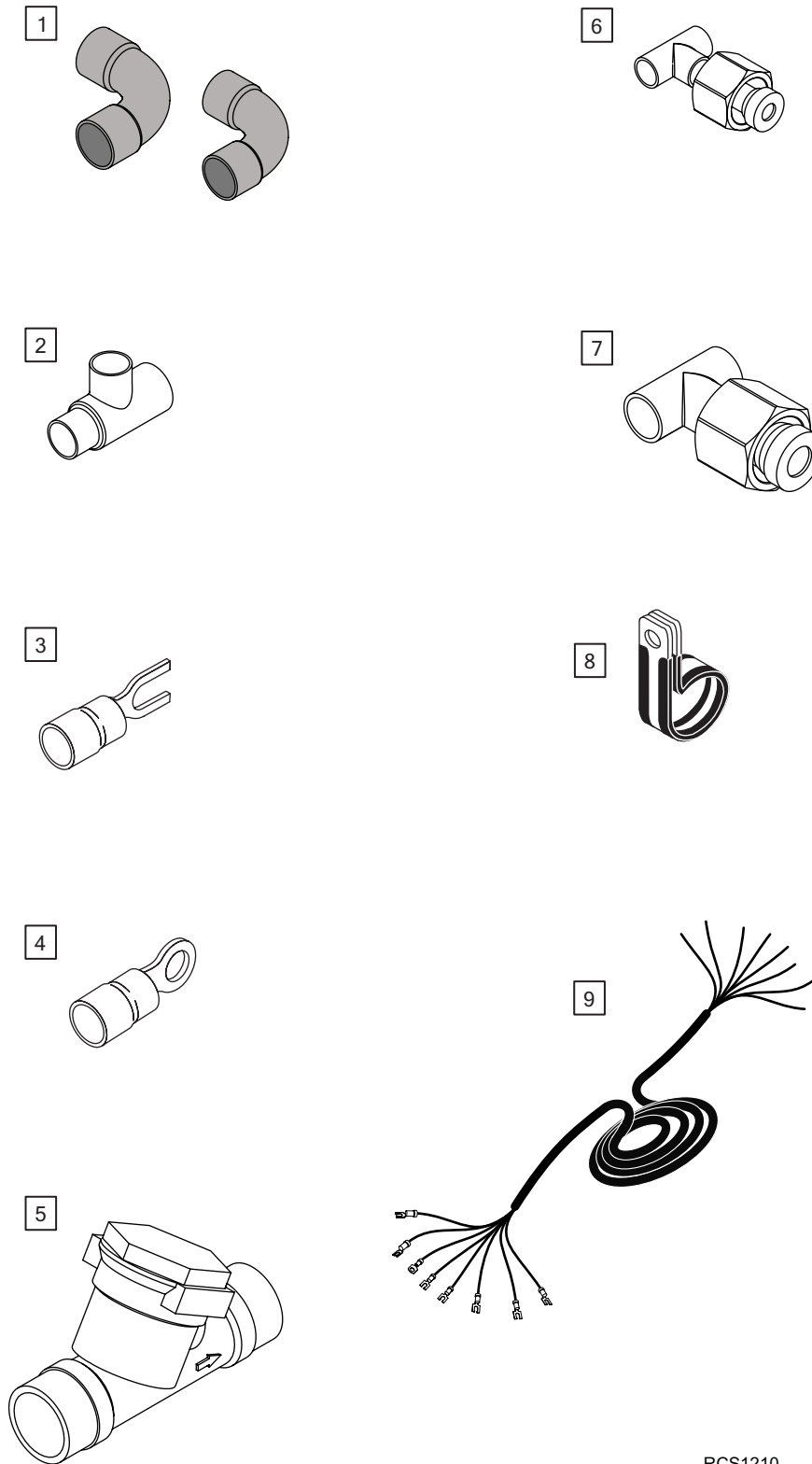

RCS1210

Installing Evaporators

Ceiling Preparation

Refer to the illustration on the following page.

Important: Safety precautions must be followed. Refer to **Unit Installation Hazards** located in the **Safety Precautions** section of this manual before proceeding.

Important: Truck ceiling must be structurally strong enough to support the weight of the evaporator(s).

Important: Truck ceiling must be flat and mounting locations correct for proper remote evaporator installation. Foam insulation in ceiling must be removed from evaporator mounting area and aluminium spacers must be installed between evaporator mounting plate and trailer ceiling.

Note: If truck ceiling frame is other than aluminum, use mylar film between aluminum spacer and frame.

- For ceiling mounting **stud** applications, weld a nut (same thread as stud) onto a 44.45 mm (1.75 in.) hole saw and turn the nut onto mounting stud using a socket wrench.
- For ceiling mounting **bolt** applications, weld a bolt (same thread as tapped hole) onto a 44.45 mm (1.75 in.) hole saw and turn into tapped mounting hole using a socket wrench.
- Alternative method is to remove mounting studs or bolts and use a hole saw with a standard pilot drill small enough to run up into threaded hole without damaging the threads. Reinstall mounting studs or bolts.

Mounting Stud or Bolt Requirements

Refer to the illustration on the following page.

The mounting studs or bolts used to attach the evaporator(s) to the ceiling must be 10.0 mm, (0.50 in., Grade 5, U.S. applications only), medium carbon steel, 120000 PSI tensile strength, cadmium plate and dichromate finish. Studs to extend below ceiling 38.0 mm (1.50 in.) to 50.1 mm (2.00 in.)

Note: The installation kit provides both 10.0 mm metric and 0.50 in. imperial nuts and washers. Be sure to use the correct ones for your application.

S-2 or S-3 Evaporator Installation

Refer to the illustration on the following page.

Important: Evaporator must be properly mounted to provide a slope towards drain. This is accomplished by adding one 3/8 in. and one 3/16 in. washers on the drain side and only one 3/8 in. washer on the other side at each mounting surface.

1. Remove evaporator cover to access mounting holes.
2. Install aluminum spacers onto ceiling mounting studs and raise the evaporator into position. Secure evaporator onto mounting studs with flat washers and locking nuts. Torque to 81.3 N•m (60 ft-lb).
3. Install mounting bolts, lock washers (installer supplied) and flat washers onto the evaporator and raise into position. Install aluminium spacers and secure evaporator to ceiling. Torque to 81.3 N•m (60 ft-lb).
4. A properly installed evaporator will slope slightly toward the drain tubes to allow for water drainage. Two additional washers are included in the kit to help assist sloping the evaporator towards the drain.

Figure 41. Typical Evaporator Installations Shown

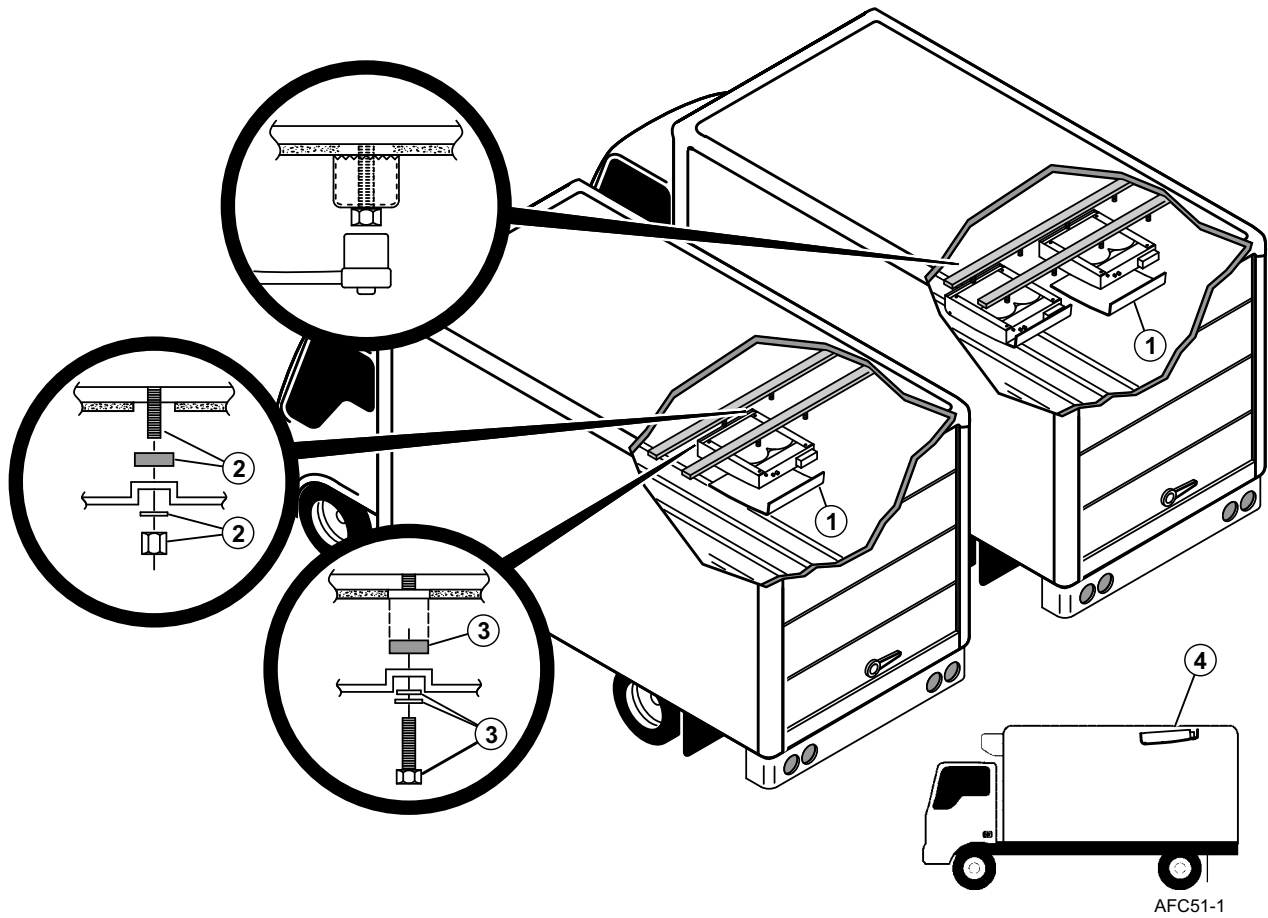

AFC51-1

Refrigeration Tubing Connections

S-2 or S-3 Installations

Important: Safety precautions must be followed. Refer to **Unit Installation Hazards** located in the **Safety Precautions** section of this manual before proceeding.

Connections at Condensing Unit

Refer to the illustrations on the following pages.

The following installation standards must be followed:

- Thermo King requires the use of bulk rolled refrigeration tubing and tube benders to reduce fittings and solder joints where applicable. It is also required that the use of nitrogen or another inert gas be used to purge the tubes before soldering. This prevents oxidation and formation of scale inside tubes.
- Clean all tubes and fittings prior to installation and soldering.
- Discard O-rings that come with the condensing unit. Oil and install new O-rings supplied in kit.
- Clean all threads on ORS fittings prior to installation.
- Apply refrigerant oil to the O-rings only. **DO NOT APPLY OIL TO THE ORS FITTING THREADS!**
- Each zone needs to have a separate suction line with a check valve installed as close as possible to condensing unit.
Note: Remove internal components of valves before soldering and use 35% silver solder.
- When tightening ORS tubing connections, always use a backup wrench to hold the backside of the ORS fitting to prevent the refrigeration tube from twisting.
- Torque ORS fittings on the condenser as shown in the table below.
- Insulation should be added to all segments of suction and hot gas tubes.
- Secure all tubing every 609.6 mm (24.00 in.) with provided clamps.

Specifications for ORS Fittings				
Tube	Size	Thread	Torque	O-Ring Gaskets P/N
Liquid	3/8 in.	11/16-16	16-17 ft-lb	331015
Hot Gas	1/2 in.	13/16-16	32-35 ft-lb	330566
Suction	1-1/8 in.	1-11/16 -12	93-102 ft-lb	331777

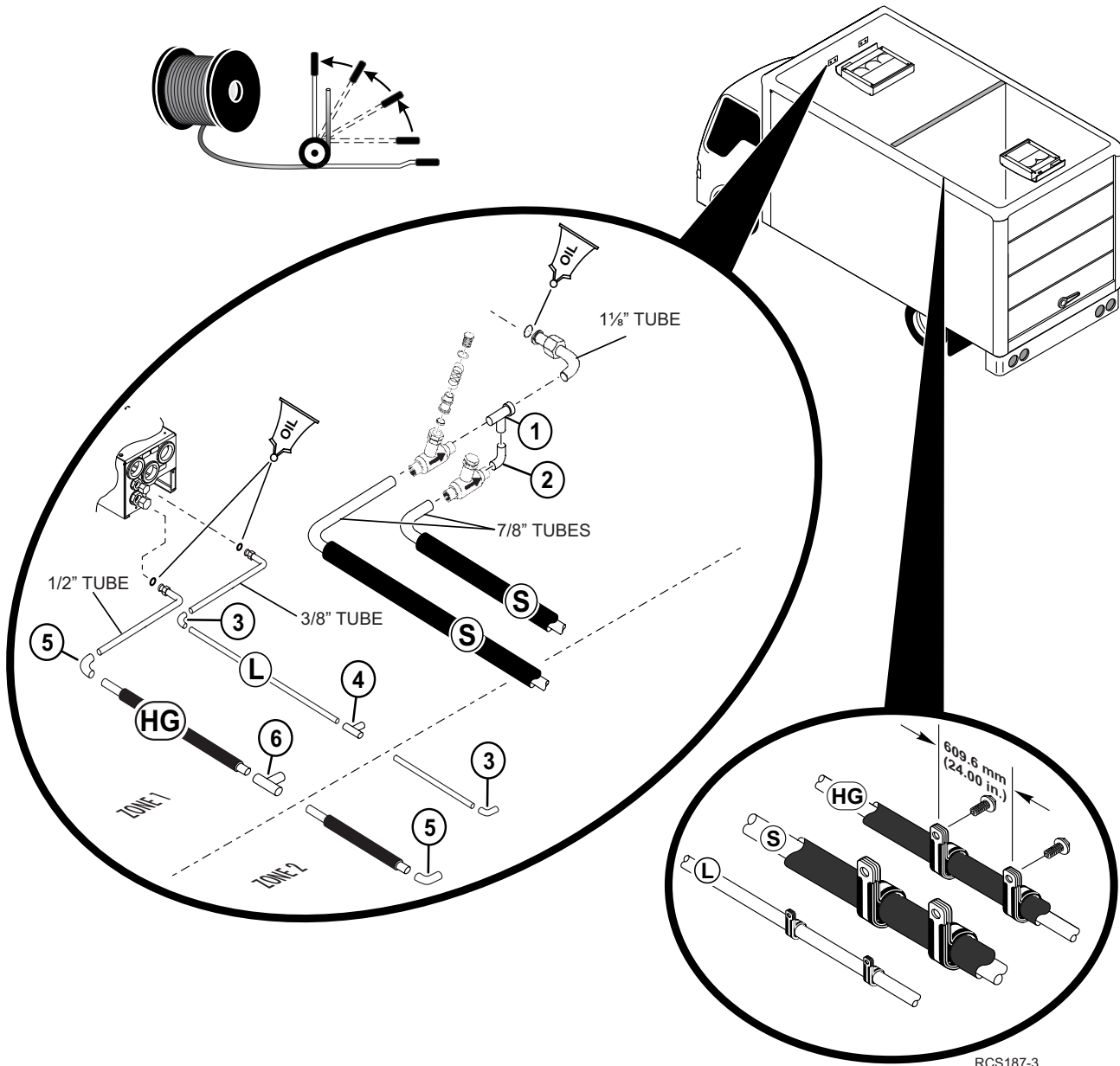
Figure 42. Condensing Unit Connections Shown

RCS187-3

The copper fittings in the illustration are shown in the table below.

Item	Description	P/N
#1	Tee 1-1/8 in. x 7/8 in. x 7/8 in.	558968
#2	90° Elbow 7/8 in. x 7/8 in.	553326
#3	90° Elbow 3/8 in. x 3/8 in.	552876
#4	Tee 3/8 in. x 3/8 in. x 3/8 in.	553251
#5	90° Elbow 1/2 in. x 1/2 in.	558812
#6	Tee 1/2 in. x 1/2 in. x 1/2 in.	552296



Connections at Evaporator

Figure 43. Evaporator Connections

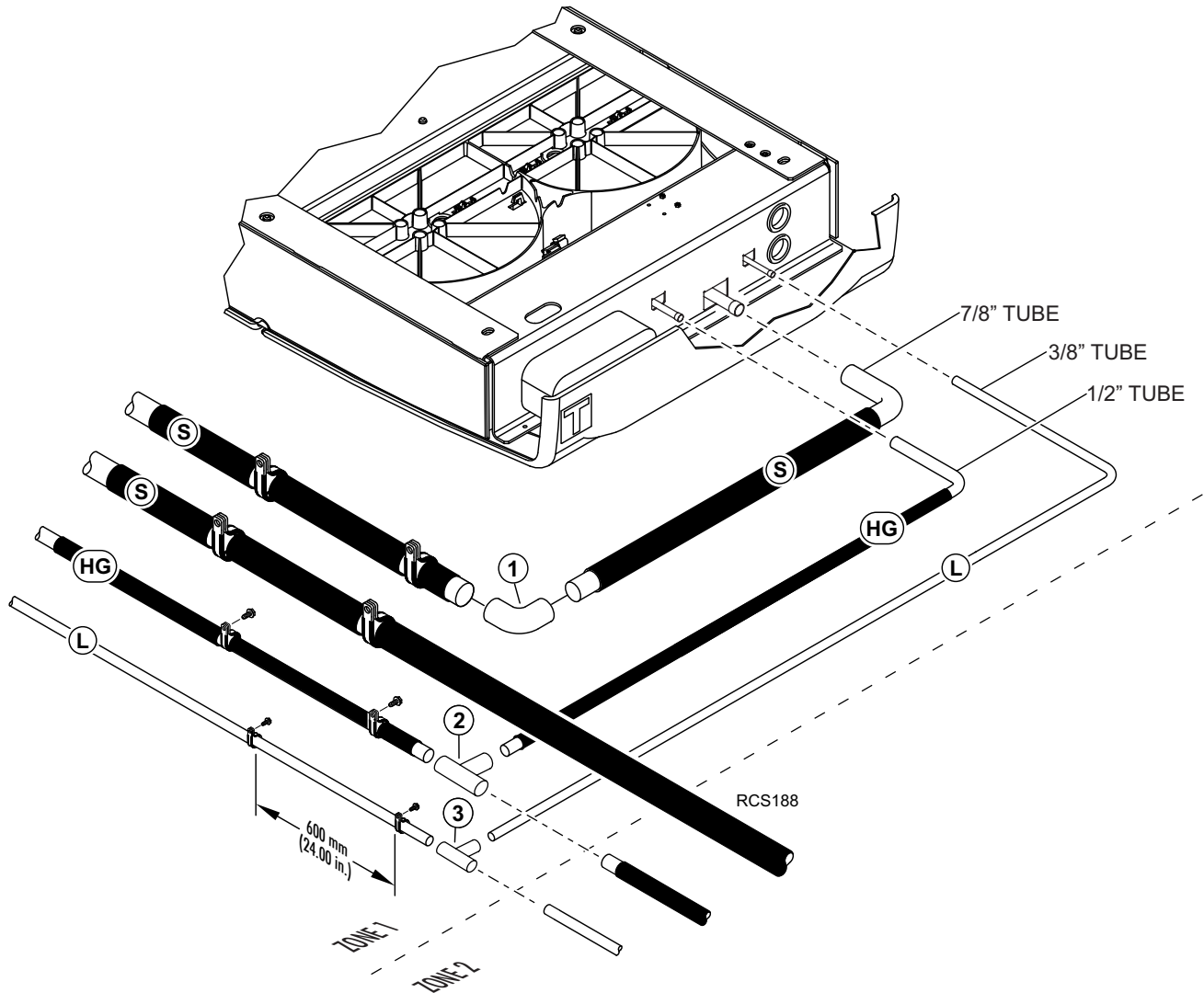

The copper fittings in the illustration are shown in the table below.

Item	Description	P/N
#1	90° Elbow 7/8 in. x 7/8 in.	553326
#2	Tee 1/2 in. x 1/2 in. x 1/2 in.	552296
#3	Tee 3/8 in. x 3/8 in. x 3/8 in.	553251

S-2 + S-2 Installations

Important: Safety precautions must be followed. Refer to **Unit Installation Hazards** located in the **Safety Precautions** section of this manual before proceeding.

Connections at Condensing Unit

Refer to the illustrations on the following pages.

The following installation standards must be followed:

- Thermo King requires the use of bulk rolled refrigeration tubing and tube benders to reduce fittings and solder joints where applicable. It is also required that the use of nitrogen or another inert gas be used to purge the tubes before soldering. This prevents oxidation and formation of scale inside tubes.
- Clean all tubes and fittings prior to installation and soldering.
- Discard O-rings that come with the condensing unit. Oil and install new O-rings supplied in kit.
- Clean all threads on ORS fittings prior to installation.
- Apply refrigerant oil to the O-rings only. **DO NOT APPLY OIL TO THE ORS FITTING THREADS!**
- Each zone needs to have a separate suction line with a check valve installed as close as possible to condensing unit.
Note: Remove internal components of valves before soldering and use 35% silver solder.
- When tightening ORS tubing connections, always use a backup wrench to hold the backside of the ORS fitting to prevent the refrigeration tube from twisting.
- Torque ORS fittings on the condenser as shown in the table below.
- Insulation should be added to all segments of suction and hot gas tubes.
- Secure all tubing every 609.6 mm (24.00 in.) with provided clamps.

Specifications for ORS Fittings				
Tube	Size	Thread	Torque	O-Ring Gaskets P/N
Liquid	3/8 in.	11/16-16	16-17 ft-lb	331015
Hot Gas	1/2 in.	13/16-16	32-35 ft-lb	330566
Suction	1-1/8 in.	1-11/16-12	93-102 ft-lb	331777

Figure 44. Condensing Unit Connections Shown

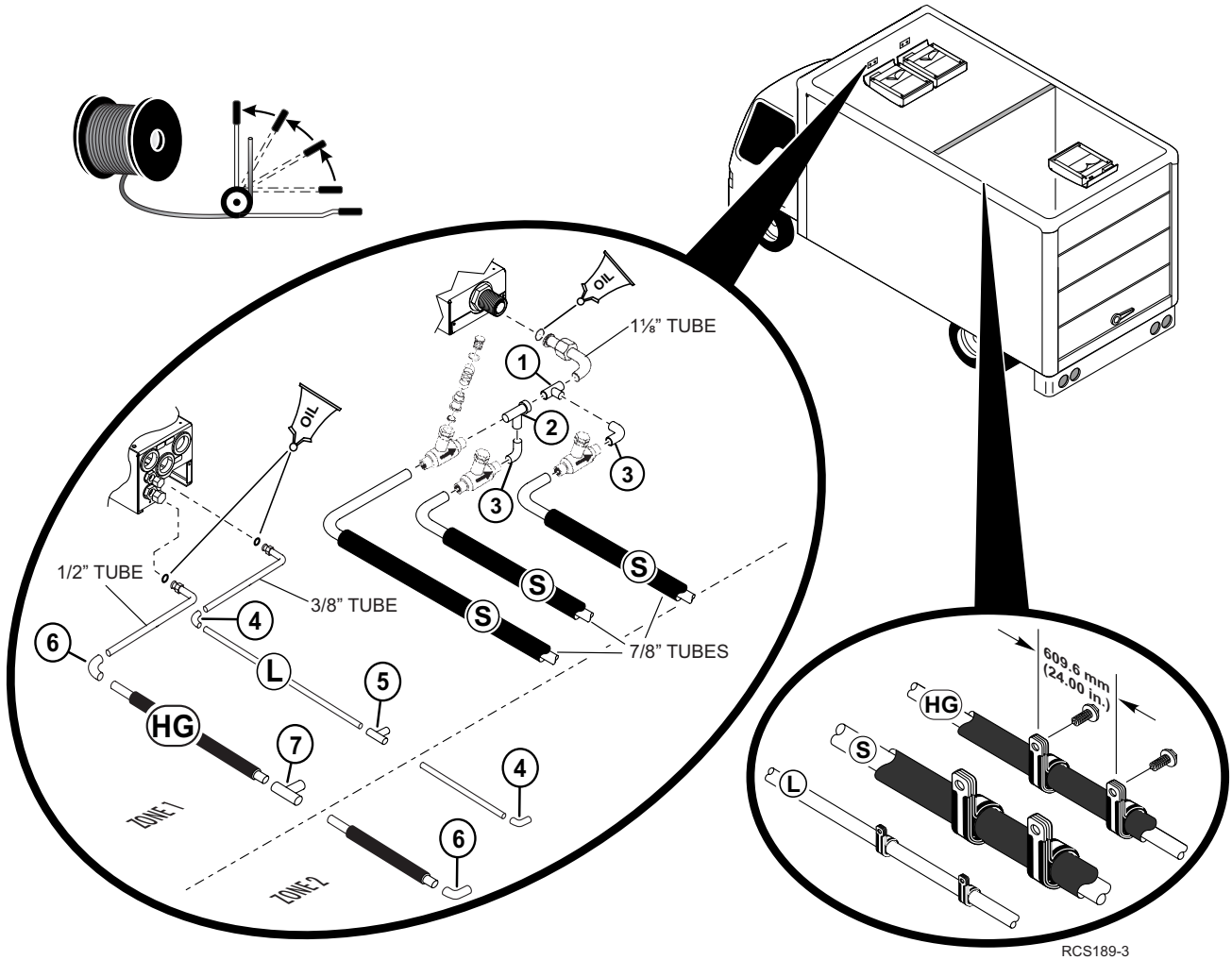

The copper fittings in the illustration are shown in the table below.

Item	Description	P/N
#1	Tee 1-1/8 in. x 1-1/8 in. x 7/8 in.	559517
#2	Tee 1-1/8 in. x 7/8 in. x 7/8 in.	558968
#3	90° Elbow 7/8 in. x 7/8 in.	553326
#4	90° Elbow 3/8 in. x 3/8 in.	552876
#5	Tee 3/8 in. x 3/8 in. x 3/8 in..	553251
#6	90° Elbow 1/2 in. x 1/2 in.	558812
#7	Tee 1/2 in. x 1/2 in. x 1/2 in.	552296

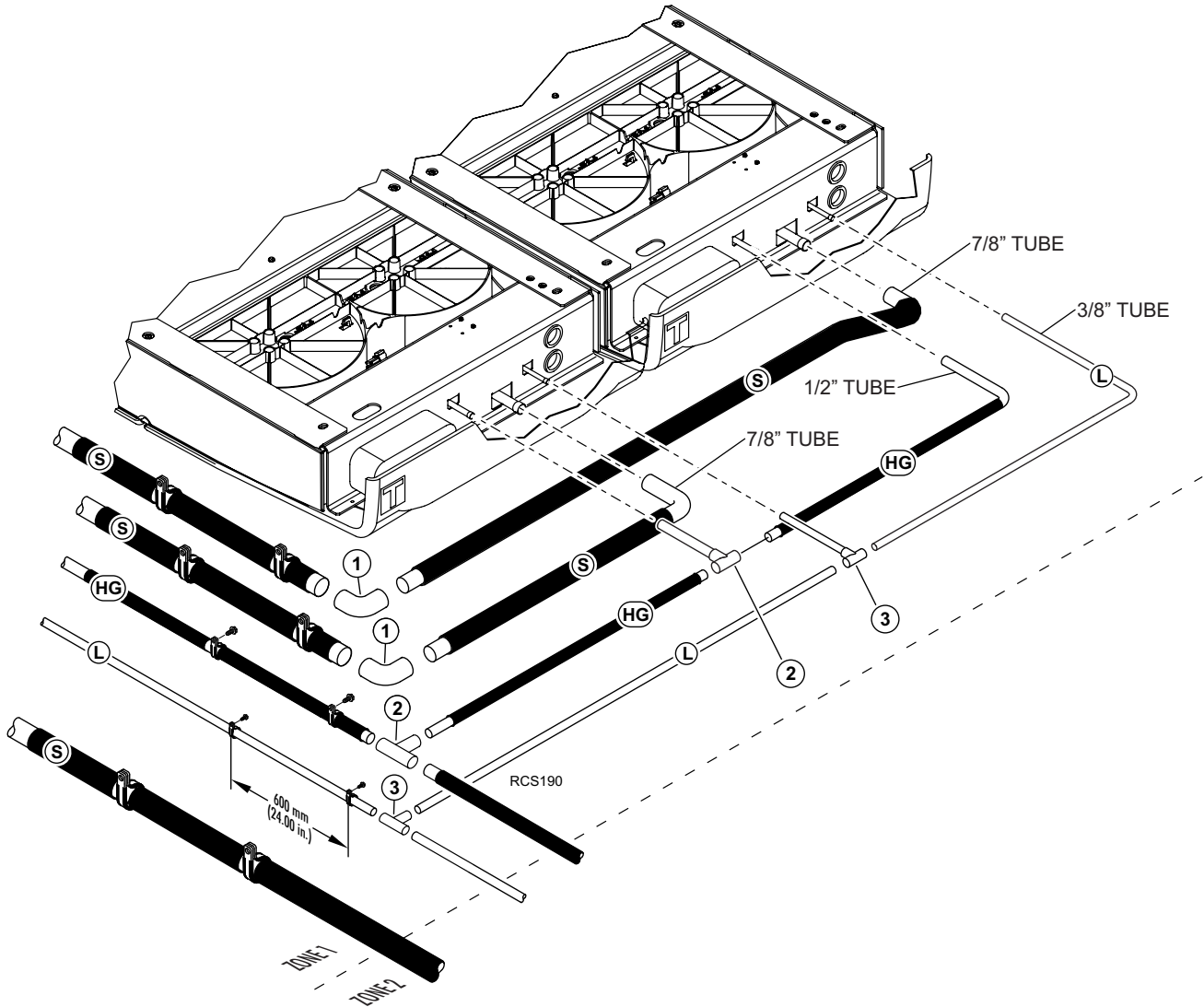
Connections at Evaporator
Figure 45. Evaporator Connections Shown

The copper fittings in the illustration are shown in the table below.

Item	Description	P/N
#1	90° Elbow 7/8 in. x 7/8 in.	553326
#2	Tee 1/2 in. x 1/2 in. x 1/2 in.	552296
#3	Tee 3/8 in. x 3/8 in. x 3/8 in.	553251



Three Zone Installations

Important: Safety precautions must be followed. Refer to **Unit Installation Hazards** located in the **Safety Precautions** section of this manual before proceeding.

Connections at Condensing Unit

Refer to the illustrations on the following pages.

The following installation standards must be followed:

- Thermo King requires the use of bulk rolled refrigeration tubing and tube benders to reduce fittings and solder joints where applicable. It is also required that the use of nitrogen or another inert gas be used to purge the tubes before soldering. This prevents oxidation and formation of scale inside tubes.
- Clean all tubes and fittings prior to installation and soldering.
- Discard O-rings that come with the condensing unit. Oil and install new O-rings supplied in kit.
- Clean all threads on ORS fittings prior to installation.
- Apply refrigerant oil to the O-rings only. **DO NOT APPLY OIL TO THE ORS FITTING THREADS!**
- Each zone needs to have a separate suction line with a check valve installed as close as possible to condensing unit.
Note: Remove internal components of valves before soldering and use 35% silver solder.
- When tightening ORS tubing connections, always use a backup wrench to hold the backside of the ORS fitting to prevent the refrigeration tube from twisting.
- Torque ORS fittings on the condenser as shown in the table below.
- Insulation should be added to all segments of suction and hot gas tubes.
- Secure all tubing every 609.6 mm (24.00 in.) with provided clamps.

Specifications for ORS Fittings				
Tube	Size	Thread	Torque	O-Ring Gaskets P/N
Liquid	3/8 in.	11/16-16	16-17 ft-lb	331015
Hot Gas	1/2 in.	13/16-16	32-35 ft-lb	330566
Suction	1-1/8 in.	1-11/16-12	93-102 ft-lb	331777

Figure 46. Condensing Unit Connections Shown

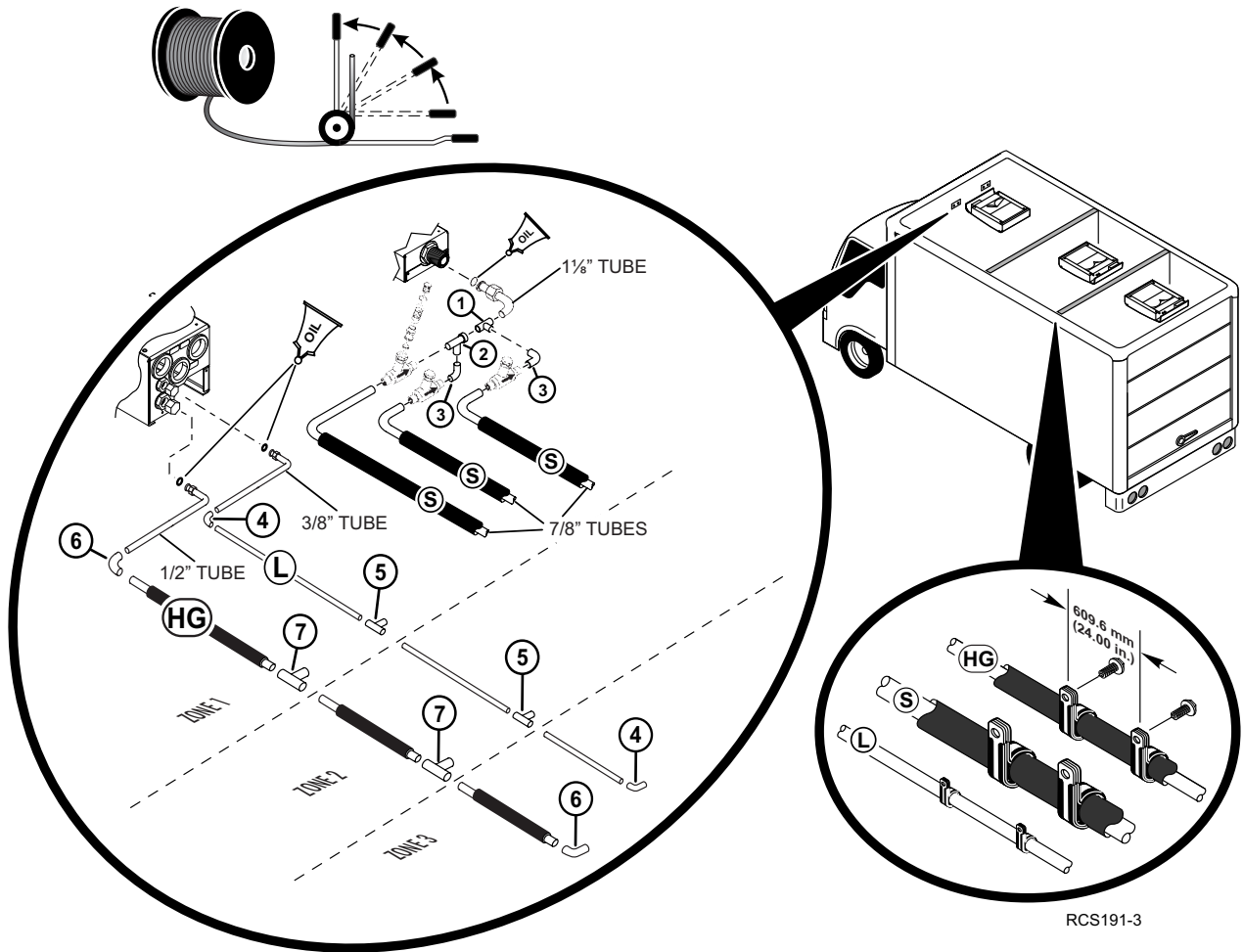

The copper fittings in the illustration are shown in the table below.

Item	Description	P/N
#1	Tee 1-1/8 in. x 1-1/8 in. x 7/8 in.	559517
#2	Tee 1-1/8 in. x 7/8 in. x 7/8 in.	558968
#3	90° Elbow 7/8 in. x 7/8 in.	553326
#4	90° Elbow 3/8 in. x 3/8 in.	552876
#5	Tee 3/8 in. x 3/8 in. x 3/8 in.	553251
#6	90° Elbow 1/2 in. x 1/2 in.	558812
#7	Tee 1/2 in. x 1/2 in. x 1/2 in.	552296



Connections at Evaporator

Figure 47. Evaporator Connections

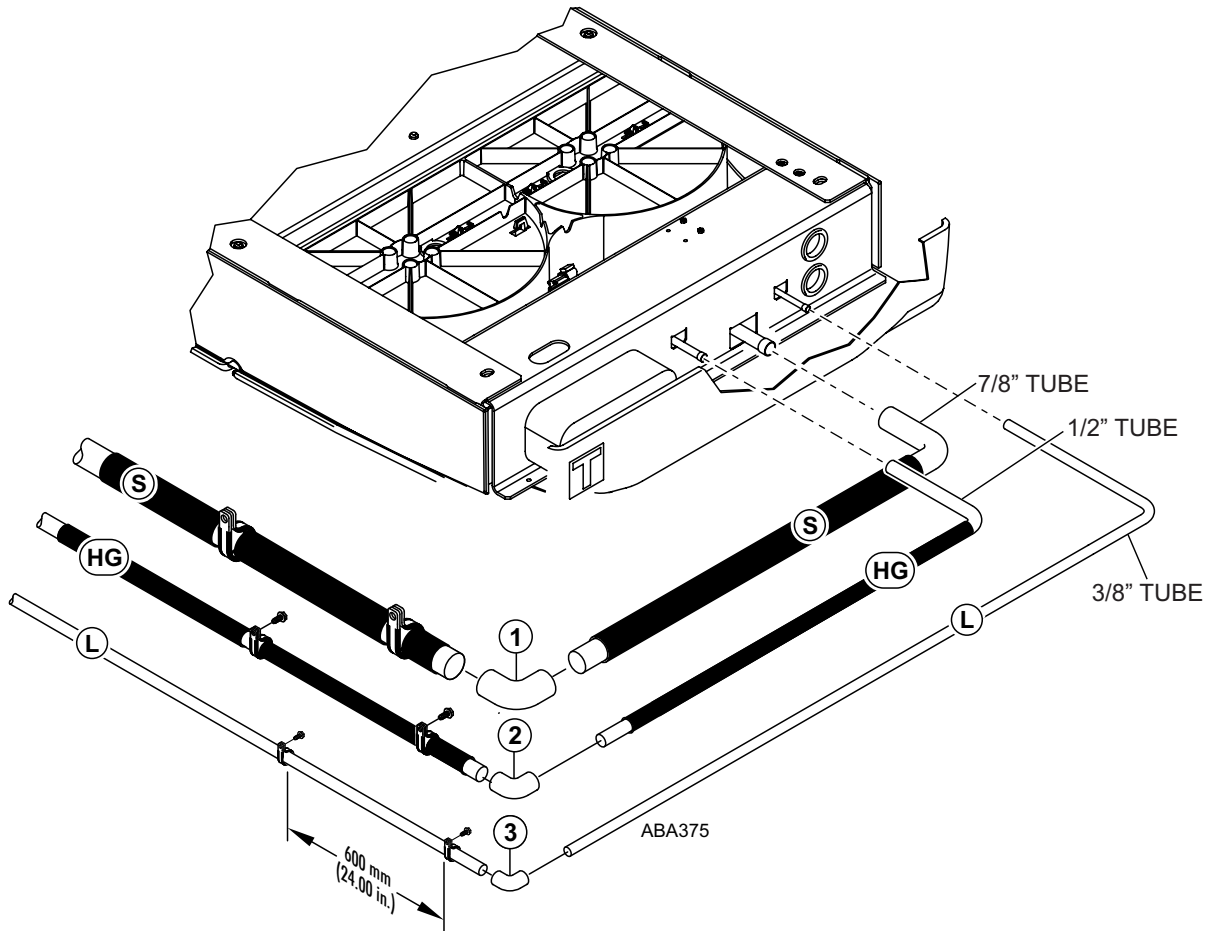

The copper fittings in the illustration are shown in the table below.

Item	Description	P/N
#1	90° Elbow 7/8 in. x 7/8 in.	553326
#2	90° Elbow 1/2 in. x 1/2 in.	558812
#3	90° Elbow 3/8 in. x 3/8 in.	552876

Wire Connections

S-2 or S-3 Installations

Important: Safety precautions must be followed. Refer to **Unit Installation Hazards** located in the **Safety Precautions** section of this manual before proceeding.

Important: For the system to operate correctly:

- All **Zone One** harnesses at the condensing unit must be connected only to the **Zone One** evaporator.
- All **Zone Two** harnesses at the condensing unit must be connected only to the **Zone Two** evaporator.

Note: Superlube (203-524 or equivalent) must be applied to all electrical connections.

Refer to the illustration on the following page.

1. **EVAPORATOR HARNESSSES** - Attach the 6 pin connectors to the correct (Zone One or Two) mating connectors at the back of condensing unit (**Detail A**).
2. Attach the 2 pin connectors (FM1, CH1 and FM2, CH) to the correct (Zone One or Two) mating connectors at the back of the condensing unit (**Detail A**).

ZONE ONE	ZONE TWO
FM1A, CHF-1 FM1B, CHF-2	FM2A, CHF-3 FM2B, CHF-4

3. Route each harness to the terminal block of the correct (Zone One or Two) evaporator.
 - a. Cut wires (HGS, SLS, LLS, FM1, FM2, SC, DH, CH1 and CH) to length, strip 7 mm (0.25 in.) from ends and attach ring terminals onto CH1 and CH wires and forked terminals on all others.
 - b. Connect wires (HGS, SLS, LLS, DH, FM1, FM2, and SC) to each terminal block (**Detail B**).
 - c. Connect wires (CH1 and CH) to the ground stud of each evaporator (**Detail B**).
4. Attach the sensor connectors to the mating connectors located in the correct (Zone One or Two) evaporator (**Detail C**).
 - a. Coil Temperature Sensor (CTN, CTP)
 - b. Discharge Air Temperature Sensor (DTN, DTP)
 - c. Return Air Temperature Sensor (RTN, RTP)

Important: The gold terminal pins supplied in the installation kit must be used if the sensor harnesses are cut to length.

5. Secure all harnesses with adequate clamps or band wraps approximately every 600 mm (24 in.).

Figure 48. Wire Connections to S-2 or S-3 Evaporators

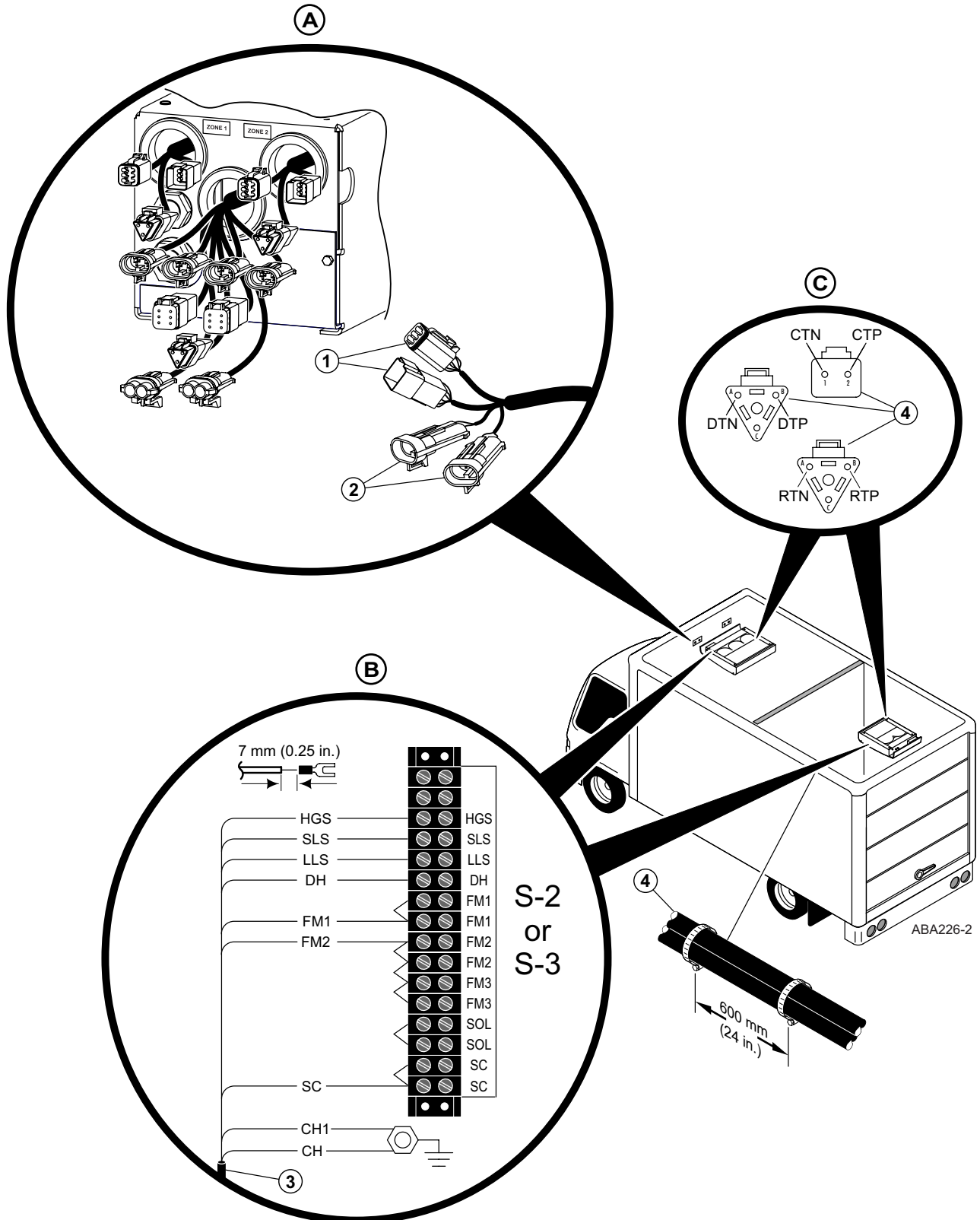

S-2 + S-2 Installations

Important: Safety precautions must be followed. Refer to **Unit Installation Hazards** located in the **Safety Precautions** section of this manual before proceeding.

Important: For the system to operate correctly:

- All **Zone One** harnesses at the condensing unit must be connected only to the **Zone One** evaporator.
- All **Zone Two** harnesses at the condensing unit must be connected only to the **Zone Two** evaporator.

Note: Superlube (203-524 or equivalent) must be applied to all electrical connections.

Refer to the illustration on the following page.

1. **EVAPORATOR HARNESSSES** - Attach the 6 pin connectors to the correct (Zone One or Two) mating connectors at the back of condensing unit (**Detail A**).
2. Attach the 2 pin connectors (FM1, CH1 and FM2, CH) to the correct (Zone One or Two) mating connectors at the back of the condensing unit (**Detail A**).

ZONE ONE	ZONE TWO
FM1A, CHF-1 FM1B, CHF-2	FM2A, CHF-3 FM2B, CHF-4

3. Route each harness to terminal block of correct (Zone One or Two) evaporator.
 - a. Cut wires (HGS, SLS, LLS, FM1, FM2, SC, DH, CH1 and CH) to length, strip 7 mm (0.25 in.) from ends and attach ring terminals onto CH1 and CH wires and forked terminals on all others.
 - b. Connect wires (HGS, SLS, LLS, DH, FM1, FM2, and SC) to each terminal block (**Detail B**).
 - c. Connect wires (CH1 and CH) to the ground stud of each evaporator (**Detail B**).
4. Attach the sensor connectors to the mating connectors located in the correct (Zone One or Two) evaporator (**Detail C**)
 - a. Coil Temperature Sensor (CTN, CTP)
 - b. Discharge Air Temperature Sensor (DTN, DTP)
 - c. Return Air Temperature Sensor (RTN, RTP)

Important: Gold terminal pins supplied in installation kit must be used if sensor harnesses are cut to length.

5. Connect the **INTERCONNECT HARNESS** to the first evaporator (of two) in the same zone (**Detail B**).
 - a. Connect wires (FMA-2, FMB-2, HGS, LLS, SLS, SC and DH) with forked terminals to terminal block on first evaporator.
 - b. Connect (CH) wire with ring terminal to ground stud of evaporator.
6. Route the **INTERCONNECT HARNESS** to the second evaporator (of two) in the same zone (**Detail B**).
 - a. Cut wires ((FMA-2, FMB-2, HGS, LLS, SLS, SC, DH and CH) to length, strip 7 mm (0.25 in.) from the ends and attach a ring terminal onto the CH wire and forked terminals on all others.
 - b. Connect wires (FMA-2, FMB-2, HGS, LLS, SLS, SC and DH) to terminal block on evaporator.
 - c. Connect wire (CH) to ground stud of evaporator.
7. Secure all harnesses with adequate clamps or ties approximately every 600 mm (24 in.).

Figure 49. Wire Connections to S-2 + S-2 Evaporators

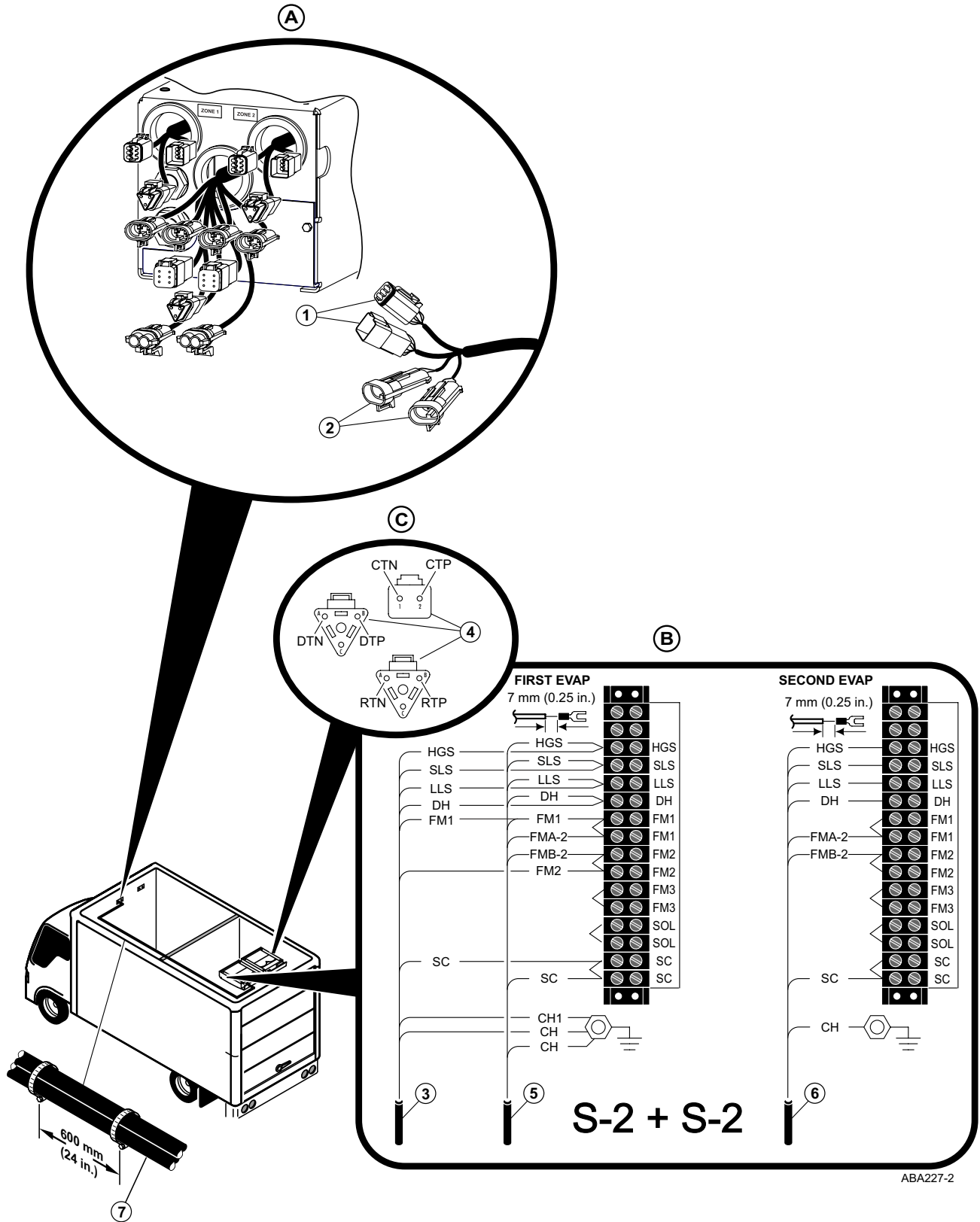

Three Zone Installations

Important: Safety precautions must be followed. Refer to **Unit Installation Hazards** located in the **Safety Precautions** section of this manual before proceeding.

Important: For the system to operate correctly:

- All **Zone One** harnesses at the condensing unit must be connected only to the **Zone One** evaporator.
- All **Zone Two** harnesses at the condensing unit must be connected only to the **Zone Two** evaporator.
- All **Zone Three** harnesses at the condensing unit must be connected only to the **Zone Three** evaporator.

Note: Superlube (203-524 or equivalent) must be applied to all electrical connections.

Refer to the illustration on the following page.

1. **EVAPORATOR HARNESSSES** - Attach the 6 pin connectors to the correct (Zone One, Two or Three) mating connectors at the back of condensing unit (**Detail A**).
2. Attach the 2 pin connectors (FM1, CH1 and FM2, CH) to the correct (Zone One, Two or Three) mating connectors at the back of the condensing unit (**Detail A**).

ZONE ONE	ZONE TWO	ZONE THREE
FM1A, CHF-1 FM1B, CHF-2	FM2A, CHF-3 FM2B, CHF-4	FM3A, CHF-5 FM3B, CHF-6

3. Route each harness to terminal block of correct (Zone One, Two or Three) evaporator.
 - a. Cut wires (HGS, SLS, LLS, FM1, FM2, SC, DH, CH1 and CH) to length, strip 7 mm (0.25 in.) from ends and attach ring terminals onto CH1 and CH wires and forked terminals on all others.
 - b. Connect wires (HGS, SLS, LLS, DH, FM1, FM2, and SC) to each terminal block (**Detail B**).
 - c. Connect wires (CH1 and CH) to the ground stud of each evaporator (**Detail B**).
4. Attach the sensor connectors to the mating connectors located in the correct (Zone One, Two or Three) evaporator (**Detail C**)
 - a. Coil Temperature Sensor (CTN, CTP)
 - b. Discharge Air Temperature Sensor (DTN, DTP)
 - c. Return Air Temperature Sensor (RTN, RTP)

Important: Gold terminal pins supplied in installation kit must be used if sensor harnesses are cut to length.

5. Secure all harnesses with adequate clamps or ties approximately every 600 mm (24 in.).

Figure 50. Wire Connections for Three Zone Systems

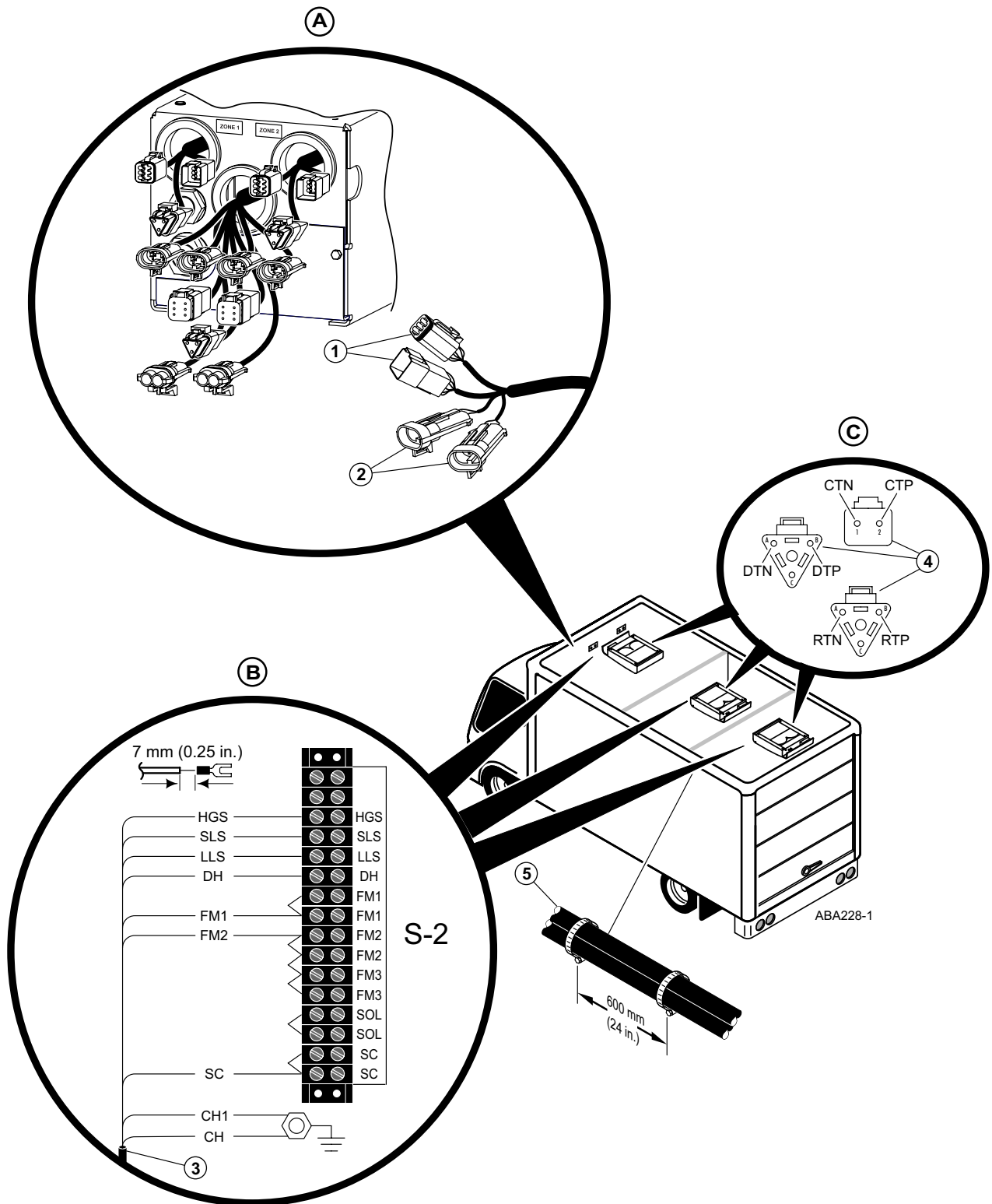

Evaporator Drain Hose Installation

Important: Safety precautions must be followed. Refer to **Unit Installation Hazards** located in the **Safety Precautions** section of this manual before proceeding.

Drain Hose Resistance Wires

⚠ DANGER

Fire Hazard!

Never bundle evaporator drain hose resistance wires together as the amount of heat produced could result in a fire!

Refer to “[Drain Hose Resistance Wire Installation Guide](#),” p. 50 for complete details.

Important: DO NOT CUT RESISTANCE WIRES!

Drain Hose Requirements

For the condensate drain system to operate correctly, the drain hose(s) must:

- be properly seated on tube fittings before mounting to evaporator.
- slope down continuously from the evaporator to the wall drains with no kinks, droops or leaks.

S-2 and S-3 Applications

1. Route each resistance wire from evaporator through plastic drain hose and insert entire length of one resistance wire into each wall drain tube.
2. Connect single drain hose to wall drain tube using a short piece of plastic drain hose and clamp as required.
3. Replace drain T-fitting with elbow fitting.

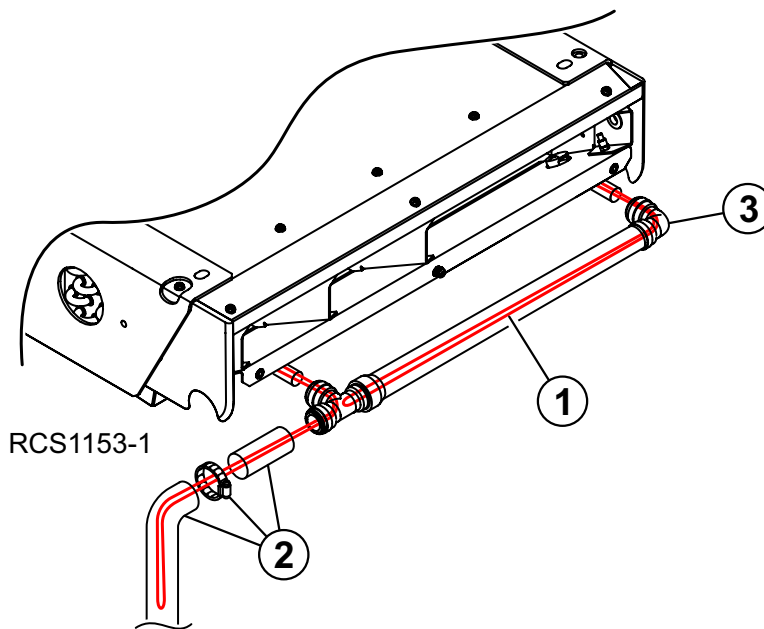



Evaporator Drain Hose Installation

S-2 + S-2 Applications

4. Route each resistance wire from evaporator through plastic drain hose and insert entire length of one resistance wire into each wall drain tube.
5. Connect each drain hose to each wall drain tube using a short piece of plastic drain hose and clamps as required.

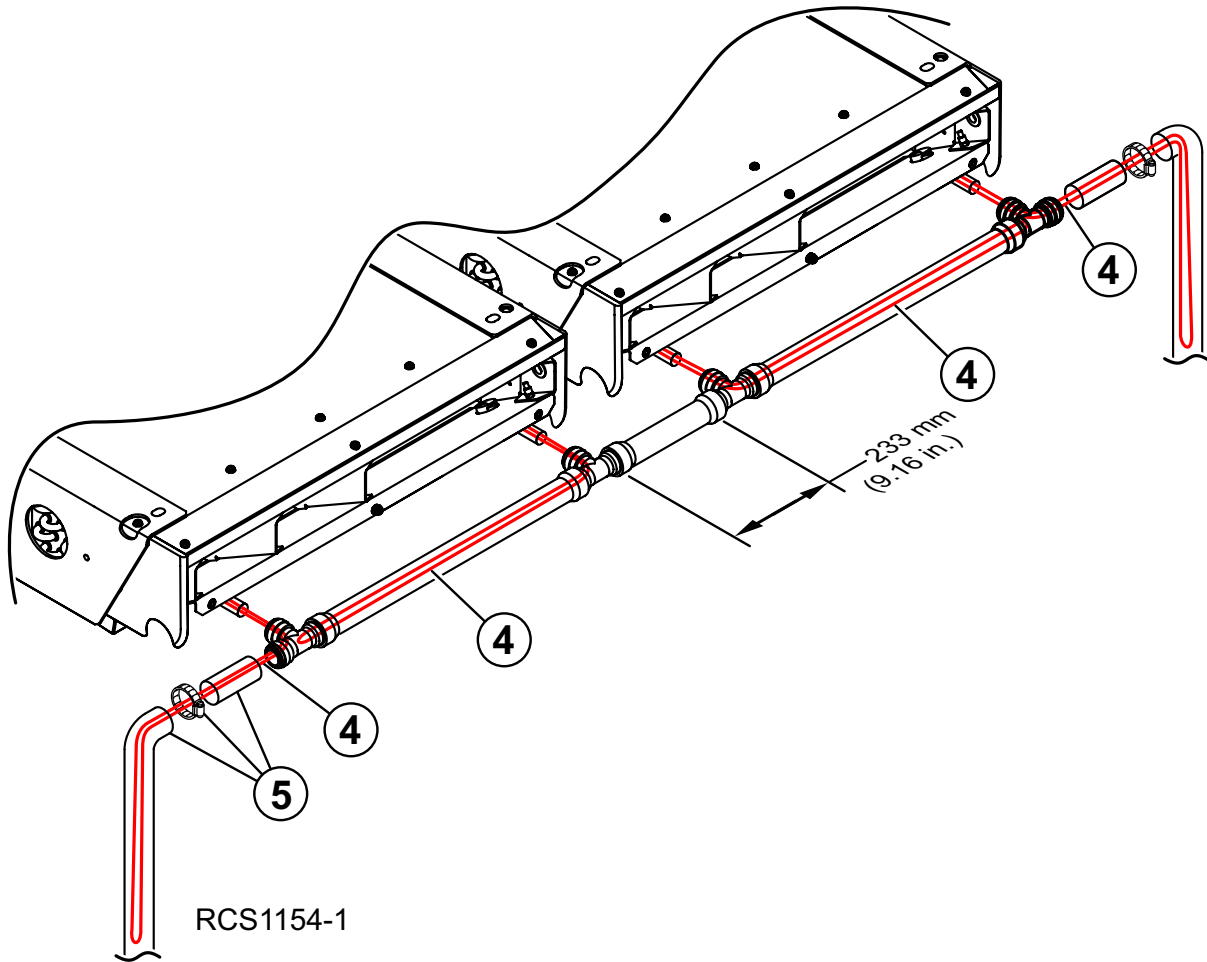

Wall Mounted Tube Applications

Insert entire length of the resistance wire into the wall drain tube and connect plastic drain hose from evaporator. Confirm resistance wire is not balled up in wall drain tube.

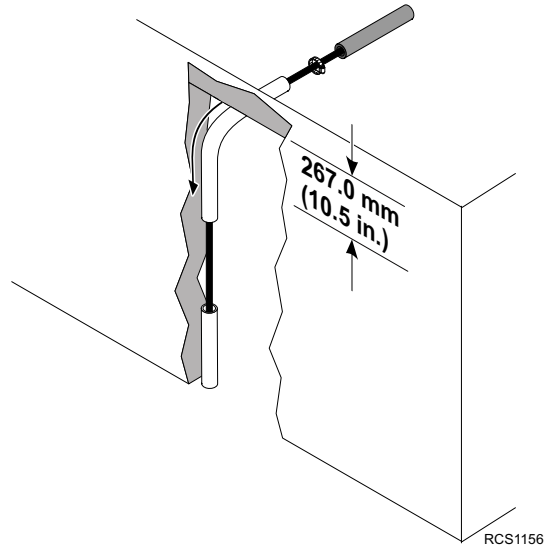
**Wall Mounted Channel Applications**

Insert entire length of resistance wire into plastic drain hose. Feed plastic drain hose down through wall channel until it exits the bottom of truck. Confirm resistance wire is not balled up in wall drain channel.

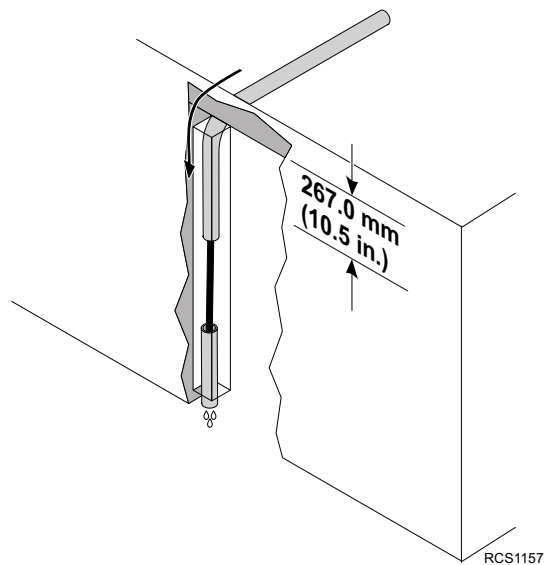

Evaporator Drain Hose Installation

Optional Drain Hose Support

The optional drain hose support bracket is recommended when evaporator drain tube cannot be directly routed into a wall drain.

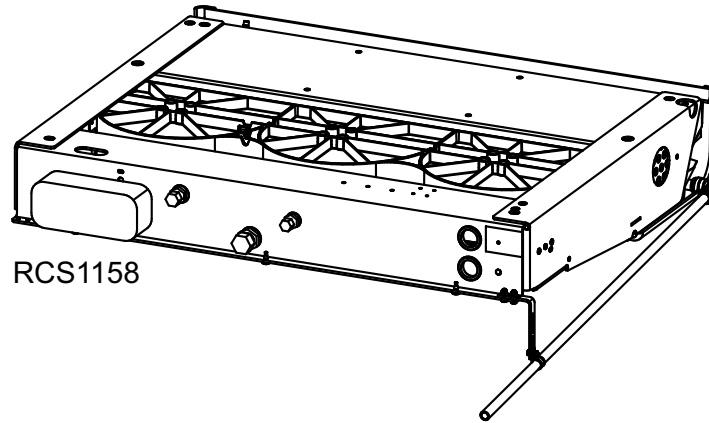

Front Drain Hose Applications

Install drain T-fittings to allow drain tube to exit the front of evaporator, insert entire length of one resistance wire into each drain hose, and route hose out front of cover to wall drain.

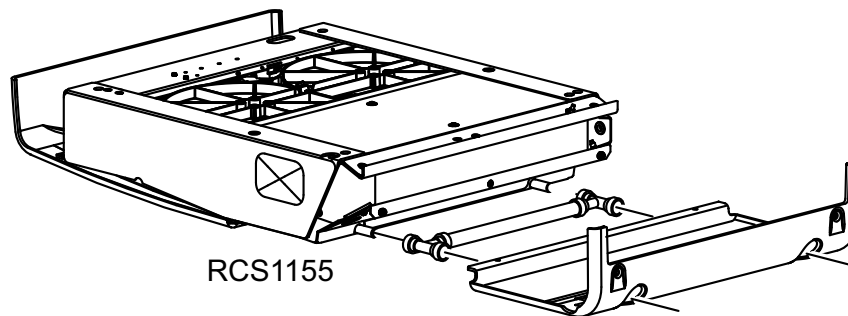

Installing Cap Plugs and Evaporator Covers

Important: Cap plugs are provided to plug the two evaporator mounting access holes located directly above the drain pan. These plugs must be installed to prevent water in the drain pan from spilling out of these holes and into the cargo area.

1. Install **CAP PLUGS** - 2 per evaporator.
2. Install **SIDE COVERS** onto evaporator and secure with screws.
3. Install **FRONT COVER** into support channel of evaporator and secure with screws.
4. Install **REAR COVER** into support channel of evaporator and secure with screws.

Figure 51. Install Cap Plugs and Evaporator Covers

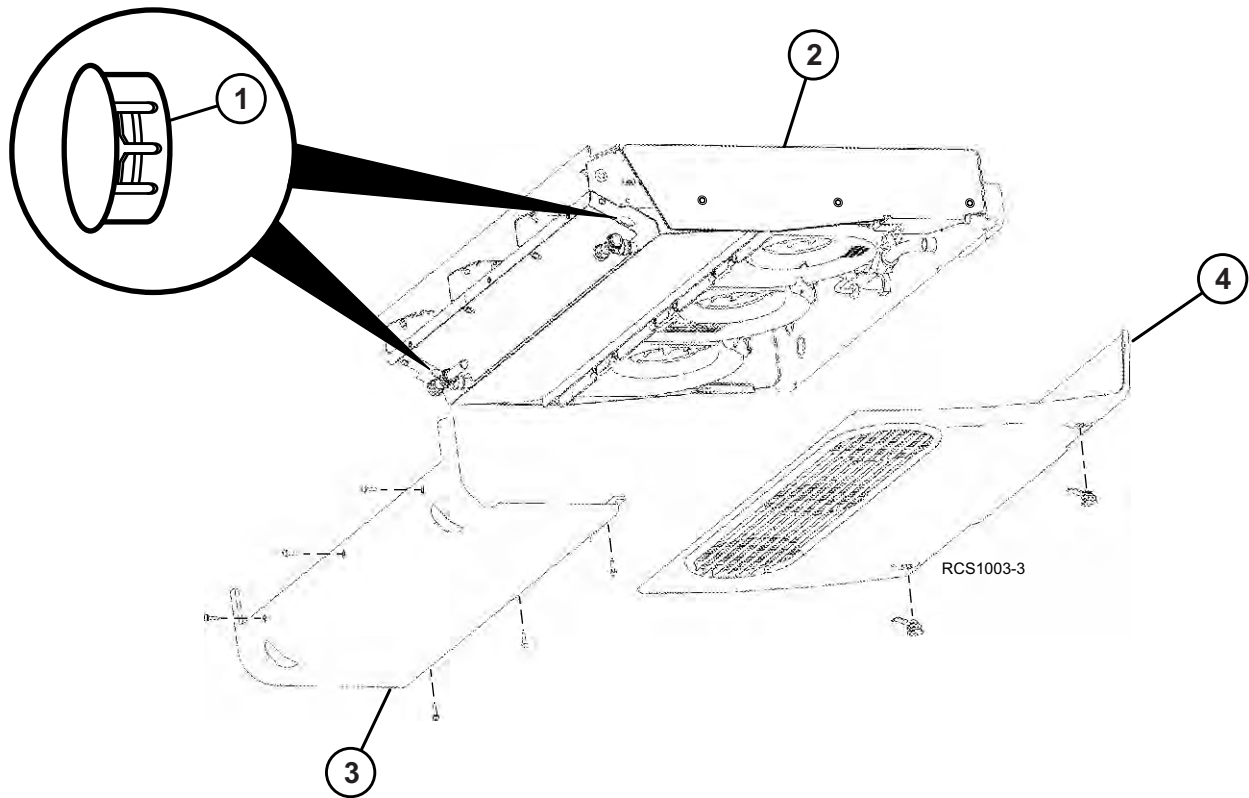

Battery Connections

Important: Safety precautions must be followed. Refer to **Battery Installation and Cable Routing Hazards** located in the **Safety Precautions** section of this manual before proceeding.

Note: Thermo King units are designed for one 12 volt, group 31 battery. The battery must be suitable for deep cycling, heavy duty, and rated with a minimum of 95 amp/hr.

Important: Battery cables must be routed in split loom protective sleeving with no kinks or sharp bends.

Refer to the illustration on the following page for battery cable and fuse installation details.

Positive Cable Installation

1. At the unit, locate the large black cable marked **POS+**.
 - a. Route cable to battery, cut to proper length and add supplied battery cable lug.
 - b. **DO NOT** connect to battery yet.

In-Line Fuse Installation

2. FOLLOW THE INSTALLATION INSTRUCTIONS (TK 56239).

Fuel Pump Harness Installation

3. Route and connect the fuel pump harness to the fuel pump.

Negative Cable Installation

4. At the unit, locate the large black cable marked **NEG**.
 - a. Route cable to battery, cut to proper length and add battery lug from installation kit.
 - b. Connect cable to the **NEGATIVE** terminal of battery (**Detail B**).
5. All harnesses and battery cables should be neatly routed and secured with provided clamps.
6. Install battery box cover securely (if applicable).

Nameplate Installation

7. Attach supplied nameplate near the battery the unit is connected to (vehicle's battery or battery box).

Figure 52. Battery and Fuel Pump Connections Shown

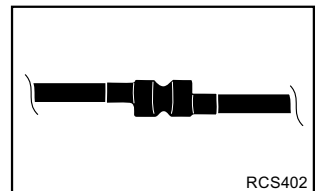
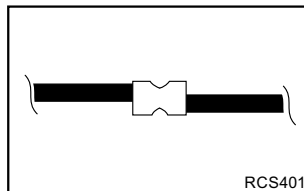
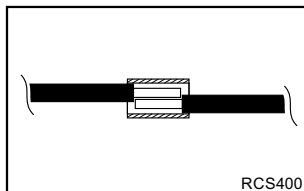
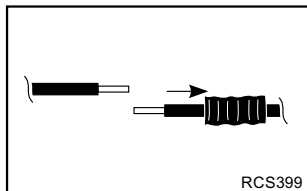
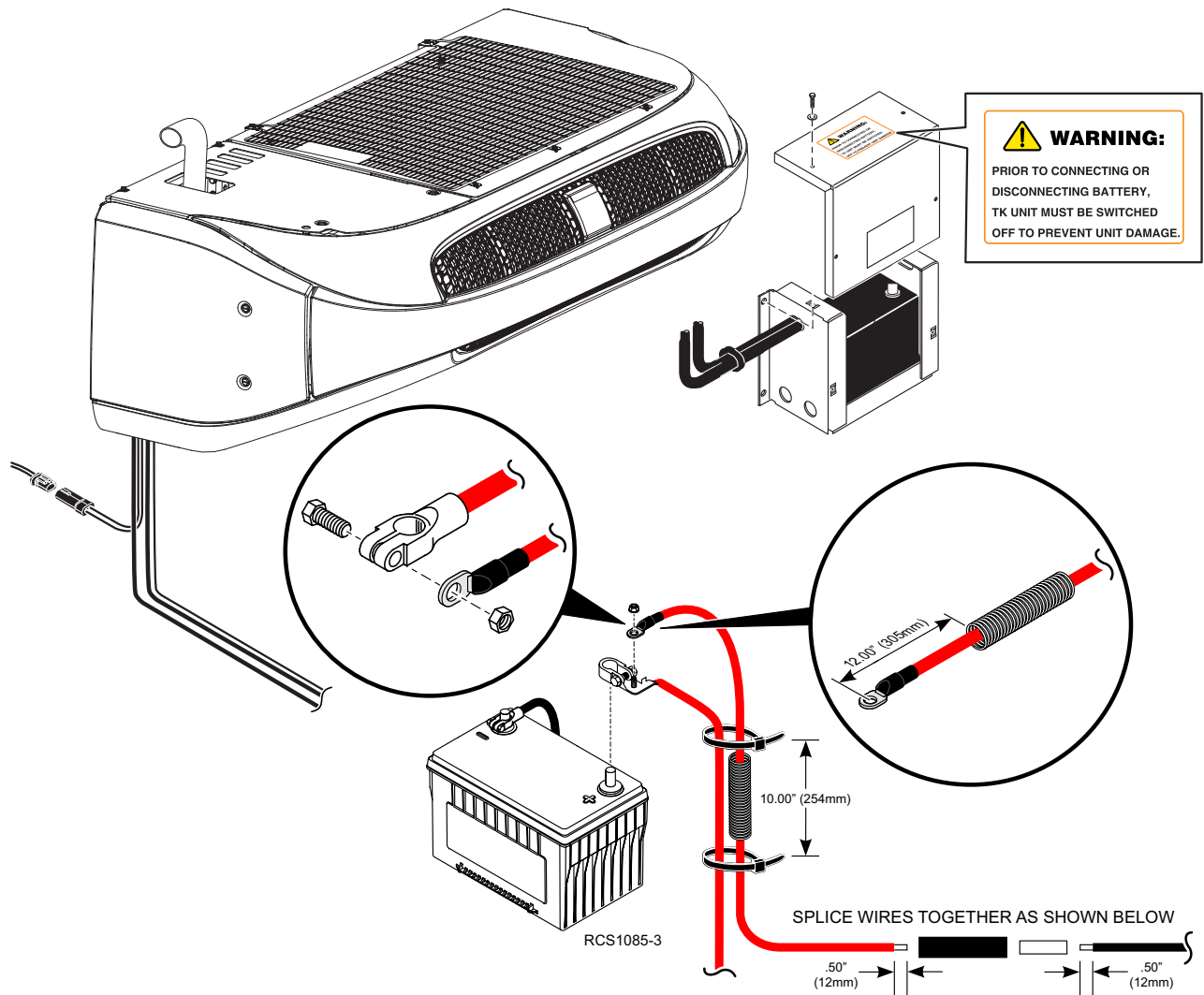

Auxiliary Electrical Accessories

Thermo King does not recommend adding any auxiliary electrical accessories to the electrical system of a T-590, T-690, T-890 or T-1090 series units equipped with SR-3 controllers and Tier 4 engines unless approved by Thermo King.

TrackKing (OPTION)

Units equipped with the factory installed TrackKing option requires additional procedures to activate the system. See TrackKing Cellular Installation Manual TK 56186 for activation procedures.

System Leak Check Procedures

Set-up Unit

Place microprocessor in Evacuation Mode to leak check, evacuate and charge unit. With the SPECTRUM microprocessor in the evacuation mode all solenoid valves in the refrigeration system are open. This allows the refrigeration system to be properly evacuated.

Note: Refer to appropriate Operation & Diagnosis Manual for complete information about the microprocessor.

Use the following procedure to place the SPECTRUM microprocessor in the Evacuation Mode:

- a. Connect unit battery and attach a battery charger to the battery. The battery must be capable of at least 20 amperes output. This will maintain the charge level of the battery during the time required to leak check, evacuate and charge the unit.
- b. Turn the unit on. (DO NOT allow the diesel engine or electric motor to start).
- c. From the main screen on the HMI, enter the Menu screen by pushing MENU.
- d. At the first Operator Menu screen that appears; either the Language Display or the Alarms Display, press and hold the unlabeled soft key and the EXIT key for 5 seconds.
- e. The Maintenance Hourmeter Menu will appear. Press the NEXT key as required to show the Evacuation Mode Menu.
- f. When the Evacuation Mode Menu is shown press the SELECT key.
- g. The unit will stay in Evacuation Mode until the battery voltage falls below a minimum voltage or the EXIT key is pressed.

Leak Check the System

Note: Refer to *Diagnosing Thermo King Refrigeration Systems (TK-5984-10)* for leak detection procedures.

Refer to the illustration below.

1. Connect leak test gas (R-404A) supply to center hose of gauge manifold.
2. Attach gauge manifold hoses to the suction service valve and the discharge service port.
3. Pressurize the system with leak test gas. If desired, system pressure may be boosted using nitrogen gas.
4. Check connections made during installation for leaks using electronic leak detector and or soap bubbles.
5. Recover test gas to repair leaks. System must be vented while repairing solder joint leaks. Pressurize the system and check again after a leak has been repaired.
6. If no leaks are found recover test gas to 0 psig.

Figure 53. Leak Check the System

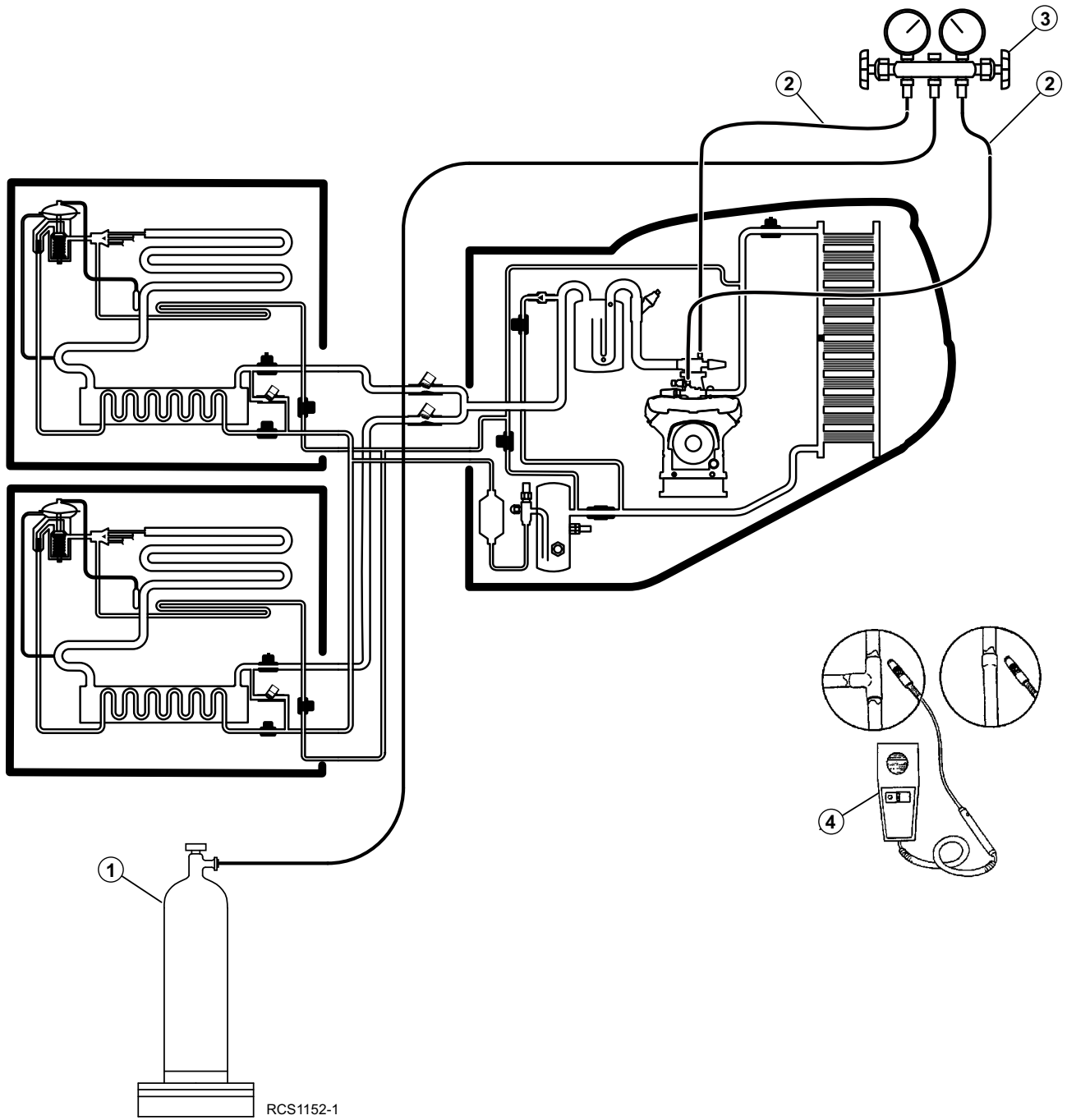

System Evacuation

Important: Do not evacuate unit until it is leak free. Unit with less than a full refrigerant charge should be leak checked and all leaks must be repaired.

Note: Use of Thermo King Evacuation Station (P/N 2040725) and Evacuation Station Operation and Field Application Instructions (TK-40612-2) is required.

Refer to the illustration on the following page.

1. Recover any refrigerant to 0 psig. (Regulations may require recovery machine to pull system pressure lower than 0 psig).
2. Before connecting refrigerant hoses to unit, close valves V1 and V4 on the evacuation system and turn micron gauge ON.
3. Back seat suction and receiver tank service valves. Attach evacuation hoses to these two valves as well as the discharge service port (check condition of hose seals).
4. With service valves fully back seated, turn evacuation pump ON and open valve V1 (V2 and V3 should also be open). Micron gauge should move to a deep vacuum.
5. Open valve V4. Micron reading will rise. If micron gauge returns to reading less than 500 microns, proceed to step 6. If micron reading remains high, a leak exists at hose fittings or packing glands. Locate and correct problem. Packing glands that do not seal can be corrected by installing valve stem covers (see step 6).
6. If step 5 was successful, close valve V2 to isolate thermistor. Open suction, discharge and receiver service valves to port. Install brass and steel valve stem covers (with sealing washers) on service valves and tighten. Let vacuum pump continue to operate
7. After 5 minutes of evacuation, open valve V2 to access thermistor and micron gauge. Micron reading now shows system pressure.
8. Evacuate system to 500 microns or lowest achievable level between 500 and 1000 microns. Multi-Temp units should be evacuated for an additional hour once 500 microns is reached.
9. When acceptable micron level is achieved (500 to 1000 microns plus on hour for Multi-Temp units), close valve V1 to isolate pump. Turn pump OFF.
10. Observe reading on micron gauge after 5 minutes have elapsed. If vacuum level exceeds 2000 microns after 5 minutes, leak is present or additional evacuation time is required.
11. If vacuum level is acceptable, start pump and open valve V1 to evacuate pressure rise (5 minutes).
12. With vacuum pump running, back seat suction service valve. Observe micron gauge and continue to operate vacuum pump until an acceptable micron level is achieved.
13. Close valve V1 and stop pump. Observe micron gauge to confirm that system remains in a deep vacuum. Close valve V4. Unit is ready to charge.

Figure 54. System Evacuation Shown

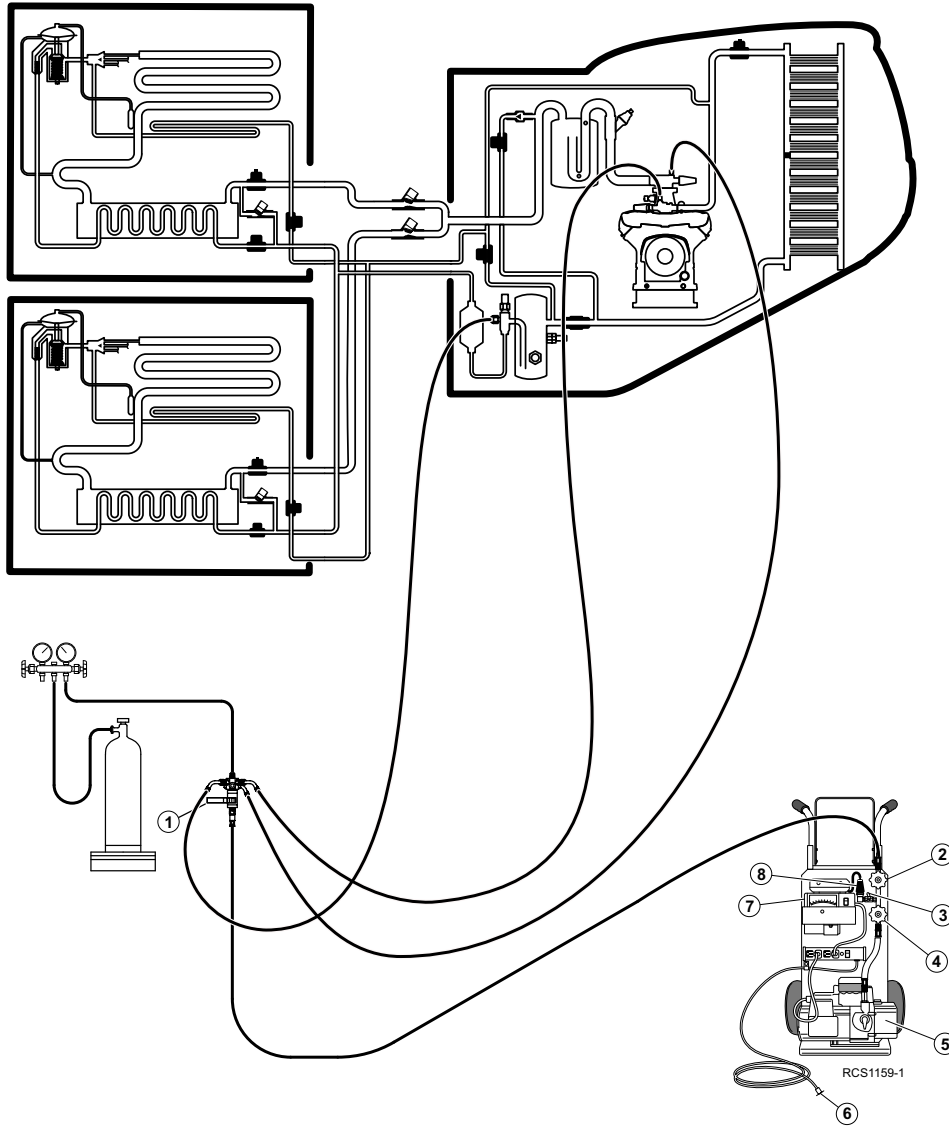

Legend for Evacuation and Charging Diagram			
1.	V-4	5.	Two Stage Vacuum Pump
2.	V-3	6.	To AC Power
3.	V-2	7.	Micron Gauge
4.	V-1	8.	Thermistor

System Charging

Important: Unit must be leak checked and fully evacuated before charging.

1. Install a gauge manifold. Attach the low side gauge to the service port on the suction service valve. Attach the high side gauge to the service port on the discharge line near the condenser.
2. Close the valves on the gauge manifold.
3. Mid seat the compressor suction service valve.
4. Connect a refrigerant supply to the gauge manifold service line and purge the line.
5. Set the refrigerant supply bottle to liquid and open the hand valve.
6. Open the high side gauge manifold valve. Add a partial charge of 10 lbs. (4.5 kg) of liquid refrigerant and close the high side gauge manifold valve. The remainder of the charge will be added as a liquid through the low side gauge manifold valve.
7. Set both zones to HIGH SPEED COOL through the HMI Service Test Mode.
8. Observe the suction pressure and slowly open the low side gauge manifold valve to allow liquid refrigerant to flow into the compressor suction service valve
9. Control the liquid flow so the suction pressure increases approximately 20 psi (138 kPa).
10. Maintain a discharge pressure of at least 300 psig (2068 kPa) while adding refrigerant.
11. Close the low side gauge manifold valve when the receiver sight glass shows 1/2 to 3/4 full.
12. Establish a return air temperature of 0 F (-18 C), a suction pressure of 13 to 18 psig (90 to 124 kPa), and a discharge pressure of 300 psig (2068 kPa).
13. Check the receiver tank sight glass. The refrigerant level should remain between 1/2 and 3/4 full over a period of no less than 5 minutes.
14. Use a paint pen and mark the final amount of refrigerant charge on or near the condensing unit serial plate for future reference.

Figure 55. System Charging Shown

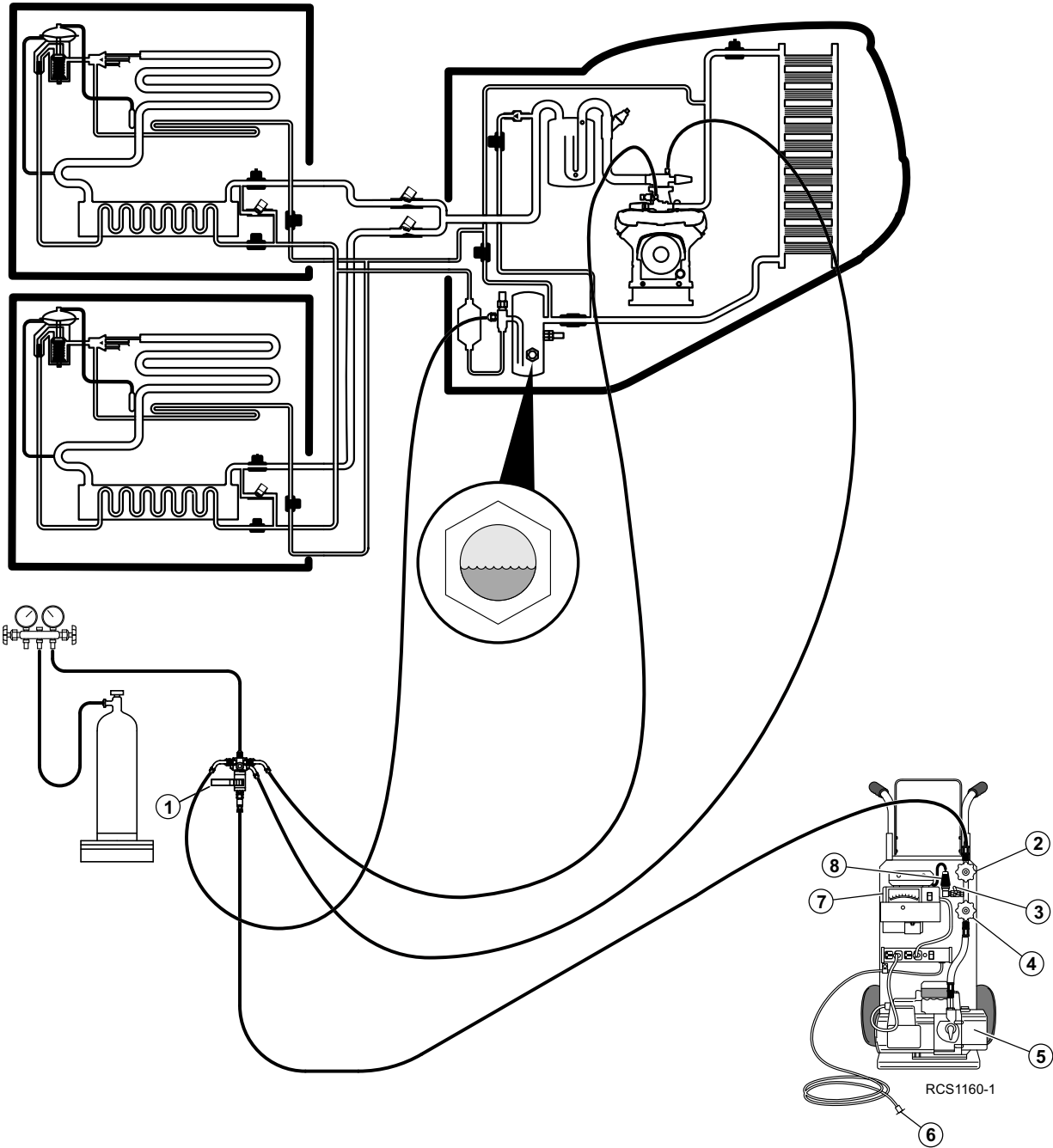

Legend for Evacuation and Charging Diagram			
1.	V-4	5.	Two Stage Vacuum Pump
2.	V-3	6.	To AC Power
3.	V-2	7.	Micron Gauge
4.	V-1	8.	Thermistor

Commissioning and PDI Forms

Commissioning Form Overview

All self-powered truck units come with the Commissioning Form (TK 56640) included in the documents package. This form is also available online at Thermo King ReqDirect. By completing the Commissioning Form, the **installer** confirms the installation was done per Thermo King's Installation Manual and the unit operates as it should. Commissioning Forms should be completed for all unit installations and retained by the **installer**.

FORMS ARE LOCATED ON NEXT THREE PAGES

Figure 56. Page 1 of 3 Shown



Self-Powered Truck Installation and Commissioning Form

Section 1 - Equipment Information			
Unit Serial No.	Model:		
Product: Self-Powered Truck	Date in Service:		
Model:	Truck No.:		
Install Date:	Break-in Beginning Hourmeter:		
VIN No.	Break-in Ending Hourmeter:		
OEM:			
Section 2 – Serialized Component Information			
#1 Remote Evap Serial No.:	Add'l Component Part No. / Desc.:		
#2 Remote Evap Serial No.:	Add'l Component Part No. / Desc.:		
#3 Remote Evap Serial No.:	Add'l Component Part No. / Desc.:		
Add'l Component Part No. / Desc.:	Add'l Component Part No. / Desc.:		
Section 3 – Unit Installed By			
Installer Name:			
Address:	City:	State:	Zip Code:
Section 4 – Company Registering Unit			
Company Name:			
Address:	City:	State:	Zip Code:
Section 5 – Unit Owned By			
Company Name:			
Address:	City:	State:	Zip Code:
Section 6 – Unit Operated By			
Company Name:			
Address:	City:	State:	Zip Code:
Section 7 - Statement			
Important: This form certifies that the unit has been delivered in satisfactory operating condition. <u>The date of service should not exceed 90 days from date of installation.</u>			
Delivering Co. Signature:		End User Signature:	

Further information can be found in the Self-Powered Single Temp Truck Installation Manual TK#56700 and the Multi-Temp Truck Installation Manual TK#56701 available through Thermo King Publications.

Figure 57. Page 2 of 3 Shown**UNIT CHECK LIST**

- Visually inspect the unit for transit and handling damage, file claim with delivery carrier.
- Install the unit as outlined in the Thermo King Self-Powered Truck Installation Manual.
- If the unit has a separate fuel tank, add 20 gallons (minimum) of ultra-low sulfur diesel fuel to the tank.

BEFORE STARTING THE UNIT

- Check battery and battery cable installation.
- Inspect fuel line routing checking for rubbing, chaffing or laying on hot surfaces.
- Visually inspect the unit for the following: loose or improperly fitting bolts, brackets, hardware, hose connections, and hose routing.
- Inspect all wiring connections and routing.
- Check defrost drain hoses and drain kazoos.
- Check unit mounting hardware for tightness.
- Check compressor and engine mounts.
- Install refrigeration gauge manifold. (Multi-Temp units only)
- Check engine oil level.
- Check condenser and evaporator section for cleanliness and signs of refrigerant leaks.
- Check belt tensions.

MULTI-TEMP UNITS (REMOTE EVAPORATORS)

- Check evaporator(s) sections for cleanliness.
- Leak test interconnecting tubing.
- Check for damage, loose or missing bolts, and hardware on remote evaporator(s).
- Check for proper installation of drain hoses, drain kazoos and drain tube heater wires.
- Check for properly routed refrigerant tubing and wiring harnesses for remote evaporator(s). Check for properly routed harnesses for remote controller.
- Check for proper installation of remote evaporator guards if equipped.
- Check remote harness wiring connections at pass-through.
- Check wiring, connections, and terminals in the remote evaporator(s).
- Check compartment bulk head(s) for proper fit if equipped.

START AND RUN UNIT (On Multi-Temp units, start only the host unit)

- Check for proper coolant temperature, oil, fuel, or coolant leaks.
- Check alternator output.
- Cycle the unit and ensure the unit functions in the correct modes and the mode indicators are working.
- Confirm engine speeds at high and low speed per maintenance manual.
- Set for continuous run with setpoint at 32 F (0 C) and run the unit to 32 F (0 C).
- Observe and record refrigerant operating pressures in relation to ambient and box temperatures.
- Verify the readings above are correct for the conditions.
- Run unit for 30 minutes at 32 F (0 C). During this period check for correct cycling.
- Allow unit to run and check refrigerant level at a 0 F box temperature (while running in high speed cool per truck installation manual). If unit is a multi-temp, ensure all zones are in cool mode when this check is performed.
- Visually check sight glass.
- Check for proper refrigerant level.

MULTI-TEMP UNITS

- Install the compartment bulk head(s) if equipped.
- Check for correct rotation of remote evaporator fans.
- Check for correct cycling and operation of remote evaporator fans.
- Check the charge per multi-temp unit procedures.



Figure 58. Page 3 of 3 Shown

ALL UNITS

- Initiate and check defrost operation and termination. Check operation and adjustment of damper door and remote fans. Each zone on multi-temp units must be checked for proper operation.
- Set the unit for Cycle Sentry Operation.
- Check for proper operation of all door switches if equipped.
- Remove the compartment bulk head(s) if equipped.
- Set the unit for continuous run. Choose a setpoint opposite of ambient temperature. Continue to run the unit with the cargo box doors open. Operate the unit until 10 (minimum of 6) hours are shown on the engine run time hourmeter to verify complete break-in. Refer to TT692-1 for additional break-in information.
- Run Pre-Trip Test.

SMARTPOWER (ELECTRIC STANDBY) OPERATIONAL CHECKS IF EQUIPPED

- Test AC electrical contacts and connections by connecting to AC power and running.
- Check for correct electric motor rotation.
- Check compressor clutch operation.
- Adjust setpoint and check for correct modes of operation.
- Power source not available to test AC.

STOP UNIT

- On multi-temp units, leak test interconnecting tubing.
- Check and readjust all belt tensions per maintenance manual instructions.
- Check for oil, fuel, coolant, refrigerant, and exhaust leaks.
- Check engine oil and coolant level.
- Check entire unit for loosened hardware and fittings.
- Check and adjust all skin, door and panels for correct alignment and operation.
- Program per customer required setting.
- Check belt tension.
- Release unit.

WARRANTY REGISTRATION

- Commissioning OEM fills out sections 1, 2, 3, 5, 6 and signs section 7. Form is then returned to dealer where section 4 is completed, section 7 is signed and dealer registers unit in the Thermo King TAVANT Warranty Management System.
- Third Party Installers should ensure an authorized Thermo King Dealer performs a Pre-Delivery Inspection (PDI) and registers the unit in the Thermo King TAVANT Warranty Management System.

Pre-Delivery Inspection (PDI) Form Overview

PDI Form (TK 56641) is also included in the documents package of all vehicle powered truck units. This form is also available online at Thermo King ReqDirect. The PDI form is used when the unit installation was performed by someone other than the selling party. By completing the form, the **seller** confirms the unit operates as it should. PDI Forms should be completed for all unit sales and retained by the **seller**.

Completing both the Commissioning and the Pre-Delivery Forms helps assure Thermo King equipment is installed with the highest degree of quality, reliability, and durability to meet or exceed the expectations of our customers resulting in total customer satisfaction.

FORMS ARE LOCATED ON NEXT TWO PAGES



Figure 59. Page 1 of 2 Shown



Self-Powered Truck Pre-Delivery Inspection Form

Section 1 - Equipment Information	
Unit Serial No.	Date in Service:
Product: Self-Powered Truck	Truck No.:
Unit Model:	Break-in Beginning Hourmeter:
Install Date:	Break-in Ending Hourmeter:
VIN No.	OEM:

Section 2 – Serialized Component Information	
#1 Remote Evap Serial No.:	Add'l Component Part No. / Desc.:
#2 Remote Evap Serial No.:	Add'l Component Part No. / Desc.:
#3 Remote Evap Serial No.:	Add'l Component Part No. / Desc.:
Add'l Component Part No. / Desc.:	Add'l Component Part No. / Desc.:

Section 3 – Unit Installed By			
Installer Name:			
Address:	City:	State:	Zip Code:

Section 4 – Company Registering Unit			
Company Name:			
Address:	City:	State:	Zip Code:

Section 5 – Unit Owned By			
Company Name:			
Address:	City:	State:	Zip Code:

Section 6 – Unit Operated By			
Company Name:			
Address:	City:	State:	Zip Code:

Section 7 - Statement	
Important: This form certifies that the unit has been delivered in satisfactory operating condition. <u>The date of service should not exceed 90 days from date of installation.</u>	
Delivering Co. Signature:	End User Signature:

Further information can be found in the Self-Powered Single Temp Truck Installation Manual TK#56700 and the Multi-Temp Truck Installation Manual TK#56701 available through Thermo King Publications.

Figure 60. Page 2 of 2 Shown**BEFORE STARTING THE UNIT**

- Visually inspect unit for loose or improperly fitting bolts and brackets.
- Ensure hoses are properly routed and hose connections are secure.
- Check electrical connections for tightness and properly mating of battery cables.
- Check fluid levels (engine coolant and engine oil) and adjust as needed.

START AND RUN UNIT

- Run unit for 15 minutes while in cool mode.
- Perform full automated Pre-Trip Test per instructions.
- Observe unit for unusual noises while running and repair as needed.
- Ensure all fans are rotating in the proper direction:
 - Condenser fans should pull air in through the condenser coils.
 - Evaporator blowers should exhaust air through the evaporator outlet.
 - If unit is a multi-temp, check for proper operation of remote evaporator fans.
- Check for any oil, fuel, antifreeze, refrigerant, or exhaust leaks.
- Check unit for alarms generated during the Pre-Trip Test and repair as needed. (Do after performing steps above).
- Allow unit to run and check refrigerant level at a 0°F (-18°C) box temperature (while running in high speed cool per truck installation manual). If unit is a multi-temp, ensure all zones are in cool mode when this check is performed.
- Verify engine break-in procedure was completed by checking unit hourmeter. If it was not completed, operate the unit until 10 (minimum of 6) hours are shown on the engine run time hourmeter to verify complete break-in. Refer to TT692-1 for additional break-in information.
- As unit operates, it is critical that the Certified Technician inspects the unit every few hours and notes pull down rates, frequency, and duration of defrost cycles and general operations of the unit. Pull down times will vary and rates of temperature drop are dependent upon factors such as trailer size, insulation type and thickness and ambient temperature.

SMARTPOWER (ELECTRIC STANDBY) OPERATIONAL CHECKS IF EQUIPPED

- Connect unit to electric standby power and check for proper operation and rotation of electric standby motor, condenser fans and evaporator fans.
 - Note: When not connected to electric standby power, the standby motor contactor was not checked for proper operation during the full Pre-Trip Test performed earlier.

STOP UNIT

- Check for any oil, fuel, antifreeze, refrigerant, or exhaust leaks.
- Check engine oil level and engine coolant level gauge or indicator.
- Check and readjust all belt tensions per maintenance manual instructions.

WARRANTY REGISTRATION

- Commissioning Dealer completes the Warranty Registration process in the Thermo King TAVANT Warranty Management System.

Thermo King – by Trane Technologies (NYSE: TT), a global climate innovator – is a worldwide leader in sustainable transport temperature control solutions. Thermo King has been providing transport temperature control solutions for a variety of applications, including trailers, truck bodies, buses, air, shipboard containers and railway cars since 1938. For more information, visit www.thermoking.com or www.tranetechnologies.com.

Thermo King has a policy of continuous product and product data improvements and reserves the right to change design and specifications without notice. We are committed to using environmentally conscious print practices.

TK 56701-1-IM-EN 31 Aug 2020
Supersedes TK 56701-1-IM-EN (February 2020)

©2019 Trane Technologies