



Installation Manual

T-590, T-690, T-890 and T-1090 Series
Single Temperature Systems

Revision E

November 2023

TK 56700-1-IM-EN

TRANE
TECHNOLOGIES

Introduction

This manual was written to assist with the installation of Thermo King T-90 Series Systems onto truck bodies specifically designed and built for refrigerated applications. Separate installation instructions for Thermo King options (e.g., door switches, status light, fuel tanks, etc.) can be found at www.thermoking.com.

Due to its complexity, you should not attempt this installation unless you:

- Are an experienced mechanic.
- Can safely lift 34 kilos (75 lbs.).
- In the U.S., EPA 608 certified and trained in the repair and maintenance of transport refrigeration systems.
- Have a basic understanding of electricity and electrical wiring.
- Have the necessary tools and equipment to complete the installation.
- Have a truck body designed and built to meet the requirements of this installation.
- Follow all safety precautions outlined in this manual.

This manual is published for informational purposes only. Thermo King makes no representations warranties express or implied, with respect to the information recommendations and descriptions contained herein. Information provided should not be regarded as all-inclusive or covering all contingencies. If further information is required, Thermo King Corporation Service Department should be consulted.

Thermo King's warranty shall not apply to any equipment which has been "so installed, maintained, repaired or altered as, in the manufacturer's judgment, to affect its integrity."

Manufacturer shall have no liability to any person or entity for any personal injury, property damage or any other direct, indirect, special, or consequential damages whatsoever, arising out of the use of this manual or any information, recommendations or descriptions contained herein. The procedures described herein should only be undertaken by suitably qualified personnel. Failure to implement these procedures correctly may cause damage to the Thermo King unit or other property or personal injury.

Revision History

Revision A	(Sep 2019) New manual.
Revision B	(Feb 2020) Add information on installing unit without nut plates.
Revision C	(Aug 2020) Added information for EPA conformance regarding attaching label near fuel tank stating "ULTRA-LOW-SULFUR FUEL ONLY"
Revision D	(Mar 2023) Added sill gasket to installation kit.
Revision E	(Nov 2023) Update Alternate Installation Method by adding Option 090400.

Customer Satisfaction Survey

Let your voice be heard!

Your feedback will help improve our manuals. The survey is accessible through any internet-connected device with a web browser.

Scan the Quick Response (QR) code or click [Technical Publications TK Americas Feedback](#) to complete the survey.



Table of Contents

Safety Precautions	5
Danger, Warning, Caution, and Notice	5
General Practices	5
Refrigerant Hazards	6
Refrigerant Oil Hazards.....	6
Unit Installation Hazards.....	6
Fuel System Component Installation Hazards	8
Battery Installation and Cable Routing Hazards	8
First Aid.....	9
Returnable Steel Crate Information	11
Overview.....	11
Crate Breakdown Procedures	12
Important Storing and Return Shipping Information	13
Dimensions	14
Unit Dimensions and Weights	14
Unit Service Area Dimensions	16
Truck Body Opening Dimensions.....	18
Unit Lifting Bar Dimensions.....	20
HMI Controller Dimensions	25
Standby Power Receptacle Dimensions (OPTION)	26
Required Tools	28
Condensing Unit Installation Components	29
Installing Unit	31
Unit Mounting Bolt Requirements.....	31
Uncrating Procedures	33
Installation Procedures	34
Securing Oil Drain Hose	36
Securing Evaporator Drain Hoses	37
Installing USB Download Port (OPTION)	38
Securing Standby Power Receptacle (OPTION)	39
Installing HMI Controller	40
Steel or Aluminum Tank	41
Plastic Tank	42



Installing Fuel Pump and Fuel Lines	43
Battery Connections	44
Auxiliary Electrical Accessories	45
TrackKing (OPTION).....	45
Commissioning and PDI Forms	46
Commissioning Form Overview.....	46
Pre-Delivery Inspection (PDI) Form Overview.....	50

Safety Precautions

Danger, Warning, Caution, and Notice

Safety advisories appear throughout this manual as required. Your personal safety and the proper installation of this unit depend upon the strict observance of these precautions. The four types of advisories are defined as follows:

Danger

Hazard!

Indicates an imminently hazardous situation which, if not avoided, will result in death or serious injury.

Warning

Hazard!

Indicates a potentially hazardous situation which, if not avoided, could result in death or serious injury.

Caution

Hazard!

Indicates a potentially hazardous situation which, if not avoided, could result in minor or moderate injury and unsafe practices.

Notice

Hazard!

Indicates a situation that could result in equipment or property-damage only accidents.

General Practices

Danger

Hazardous Gases - Personal Protective Equipment (PPE) Required!

Refrigerant in the presence of an open flame, spark, or electrical short produces toxic gases that are severe respiratory irritants which can cause serious injury or possible death. When working with or around hazardous chemicals, ALWAYS refer to the applicable Material Data Safety Sheets (MSDS) and OSHA/GHS (Global Harmonized System of Classification and Labelling of Chemicals) guidelines for information on allowable personal exposure levels, proper respiratory protection, and handling instructions.

Danger

Refrigerant Vapor Hazard!

Do not inhale refrigerant. Use caution when working with refrigerant or a refrigeration system in any confined area with a limited air supply. Refrigerant displaces air and can cause oxygen depletion, resulting in suffocation and possible death. When working with or around hazardous chemicals, ALWAYS refer to the applicable Material Data Safety Sheets (MSDS) and OSHA/GHS (Global Harmonized System of Classification and Labelling of Chemicals) guidelines for information on allowable personal exposure levels, proper respiratory protection, and handling instructions.

Danger

Risk of Injury!

Keep your hands, clothing, and tools clear of fans and/or belts when working on a unit that is running or when opening or closing compressor service valves. Loose clothing might entangle moving pulleys or belts, causing serious injury or possible death.



⚠ Warning

Hazard of Explosion!

Never close the compressor discharge service valve when the unit is operating. Never operate the unit with the discharge valve closed (front seated). This condition increases internal pressure, which can cause an explosion.

⚠ Warning

Personal Protective Equipment (PPE) Required!

Always wear goggles or safety glasses and proper PPE when working on a unit. Refrigerant liquid, oil, and battery acid can permanently damage your eyes. When working with or around hazardous chemicals, ALWAYS refer to the applicable Material Data Safety Sheets (MSDS) and OSHA/GHS (Global Harmonized System of Classification and Labelling of Chemicals) guidelines for information on allowable personal exposure levels, proper respiratory protection, and handling instructions.

Refrigerant Hazards

⚠ Warning

Personal Protective Equipment (PPE) Required!

Refrigerant in a liquid state evaporates rapidly when exposed to the atmosphere, freezing anything it contacts. Wear butyl lined gloves and other clothing and eye wear when handling refrigerant to help prevent frostbite. When working with or around hazardous chemicals, ALWAYS refer to the applicable Material Data Safety Sheets (MSDS) and OSHA/GHS (Global Harmonized System of Classification and Labelling of Chemicals) guidelines for information on allowable personal exposure levels, proper respiratory protection, and handling instructions.

Refrigerant Oil Hazards

⚠ Warning

Personal Protective Equipment (PPE) Required!

Protect your eyes from contact with refrigerant oil. The oil can cause serious eye injuries. Protect skin and clothing from prolonged or repeated contact with refrigerant oil. To prevent irritation, wash your hands and clothing thoroughly after handling the oil. Rubber gloves are recommended. When working with or around hazardous chemicals, ALWAYS refer to the applicable Material Data Safety Sheets (MSDS) and OSHA/GHS (Global Harmonized System of Classification and Labelling of Chemicals) guidelines for information on allowable personal exposure levels, proper respiratory protection, and handling instructions.

Unit Installation Hazards

⚠ Danger

Fire Hazard!

Never bundle evaporator drain hose resistance wires together as the amount of heat produced could result in a fire!

⚠ Warning**Equipment Damage and Risk of Injury!**

Improper lifting of a refrigeration unit during installation can be dangerous. Thermo King requires a 3 point lifting bar to safely lift and install units. A lifting bar can be made from the drawings provided, however, all hardware used to assemble the lifting bar must be DIN 931 class 10.9 (SAE grade 8). The use of hardware other than specified may cause personal injury, severe damage to the equipment and void the warranty. All clevises, clevis pins and chain links must be forged steel with strength equal to the total lift capacity of hoist mechanism and that meet all safety standards.

⚠ Warning**Equipment Damage and Risk of Injury!**

Lifting and stacking refrigeration units in returnable steel crates can be dangerous. Forklifts must have the rated capacity to handle the combined weight of the refrigeration unit and the steel crate. Forklifts must also have the rated capacity to safely raise and stack crated units to a maximum of five (5) high.

⚠ Warning**Equipment Damage and Risk of Injury!**

Lifting, stacking and moving empty returnable steel crates can be dangerous. Empty steel crates can be stacked a maximum of twelve (12) high for storage. Forklifts must have the rated capacity to safely reach these heights while lifting an empty steel crate. When returning steel crates, they must be stacked a maximum of eight (8) high. Forklifts must have the rated capacity to safely raise and move a stack of eight (8) steel crates.

⚠ Warning**Equipment Damage and Risk of Injury!**

Never drill holes into the unit unless instructed by Thermo King. Holes drilled into high voltage cables could cause an electrical fire, severe personal injury, or even death.

⚠ Warning**Risk of Injury!**

When using ladders to install or service refrigeration systems, always observe the ladder manufacturer's safety labels and warnings. A work platform or scaffolding is the recommended method for installations and servicing.

📄 Notice**Equipment Damage!**

All unit mounting bolts must be installed, be the correct length for their application, and torqued to specifications. Missing bolts, incorrect bolt lengths and improper torque specifications can damage equipment and void the warranty.

📄 Notice**Equipment Damage!**

Cargo box ceiling must be structurally strong enough to support the weight of the SPECTRUM evaporator(s). Additional installer supplied supports may be required. Consult your cargo box/body builder for internal structure details.



Fuel System Component Installation Hazards

⚠ Danger

Combustible Hazard!

An improperly installed fuel pump or fuel lines could lead to serious injury or death. The Thermo King fuel pump should be installed onto the supplied mounting bracket. The fuel pump and fuel lines should be installed a safe distance away from the extreme heat generated by the vehicle's Diesel Particulate Filter (DPF) or exhaust system components on the truck.

⚠ Danger

Fire Hazard!

Do not route fuel lines with battery cables or electrical wires, as this could cause a fire.

⚠ Danger

Fire Hazard!

Leaking fuel lines could cause a fire resulting in death or serious injury. All fuel line fittings must be tight and leak free.

⚠ Danger

Hazard of Explosion!

Diesel fuel vapors are potentially explosive. Use extreme caution when drilling holes in or around diesel fuel tanks. Sparks from an electric drill or drill bit could cause an explosion. Drain all diesel fuel from the tank and use nitrogen or an inert gas to purge the diesel vapors from the tank prior to drilling into or around the fuel tank. Keep the diesel fuel tank filled with inert gas while drilling.

⚠ Danger

Hazard of Explosion!

An improperly installed fuel tank could lead to serious injury or death. Consult your truck's chassis manufacturer for specific details on proper fuel tank installation and recommendations.

Battery Installation and Cable Routing Hazards

⚠ Warning

Hazard of Explosion!

An improperly installed battery could result in a fire, explosion, or injury. A Thermo King approved battery must be installed and properly secured to the battery tray.

⚠ Warning

Hazard of Explosion!

Improperly installed battery cables could result in a fire, explosion, or injury. Battery cables must be installed, routed, and secured properly to prevent them from rubbing, chaffing, or making contact with hot, sharp, or rotating components.

⚠ Warning**Fire Hazard!**

Do not attach fuel lines to battery cables or electrical harnesses. This has the potential to cause a fire and could cause serious injury or death.

⚠ Warning**Hazard of Explosion!**

Always cover battery terminals to prevent them from making contact with metal components during battery installation. Battery terminals grounding against metal could cause the battery to explode.

⚠ Caution**Hazardous Service Procedures!**

Set all unit electrical controls to the OFF position before connecting battery cables to the battery to prevent the unit from starting unexpectedly and causing personal injury.

First Aid**REFRIGERANT**

- **Eyes:** For contact with liquid, immediately flush eyes with large amounts of water and get prompt medical attention.
- **Skin:** Flush area with large amounts of warm water. Do not apply heat. Remove contaminated clothing and shoes. Wrap burns with dry, sterile, bulky dressing to protect from infection. Get prompt medical attention. Wash contaminated clothing before reuse.
- **Inhalation:** Move victim to fresh air and use CPR (cardio pulmonary resuscitation) or mouth-to-mouth resuscitation to restore breathing, if necessary. Stay with victim until emergency personnel arrive.
- **Frost Bite:** In the event of frost bite, the objectives of First Aid are to protect the frozen area from further injury, warm the affected area rapidly, and to maintain respiration.

REFRIGERANT OIL

- **Eyes:** Immediately flush with large amounts of water for at least 15 minutes. Get prompt medical attention.
- **Skin:** Remove contaminated clothing. Wash thoroughly with soap and water. Get medical attention if irritation persists.
- **Inhalation:** Move victim to fresh air and use CPR (cardio pulmonary resuscitation) or mouth-to-mouth resuscitation to restore breathing, if necessary. Stay with victim until emergency personnel arrive.
- **Ingestion:** Do not induce vomiting. Immediately contact local poison control center or physician.

ENGINE COOLANT

- **Eyes:** Immediately flush with large amounts of water for at least 15 minutes. Get prompt medical attention.
- **Skin:** Remove contaminated clothing. Wash thoroughly with soap and water. Get medical attention if irritation persists.
- **Ingestion:** Do not induce vomiting. Immediately contact local poison control center or physician.

BATTERY ACID

- **Eyes:** Immediately flush with large amounts of water for at least 15 minutes. Get prompt medical attention. Wash skin with soap and water.
- **Skin:** Immediately remove contaminated clothing. Wash skin with large volumes of water, for at least 15 minutes. Wash skin with soap and water. Do not apply fatty compounds. Seek immediate medical assistance.
- **Inhalation:** Provide fresh air. Rinse mouth and nose with water. Seek immediate medical assistance.
- **Ingestion:** If the injured person is fully conscious: make the person drink extensive amounts of milk. Do not induce vomiting. Take the injured person immediately to a hospital.

ELECTRICAL SHOCK



Safety Precautions

Take IMMEDIATE action after a person has received an electrical shock. Get quick medical assistance, if possible.

The source of the shock must be quickly stopped, by either shutting off the power or removing the victim. If the power cannot be shut off, the wire should be cut with a non-conductive tool, such as a wood-handle axe or thickly insulated cable cutters. Rescuers should wear insulated gloves and safety glasses, and avoid looking at wires being cut. The ensuing flash can cause burns and blindness.

If the victim must be removed from a live circuit, pull the victim away with a non-conductive material. Use wood, rope, a belt or coat to pull or push the victim away from the current. DO NOT TOUCH the victim. You will receive a shock from current flowing through the victim's body. After separating the victim from power source, immediately check for signs of a pulse and respiration. If no pulse is present, start CPR (cardio pulmonary resuscitation). If a pulse is present, respiration might be restored by using mouth-to-mouth resuscitation. Call for emergency medical assistance.

ASPHYXIATION

Move victim to fresh air and use Cardio Pulmonary Resuscitation (CPR) or mouth-to-mouth resuscitation to restore breathing, if necessary. Stay with victim until emergency personnel arrive.

Returnable Steel Crate Information

Overview

Important: Safety precautions must be followed. Refer to **Unit Installation Hazards** in the **Safety Precautions** section of this manual before proceeding.

The information provided in this section must be followed when handling self-powered truck units in steel returnable crates:

- Returnable steel crates “nest” for stacking by utilizing an interlocking design. This design utilizes four “pins” located on top of the support members that fit into pockets on the bottom of another support member. When stacking crated self-powered truck units, be sure the pins are fully seated into the pockets.
- Use only the provided forklift pockets to lift steel crated self-powered truck units.
- When storing steel crated self-powered truck units, do not stack over five (5) high.

Important: Your forklift must be rated for the combined weight of the self-powered truck unit and the steel crate. See table below.

UNIT MODEL	UNIT WEIGHT (approximate)	STEEL CRATE WEIGHT	TOTAL WEIGHT OF UNIT WITH STEEL CRATE
T-590 Model 30 T-590 SmartPower Model 50	413 kg (910 lbs.) 441 kg (973 lbs.)	236 kg (520 lbs.)	649 kg (1430 lbs.) 677 kg (1493 lbs.)
T-690 Model 30 T-690 Model 30 MAX T-690 SmartPower Model 50 T-690 SmartPower Model 50 MAX	413 kg (910 lbs.) 429 kg (947 lbs.) 441 kg (973 lbs.) 458 kg (1010 lbs.)		649 kg (1430 lbs.) 665 kg (1467 lbs.) 677 kg (1493 lbs.) 694 kg (1530 lbs.)
T-890 Model 30 T-890 Model 30 MAX T-890 SmartPower Model 50 T-890 SmartPower Model 50 MAX	437 kg (990 lbs.) 466 kg (1027 lbs.) 462 kg (1099 lbs.) 515 kg (1136 lbs.)		685 kg (1510 lbs.) 702 kg (1547 lbs.) 734 kg (1619 lbs.) 751 kg (1656 lbs.)
T-1090 Model 30 T-1090 Model 30 MAX T-1090 SmartPower Model 50 T-1090 SmartPower Model 50 MAX	453 kg (1014 lbs.) 477 kg (1051 lbs.) 502 kg (1123 lbs.) 526 kg (1160 lbs.)		696 kg (1534 lbs.) 713 kg (1571 lbs.) 745 kg (1643 lbs.) 762 kg (1680 lbs.)
T-1090 SPECTRUM Model 30 T-1090 SPECTRUM SmartPower Model 50	400 kg (883 lbs.) 450 kg (992 lbs.)		636 kg (1403 lbs.) 686 kg (1512 lbs.)

Crate Breakdown Procedures

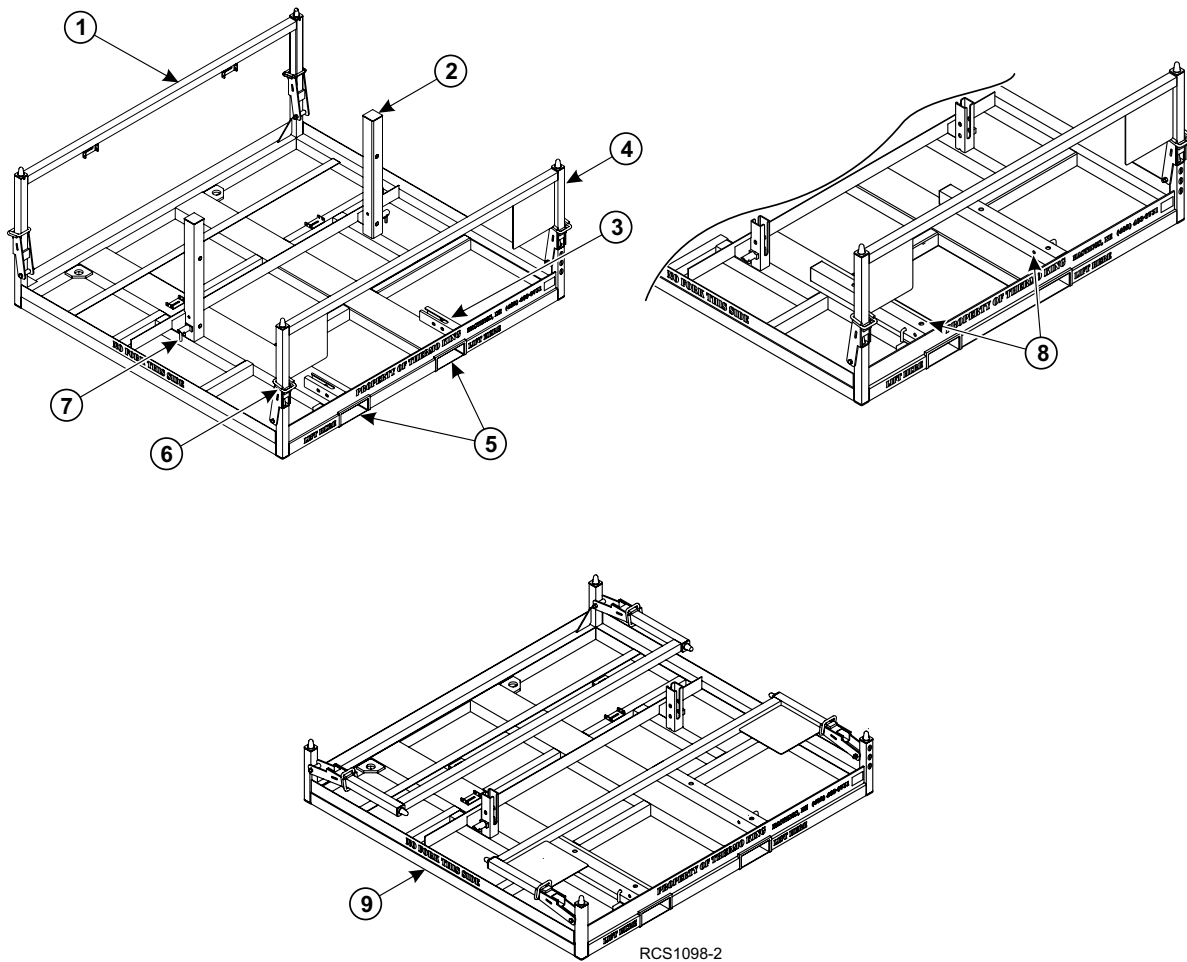
Follow these steps after unit has been removed from crate:

1. Remove mounting posts by rotating twist-lock handle to **UP** position, then pulling straight up.
 - a. Slide each post into retaining channels located on crate base.
 - b. Rotate twist-lock handle to secure posts to channels.

Note: Mounting posts *must* be secured to retaining channels for shipment.

2. Fold down front and rear supports by sliding locking rings **UP** until they rest on tab, then fold each support member down flat.
3. Crate is now ready to return.

Figure 1. Returnable Crate Components Shown



1.	Rear Support Member	6.	Locking Rings (X4)
2.	Mounting Posts (X2)	7.	Twist Locks (X2)
3.	Retaining Channels (X2)	8.	Mounting Post Secured to Retaining Channels
4.	Front Support Member	9.	Crate Shown Ready to Return
5.	Forklift Pockets (X2)		

Important Storing and Return Shipping Information

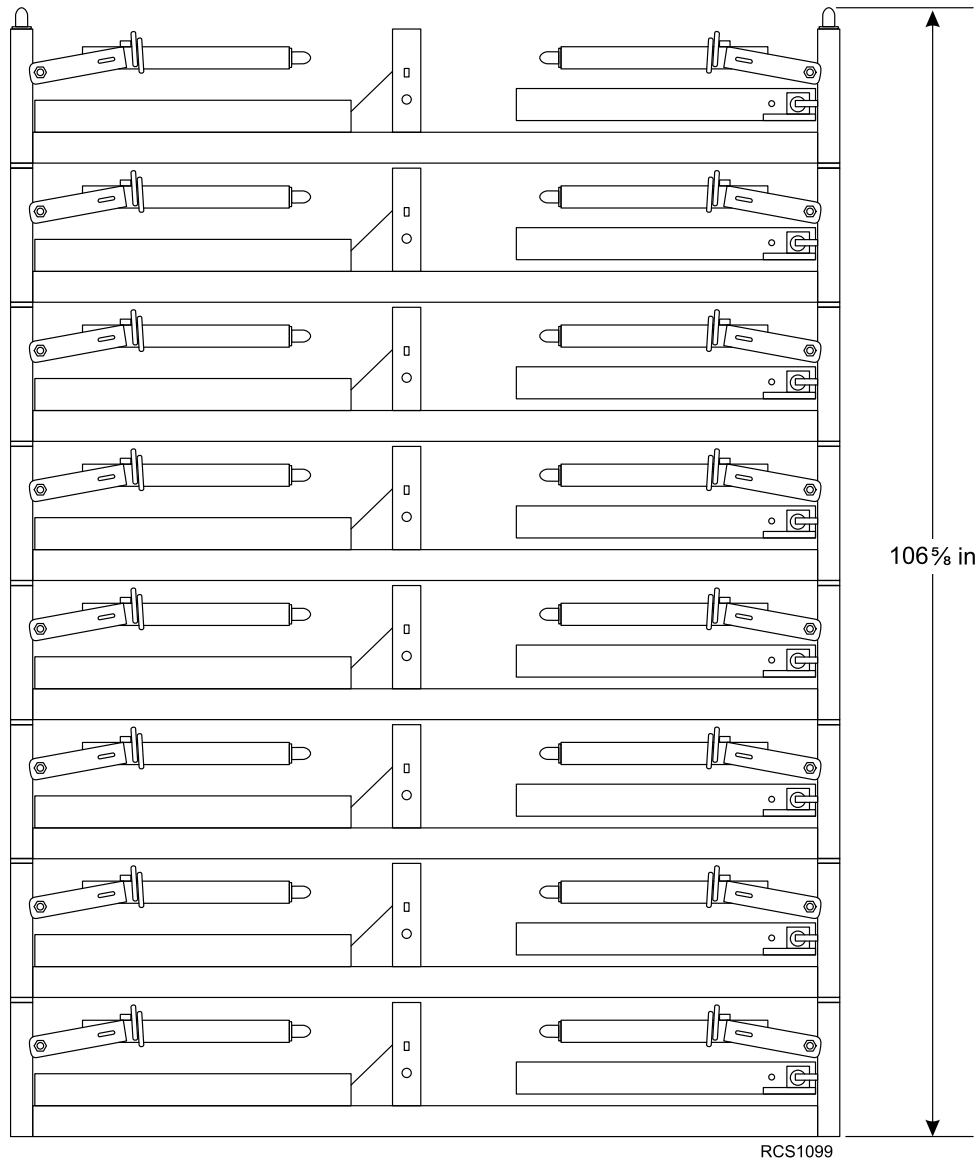
Empty crates can be stacked up to twelve (12) high for storage.

Important: Be sure your forklift can safely reach these heights while lifting a 236 kg (520 lb.) crate.

When returning crates, they should be stacked no more than eight (8) high.

Important: Eight (8) crates @ 236 kg (520 lbs.) = 1,887 kg (4,160 lbs): Be sure your forklift is rated for this amount of weight.

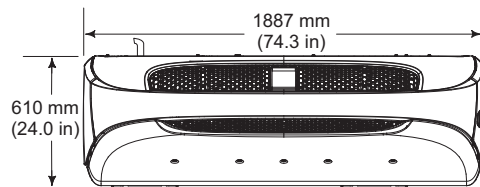
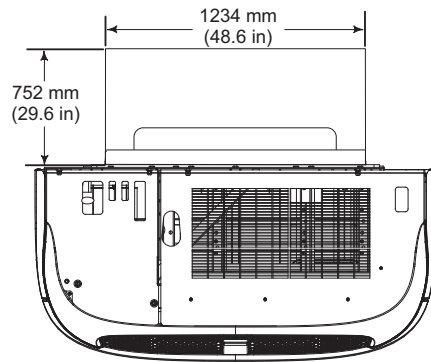
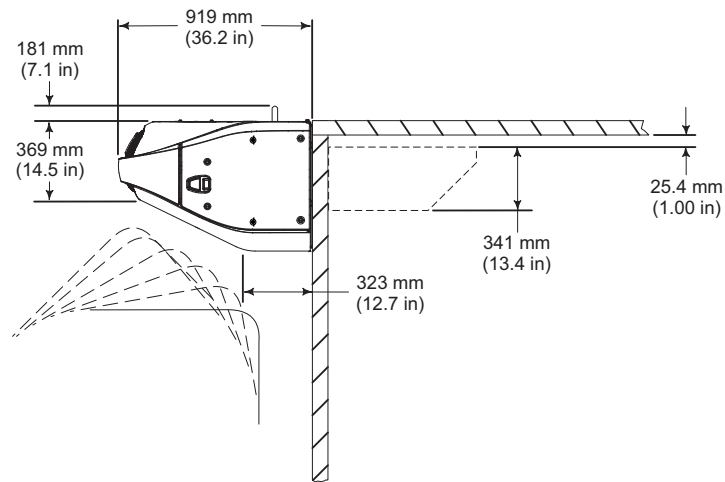
Figure 2. Crates Shown Stacked for Return – Maximum Eight (8) High



Dimensions

Unit Dimensions and Weights

Figure 3. T-590 and T-690 Units

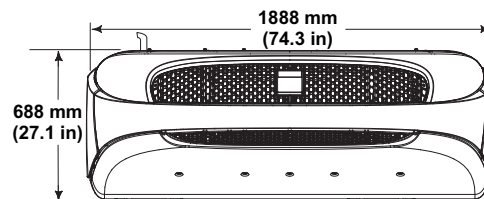
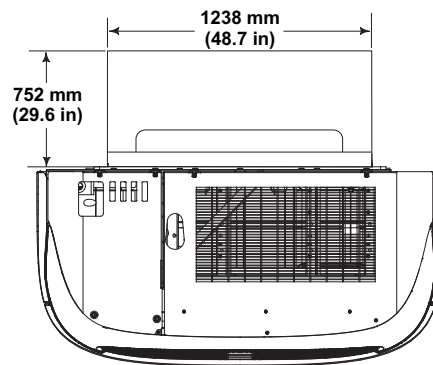
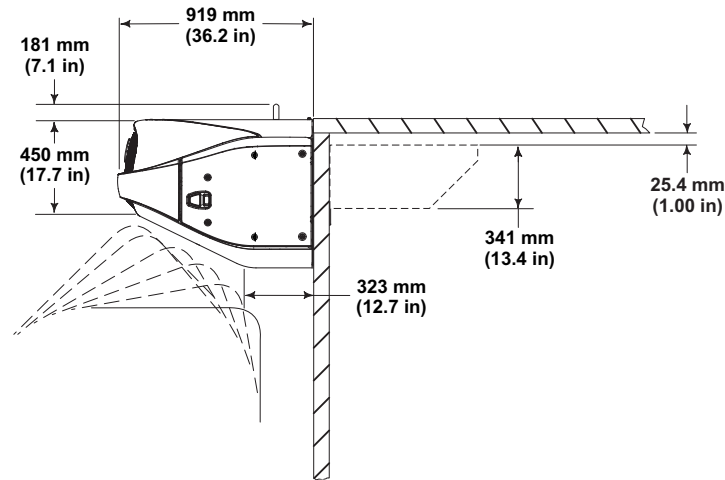


RCS1074-6

1. Top of unit is to be mounted flush with top of cargo box when possible. Top of evaporator is to be positioned 25.4 mm (1.00 in.) below ceiling. Dimension from the top of cargo box to evaporator cutout may vary depending on type of box, truck cab tilt clearance, etc.

UNIT	MODEL 30	Model 50 (SmartPower)
T-590	910 lbs. (413 kg)	973 lbs. (441 kg)
T-690 T-690 MAX	910 lbs. (413 kg) 947 lbs. (429 kg)	973 lbs. (441 kg) 1010 lbs. (458 kg)

Figure 4. T-890 and T-1090 Units



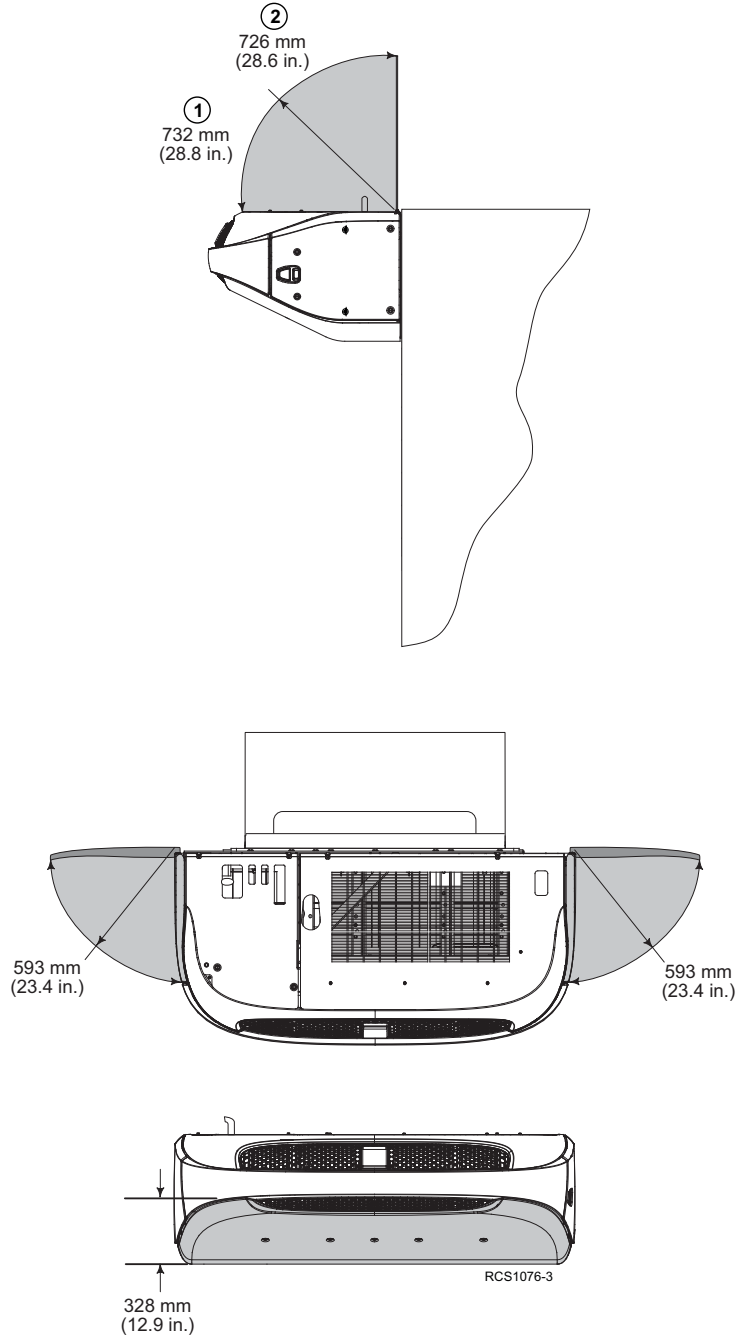
RCS1075-6

1. Top of unit is to be mounted flush with top of cargo box when possible. Top of evaporator is to be positioned 25.4 mm (1.00 in.) below ceiling. Dimension from the top of cargo box to evaporator cutout may vary depending on type of box, truck cab tilt clearance, etc.

UNIT	MODEL 30	Model 50 (SmartPower)
T-890 T-890 MAX	990 lbs. (437 kg) 1027 lbs. (466 kg)	1099 lbs. (462 kg) 1136 lbs. (515 kg)
T-1090 T-1090 MAX	1014 lbs. (453 kg) 1051 lbs. (477 kg)	1123 lbs. (502 kg) 1160 Lbs. (526 kg)

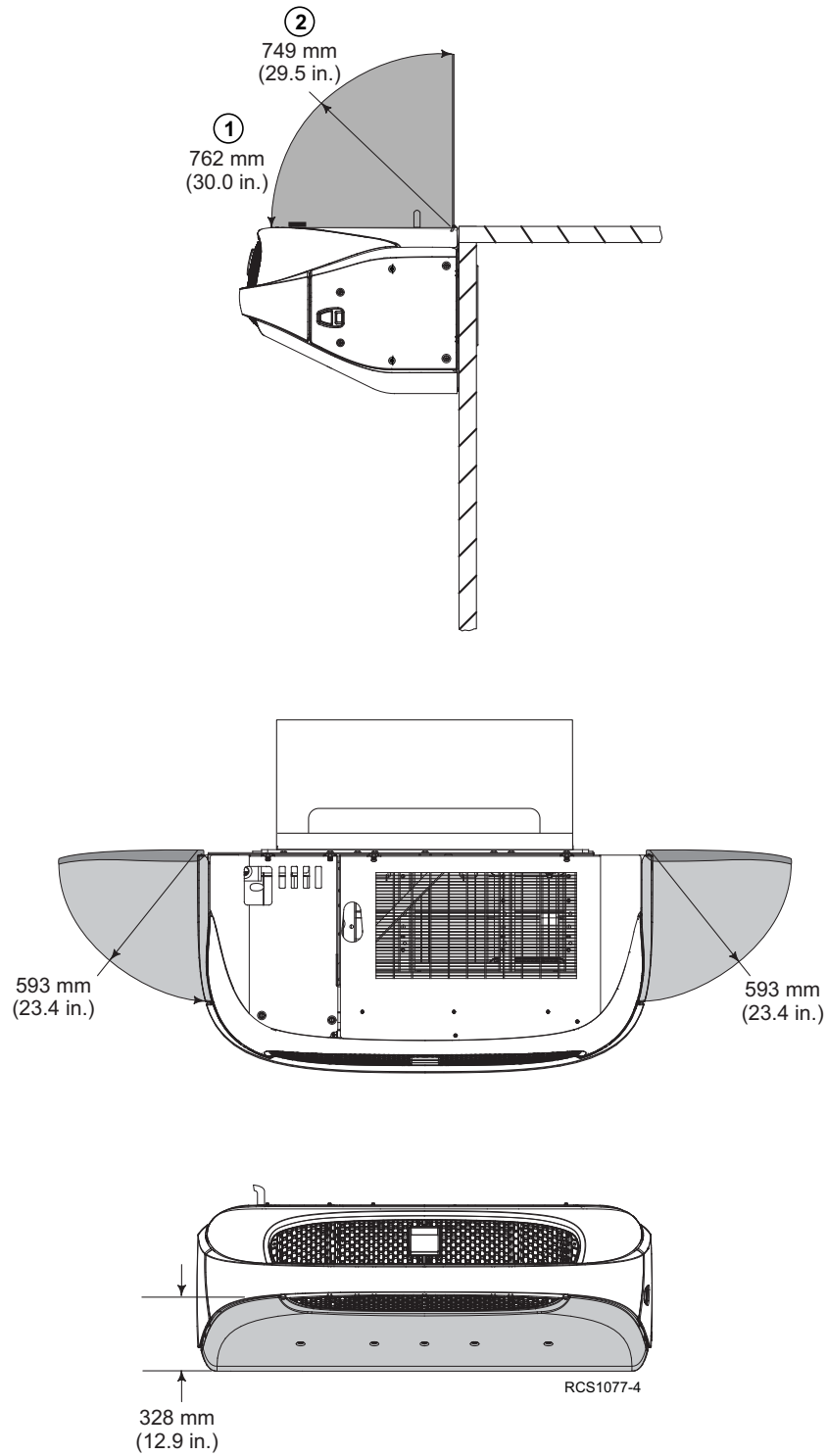
Unit Service Area Dimensions

Figure 5. T-590 and T-690 Units



1.	Service Area Dimensions with Top Screen (Option)	2.	Service Area Dimensions with Top Cover (Option)
----	--	----	---

Figure 6. T-890, T-1090 and T-1090 SPECTRUM Units



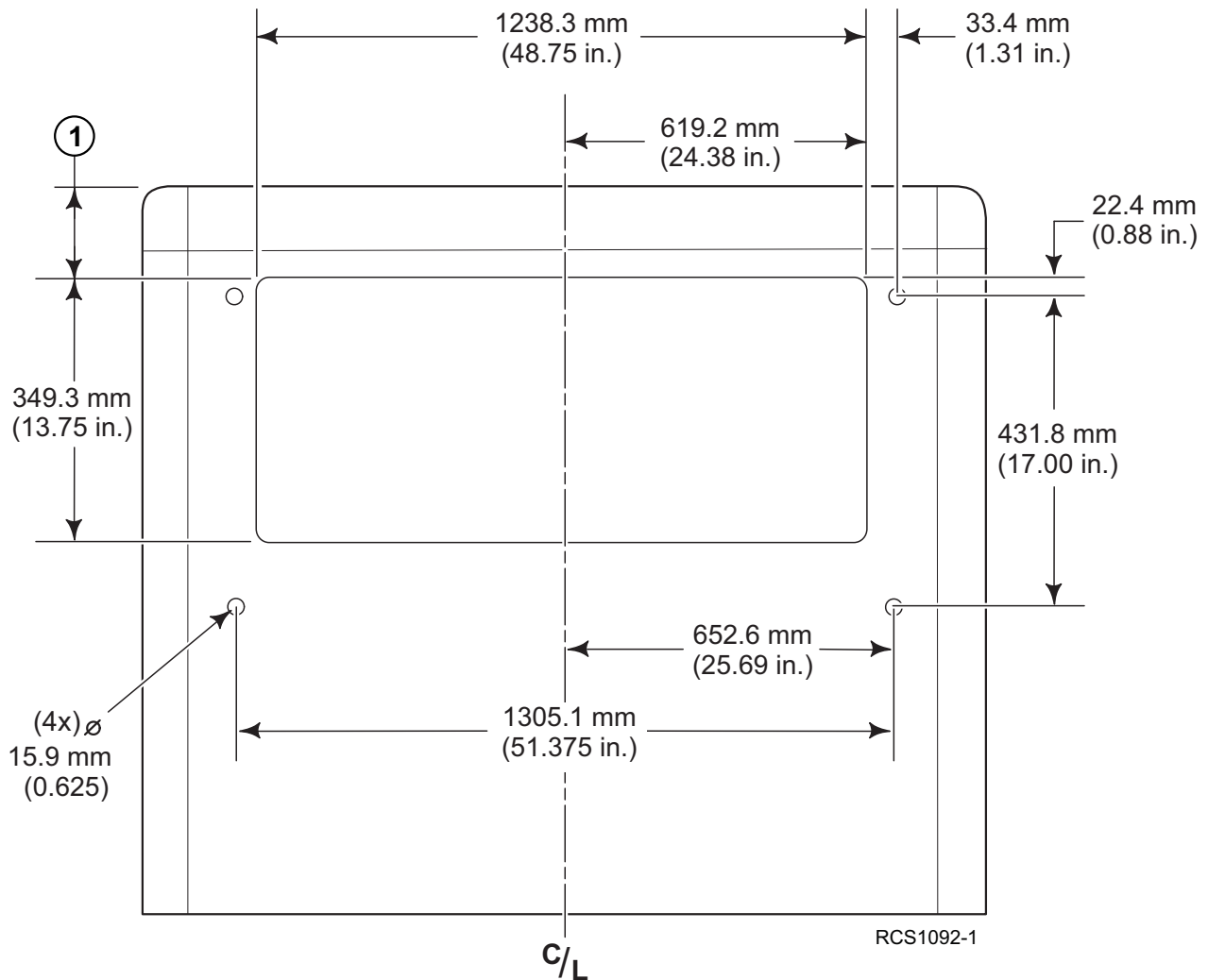
1.	Service Area Dimensions with Top Screen (Option)	2.	Service Area Dimensions with Top Cover (Option)
----	--	----	---

Truck Body Opening Dimensions

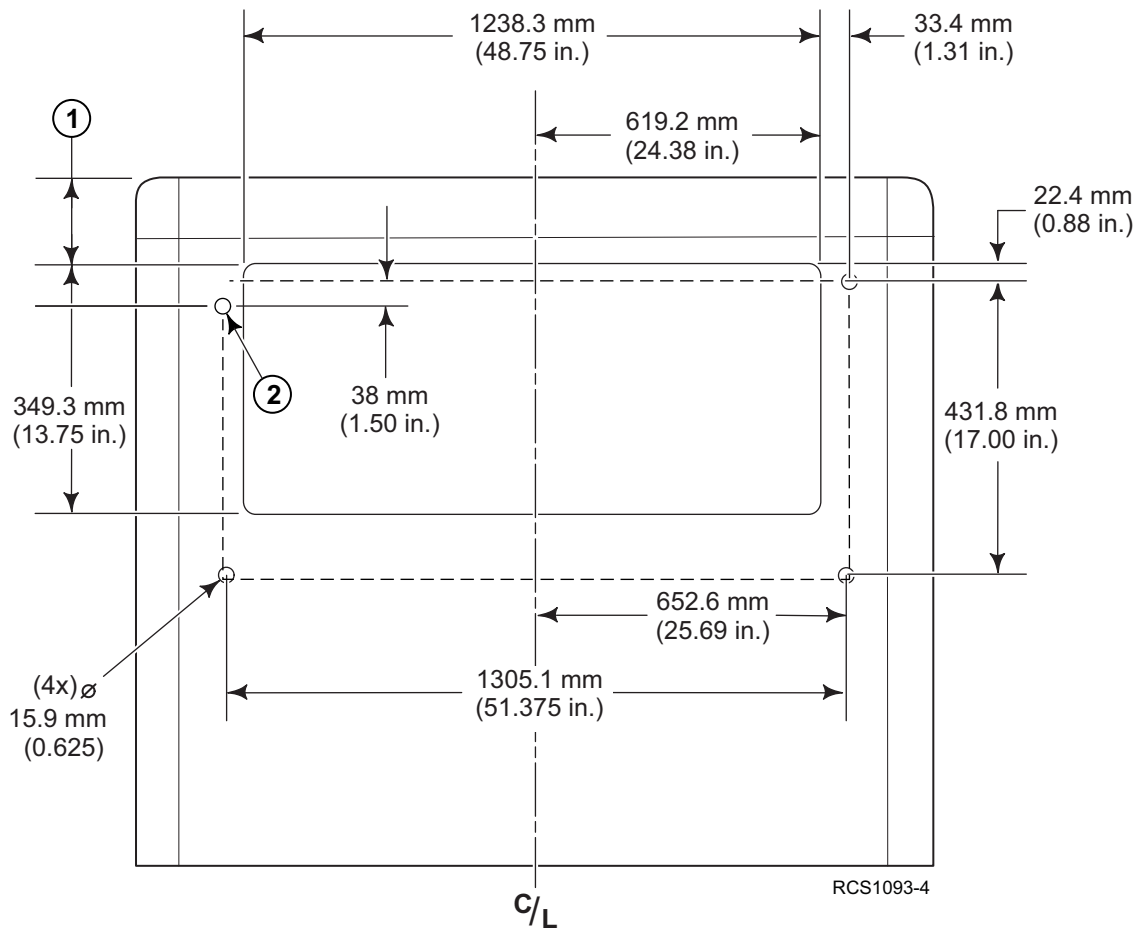
The following requirements must be followed for all T-90 series truck units:

- Truck body opening dimensions and mounting hole locations must be correct for proper unit installation.
- Gasket sealing surface of 50.8 mm (2.00 in.) wide is required around unit opening. This surface must be flat within 6.4 mm (0.25 in.) and free of all rivets or bolt heads for proper gasket sealing.
- Unit mounting location must allow for adequate truck cab tilt clearance.

Figure 7. T-590 and T-690 Only — Front View of Truck Body Opening Dimensions From Outside of Truck



- | | |
|----|---|
| 1. | Top of unit is to be mounted flush with top of cargo box when possible. Top of evaporator is to be positioned 25.4 mm (1.00 in.) below ceiling. Dimension from the top of cargo box to evaporator cutout may vary depending on type of box, truck cab tilt clearance, etc. T-590 through T-690 series units minimum dimensions = 107 mm (4.25 in.). |
|----|---|

Figure 8. T-890 and T-1090 Only – Front View of Truck Body Opening Dimensions From Outside of Truck


1.	Top of unit is to be mounted flush with top of cargo box when possible. Top of evaporator is to be positioned 25.4 mm (1.00 in.) below ceiling. Dimension from the top of cargo box to evaporator cutout may vary depending on type of box, truck cab tilt clearance, etc.
2.	Note this upper curbside mounting hole is lower than previous T-Series units.

Figure 10. Lifting Bar Dimensions – Page 2

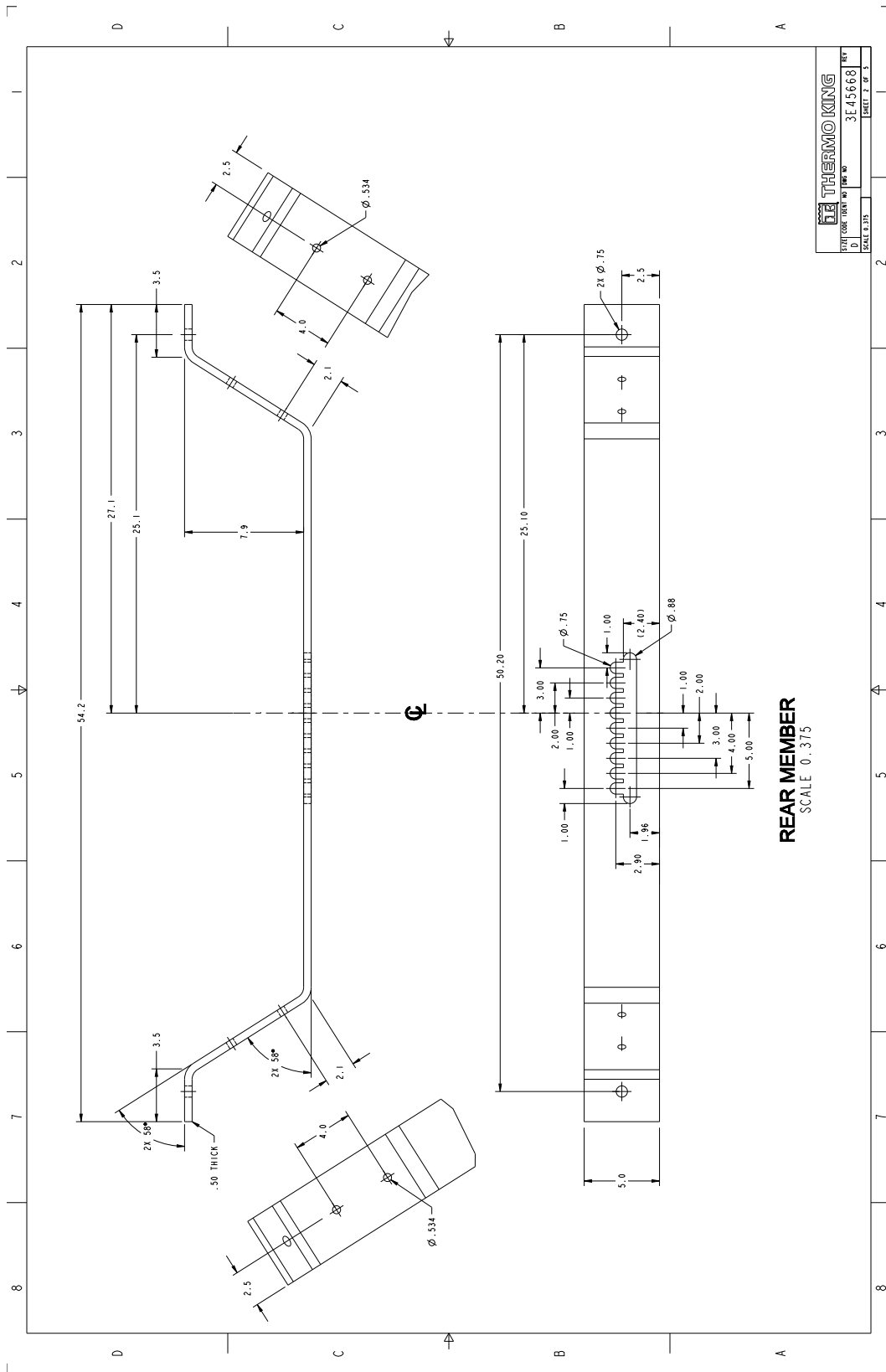


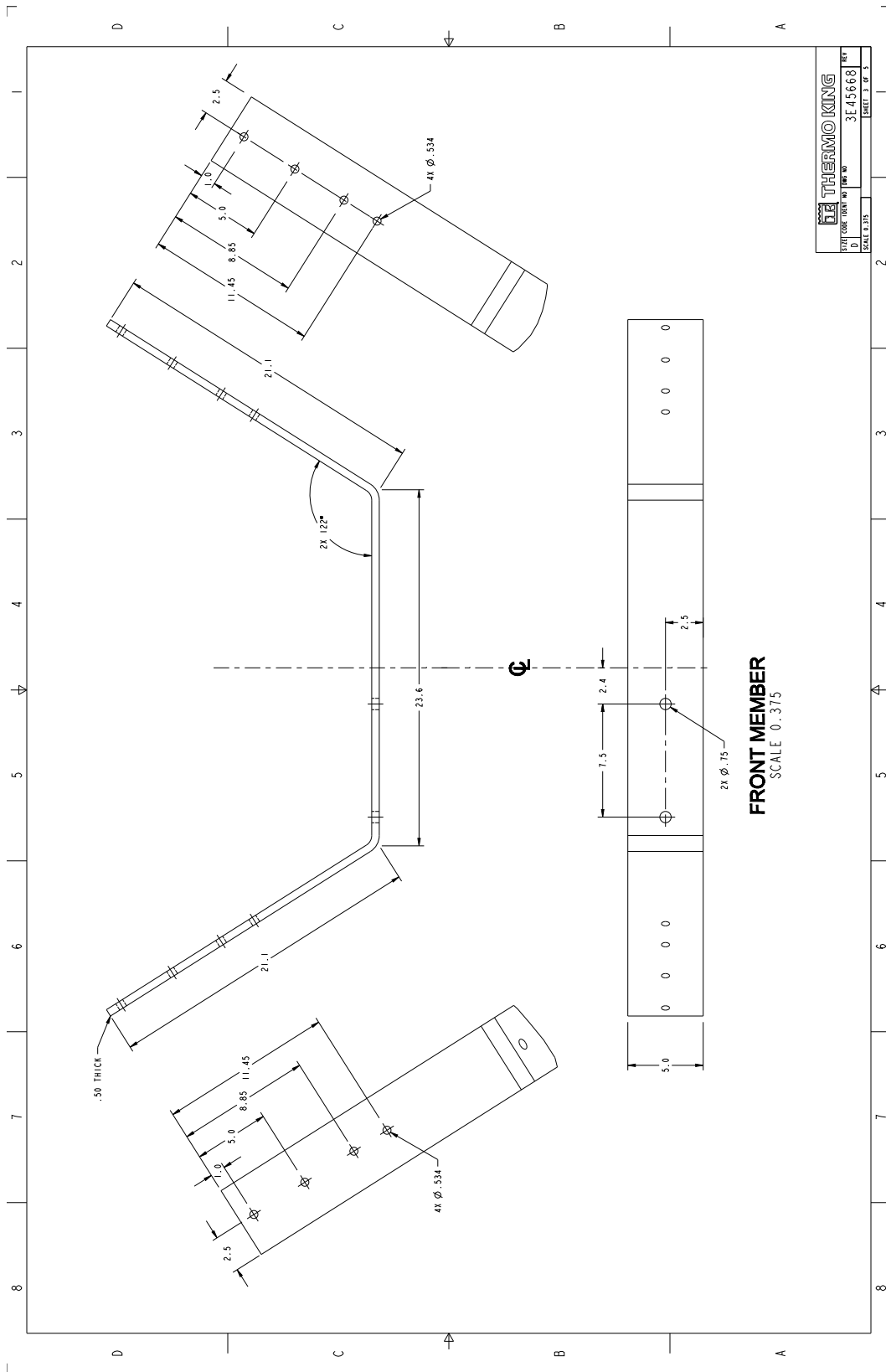
Figure 11. Lifting Bar Dimensions – Page 3


Figure 12. Lifting Bar Dimensions – Page 4

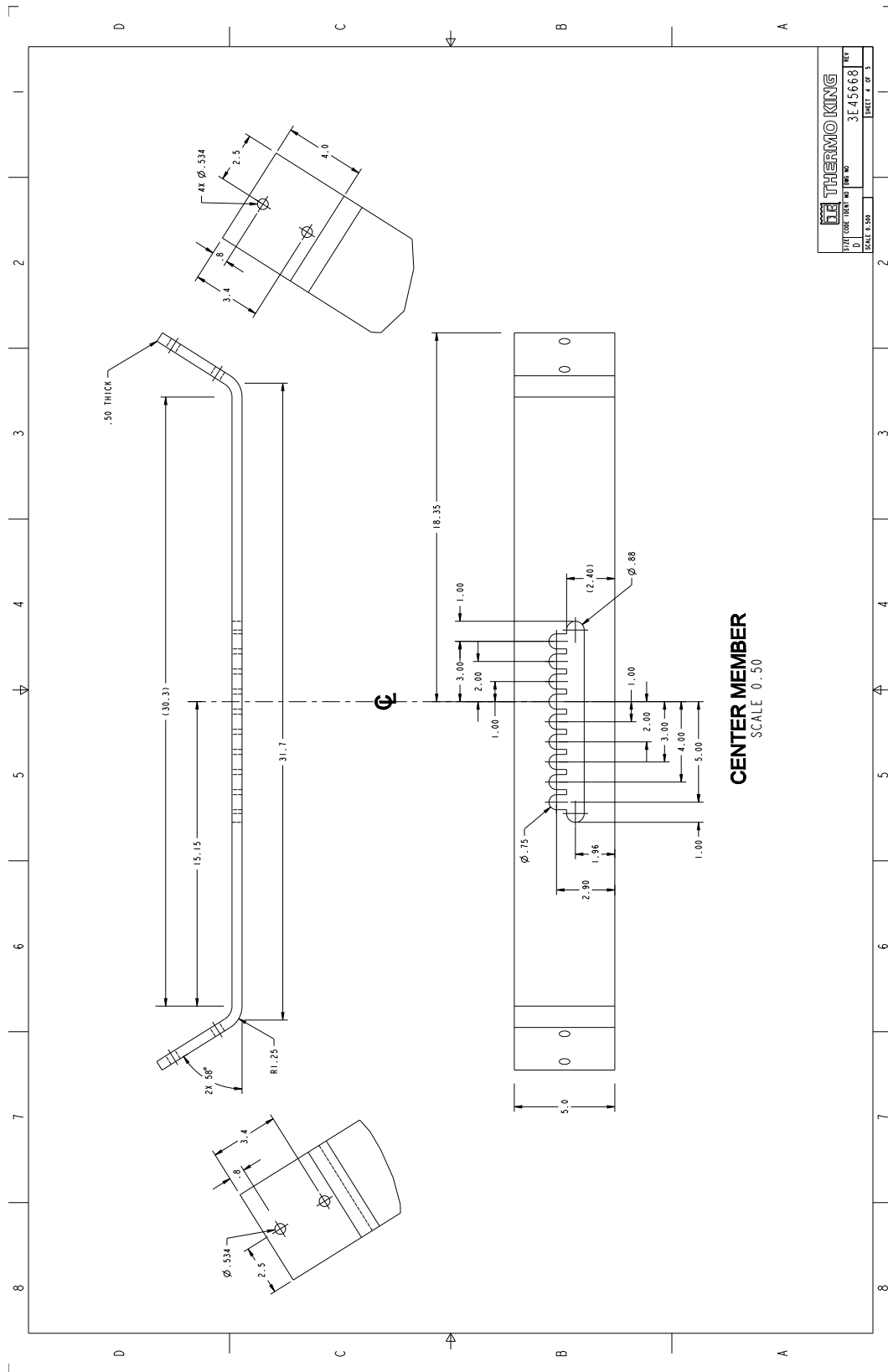
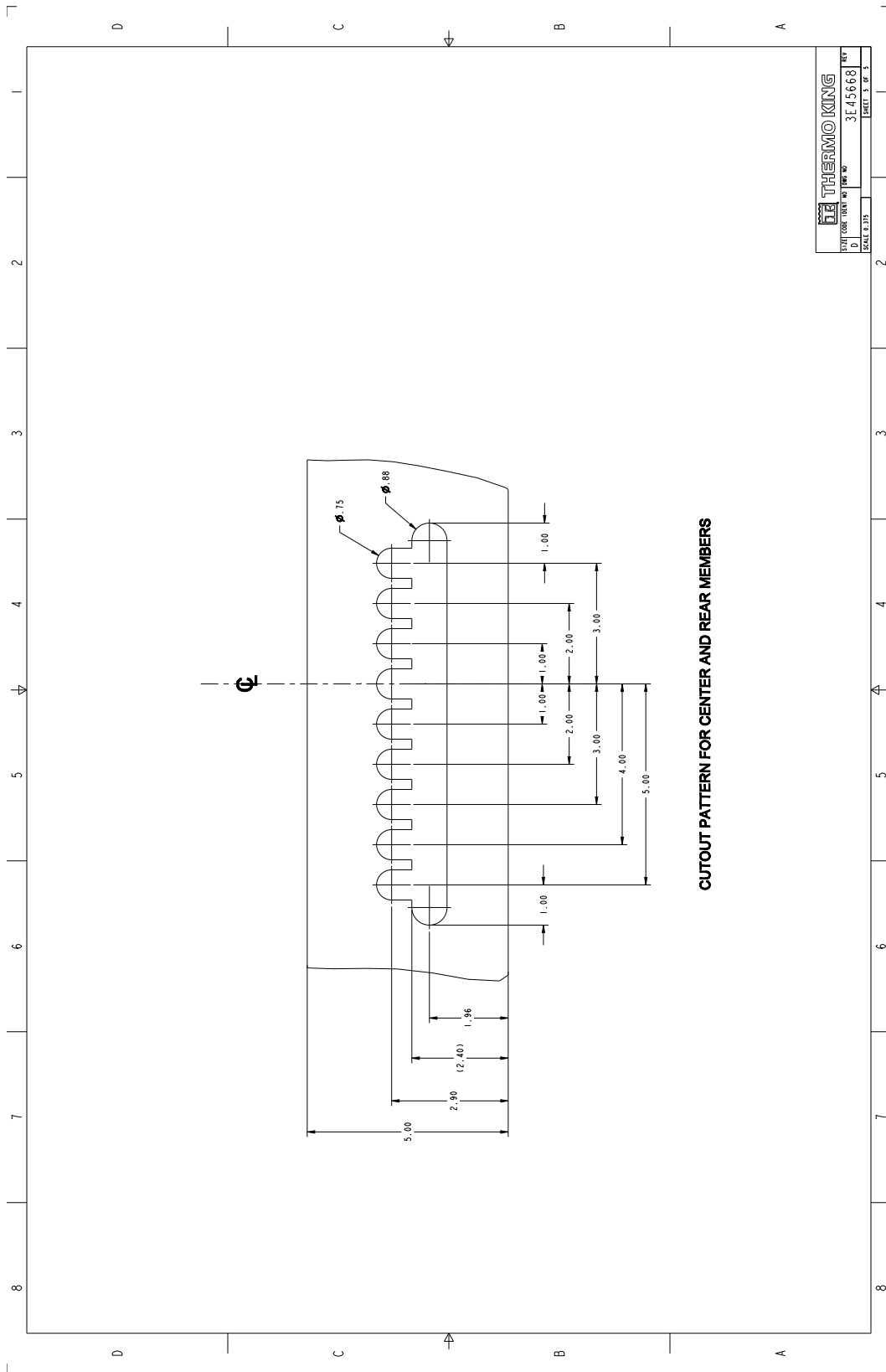
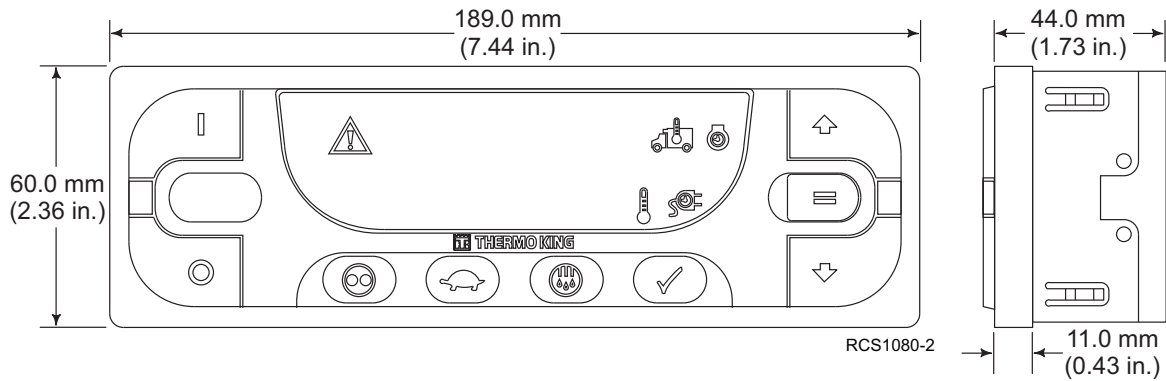
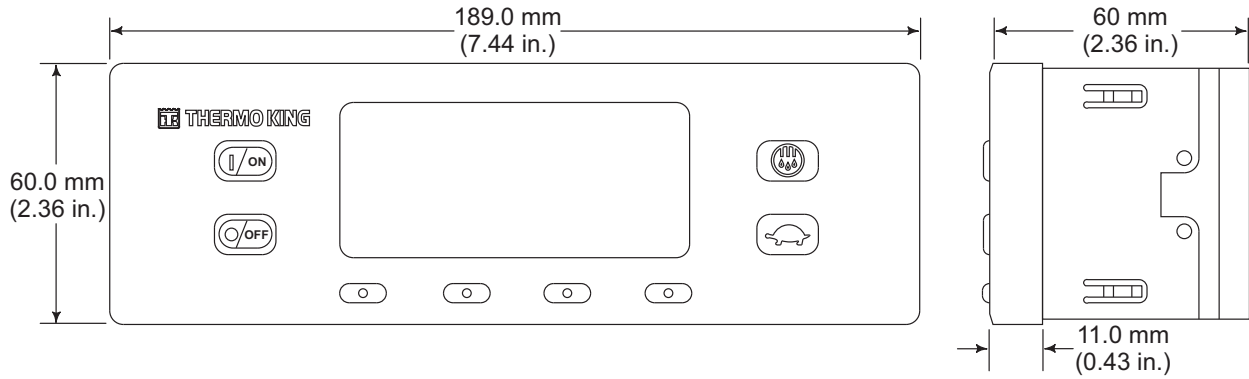


Figure 13. Lifting Bar Dimensions – Page 5


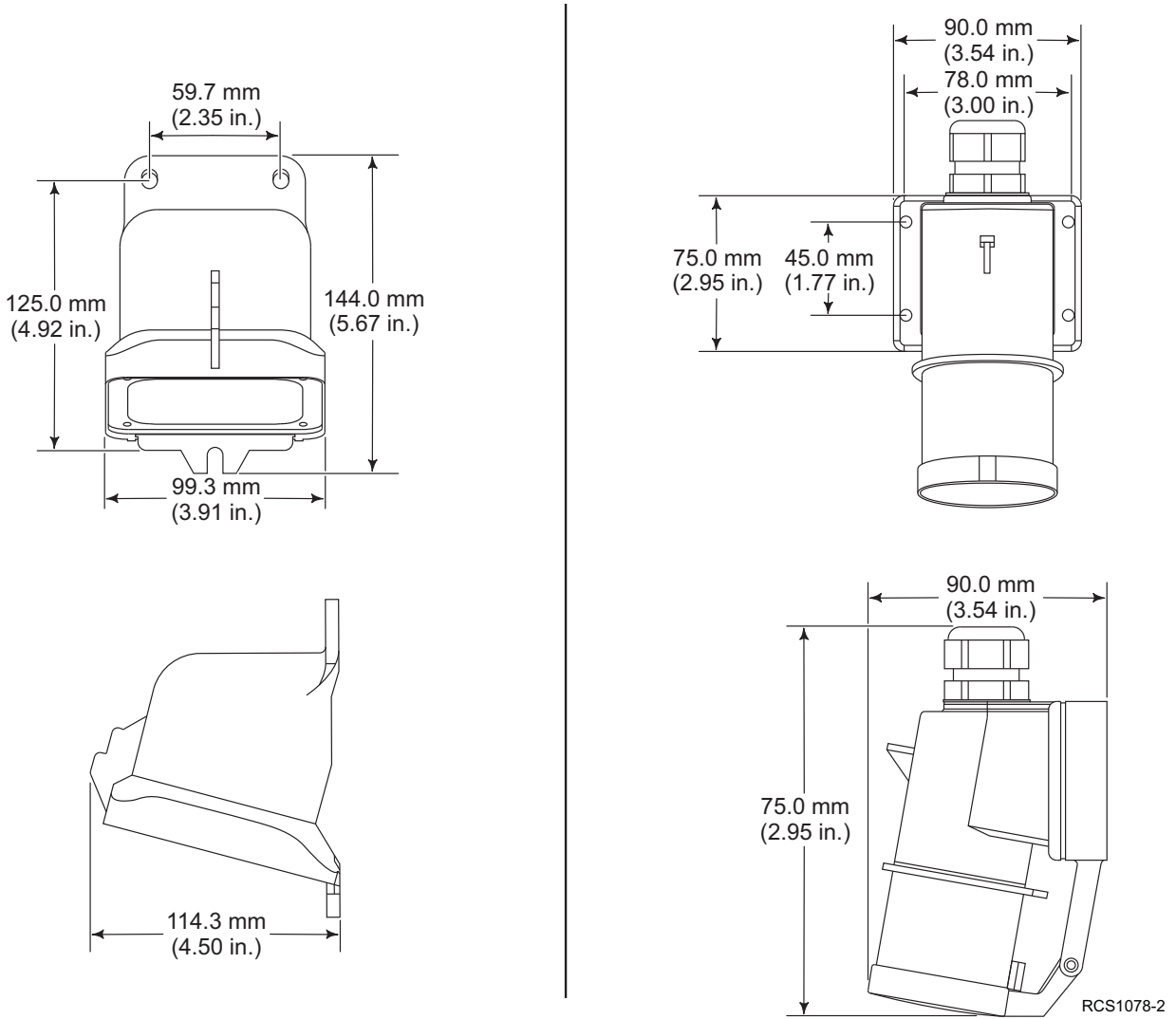
HMI Controller Dimensions

Figure 14. Premium and Basic HMI Controllers Shown



Standby Power Receptacle Dimensions (OPTION)

Figure 15. North American and International Model Receptacles Shown

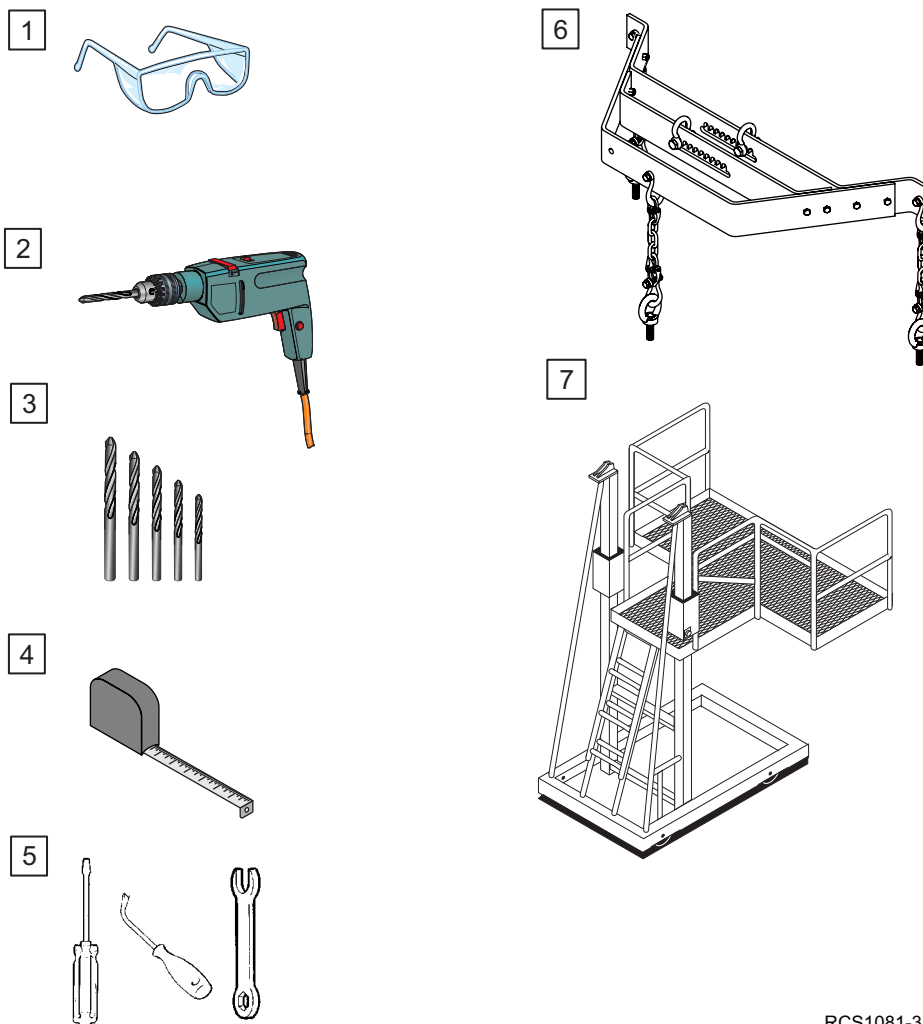


PAGE INTENTIONALLY BLANK

Required Tools

1. Safety Glasses
2. Drill
3. Drill Bits
4. Tape Measure
5. Mechanics Tools
6. Lifting Bar (Thermo King design) with forged links, clevises and pins.
7. Work Platform (recommended)

Figure 16. Required Tools Shown



RCS1081-3

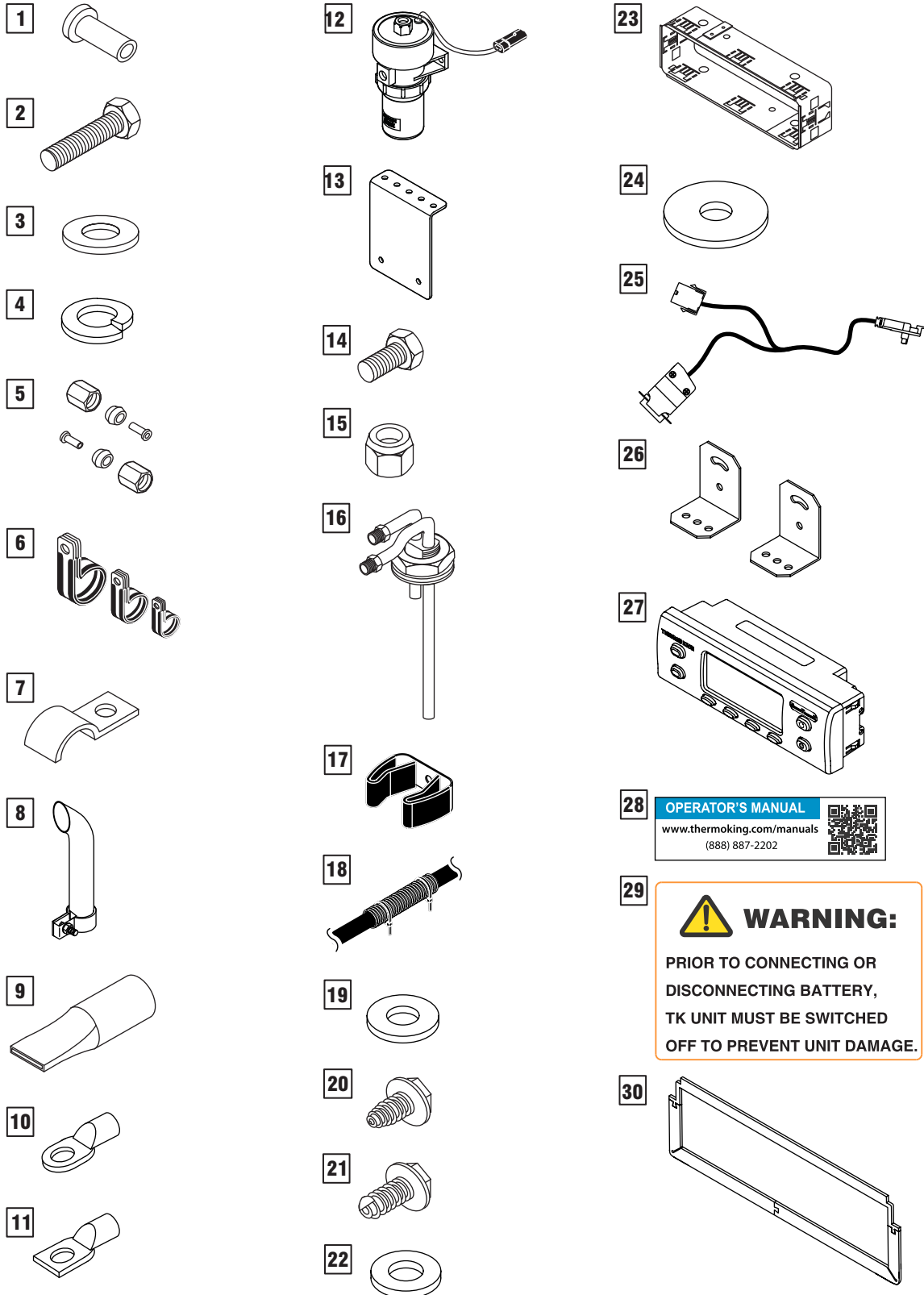
Condensing Unit Installation Components

Note: The following installation components are provided to complete a standard condensing unit installation. Customer ordered options are not shown.

1. Nut-Blind
2. Screw, 1/4"–20
3. Flat Washer, 1/4"
4. Lock Washer, 1/4"
5. Fuel Fittings
6. Insulated Clamps
7. Clamp
8. Exhaust Pipe Extension
9. Check Valve
10. Terminal Lug, 3/8" 2 AWG
11. Terminal Lug, 3/8" red
12. Fuel Pump
13. Fuel Pump Mounting Bracket
14. Screw, 1/4"–20
15. Lock Nut, 1/4"-20
16. Fuel Pickup Tube Assembly
17. Clip
18. Fuse, In-line 60 Amp
19. Flat Washer #10
20. Screw, #10
21. Screw, #8
22. Washer, #8
23. DIN Bracket
24. Washer, 2" OD
25. Premium HMI Harness Adapter
26. HMI In-Cab Mounting Brackets
27. Premium HMI Controller
28. Operator's Manual QR Code Nameplate
29. Warning Nameplate
30. Sill Gasket (3 pieces)



Figure 17. Condensing Unit Installation Components Shown



RCS1082-2

Installing Unit

Unit Mounting Bolt Requirements

Notice

Equipment Damage!

All unit mounting bolts must be installed, be the correct length for their application, and torqued to specifications. Missing bolts, incorrect bolt lengths and improper torque specifications can damage equipment and void the warranty.

Unit mounting bolts must meet the following requirements:

Bolt Size and Thread Pitch	1/2-13 UNC, Full Thread
Grade	SAE Grade 5 (ISO 8.8)
Finish	Zinc Dichromate, Cadmium Plated.
Length	<p>The length of each of the four mounting bolts protruding from the front wall of the cargo box is shown in the illustration.</p> <ul style="list-style-type: none"> • Three bolts are the same length. • One bolt is longer. • After unit is installed, a minimum of 2 thread pitches must extend beyond the surface of the nut.
Torque Specifications	81.4 N•m (60 ft-lb.)
Important: Apply blue thread locker to all four (4) unit mounting bolts during unit installation.	

Figure 18. Confirm a minimum of 2 thread pitches extend beyond the surface of the nut.

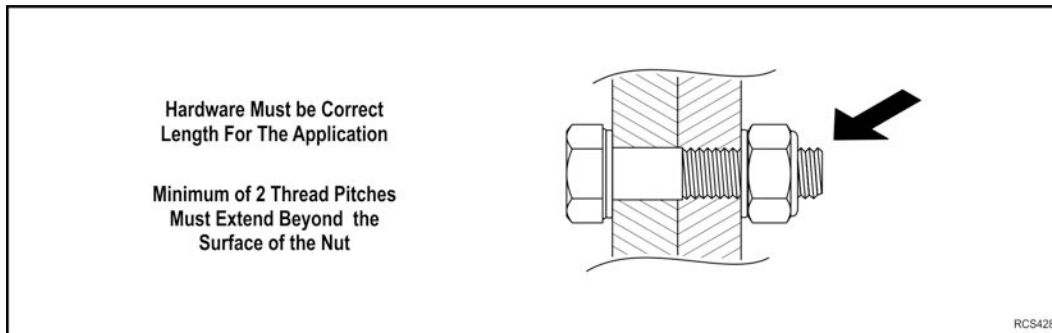
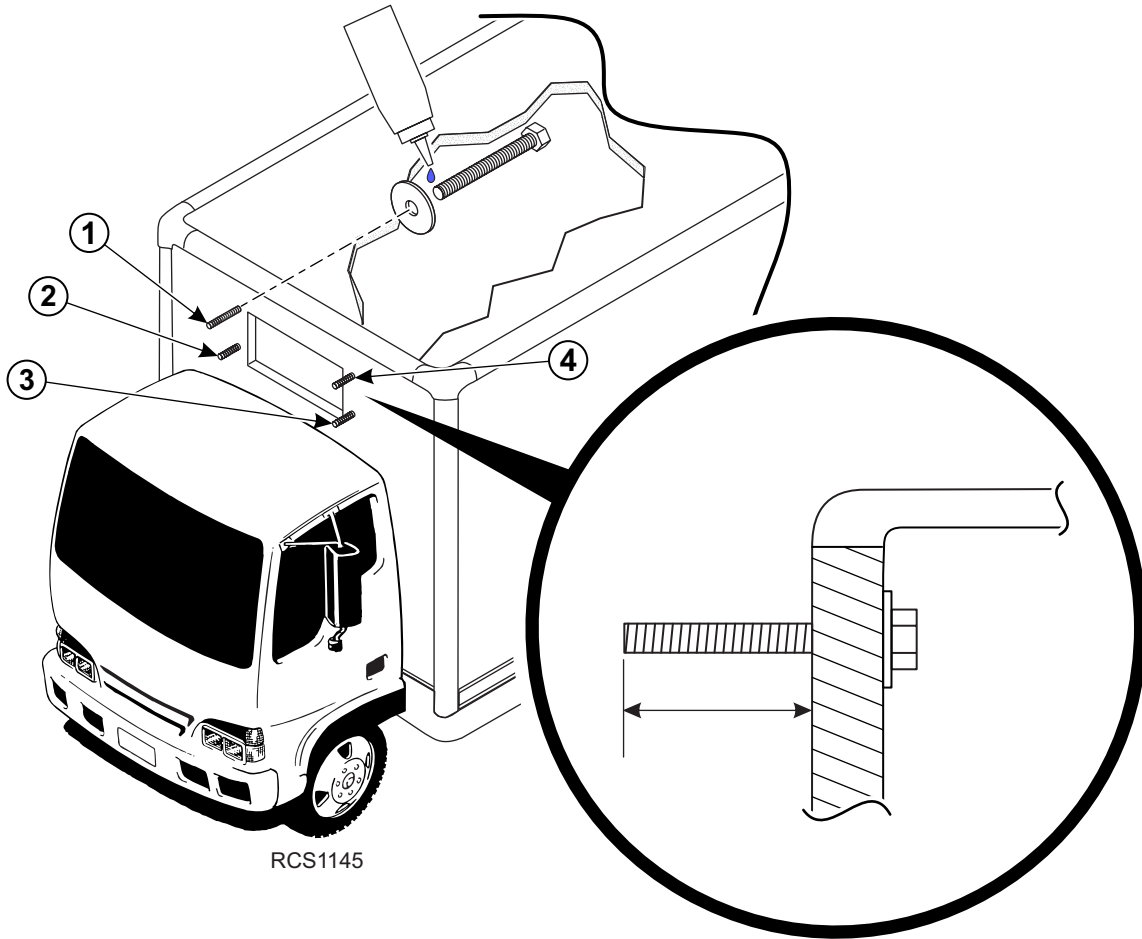


Figure 19. Required Bolt Length Protruding From Cargo Box



RCS1145

Required Bolt Length Protruding From Cargo Box	
1.	72 mm (2.8 in.)
2.	46 mm (1.8 in.)
3.	46 mm (1.8 in.)
4.	46 mm (1.8 in.)

Uncrating Procedures

Important: Safety precautions must be followed. Refer to **Unit Installation Hazards** located in the **Safety Precautions** section of this manual before proceeding.

Thermo King T-90 series units require a 3 point lifting bar to safely install the units. While the current lifting bar will work for installing a T-90 series unit, a new lifting bar was designed with multiple slots for improved unit balance, which are required given the wide variety of balance points for the full range of self-powered truck units. The new lifting bar can be made from the drawings provided in the Dimensions Section of this manual.

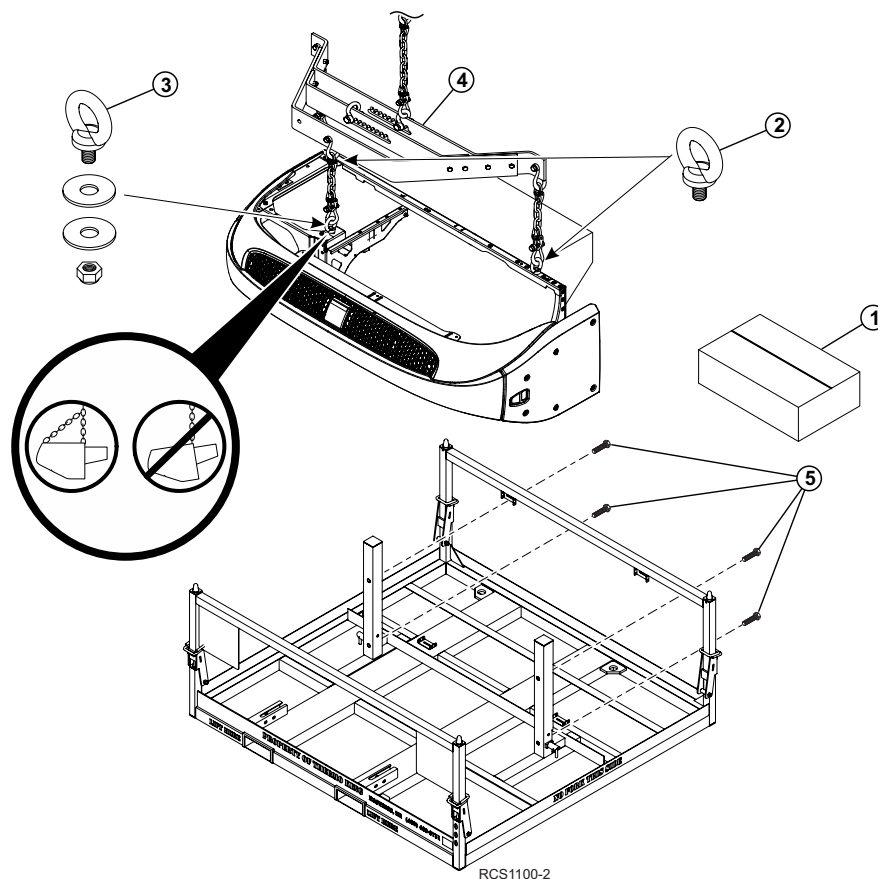
1. Remove kit box(s) shipped with unit.
2. Install M12 forged lifting eyebolts and washers (installer supplied) into the two rear frame locations and tighten securely.
3. Install M12 forged lifting eyebolt, washers and locking nut (installer supplied) into the front balance point location and tighten securely.

Important: Installer supplied lifting eyebolts must be forged steel, 12 mm, 1.75 pitch, with a minimum thread length of 20.5 mm (0.80 in.) long. Substitutions are not acceptable!

4. Use an overhead hoist and 3 point lifting bar attached to the three eyebolts and raise unit only enough to remove slack from the lifting bar chains.
5. Remove the four bolts securing the unit to the mounting posts. **DO NOT** reuse these bolts to install the unit to the truck box.
6. Unlock and remove the two mounting posts from the crate base and carefully raise unit out from crate.

The steel crate can now be broken down for storage or return. See ["Returnable Steel Crate Information," p. 11](#)

Figure 20. Uncrating Unit Shown



Installation Procedures

Important: Safety precautions must be followed. Refer to "Unit Installation Hazards," p. 6 before proceeding.

⚠ Warning

Equipment Damage and Risk of Injury!!

Unit mounting nuts should be installed using hand tools or low speed (maximum 150 RPM) power tools and then torqued properly with a calibrated tool. Never use high speed power tools such as impact guns or impact wrenches, as they overheat mounting hardware and damage the locking feature of the lock nut.

Preferred Installation Method: Thermo King recommends the four (4) factory installed nut plates attached inside the frame along with the correct length hex head grade 5 mounting bolts (installer supplied) be used when installing the unit.

If your installation requires the nut plates be removed, refer to **Alternate Installation Method**.

1. Install the sill gasket (supplied) onto the rear of the unit. The gasket mounts flush to the rear of the condenser frame and the sides fold under the evaporator and interlock with each other to form a rectangle.

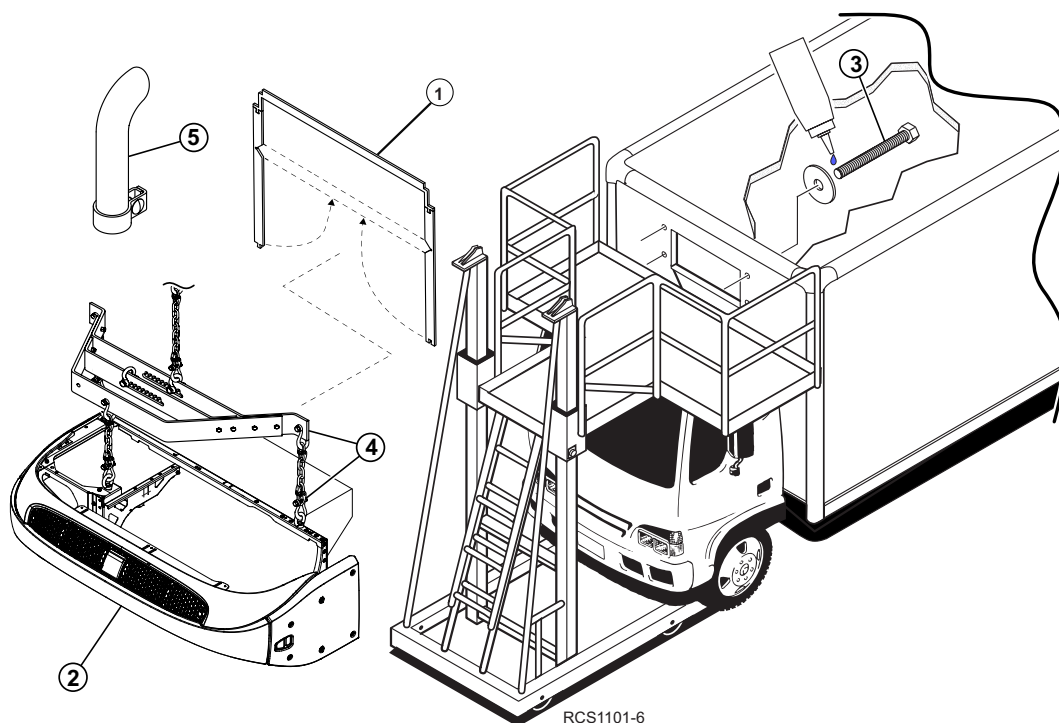
Important: Do not install any compressible washers or other materials between the unit and the truck.

2. Position unit into cargo box opening. Do Not pull on the drain hoses or electrical wires during the installation.
3. From inside the cargo box, insert four (4) correct length mounting bolts (installer supplied) with four (4) 2.00" OD flat washers (supplied) through the front wall of the truck box and into the unit's mounting nuts.
 - a. Apply blue thread locker to all four (4) unit mounting bolts.
 - b. Tighten the mounting bolts evenly and then torque to 81.4 N•m (60 ft-lbs).

Important: A minimum of 2 thread pitches must extend beyond the surface of the nut — more than 2 may damage internal unit components.

4. Disconnect and remove lifting bar and eyebolts from unit.
5. Install exhaust extension tube pointing towards rear of truck and tighten bolt securely.

Figure 21. Typical Unit Installation Shown



Alternate Installation Method: The factory installed nut plates can be removed to accommodate a truck box equipped with mounting studs or T-bolts, provided the following procedures are followed and the additional components (installer supplied) are installed.

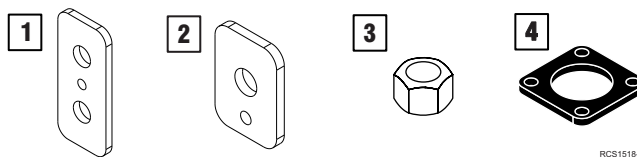
Important: Do not install any compressible washers or other materials between the unit and the truck.

1. Remove unit top covers (if applicable).
2. Remove unit bottom pan.
3. Remove muffler and gasket from unit. Discard gasket.
4. Remove the four (4) nut plates from the unit.
5. Confirm mounting studs or T-bolt threads protrude the require length from cargo box. Refer to “Unit Mounting Bolt Requirements,” p. 31.
6. Install the sill gasket (supplied) onto the rear of the unit. The gasket mounts flush to the rear of the condenser frame and the sides fold under the evaporator and interlock with each other to form a rectangle.
7. Position unit into cargo box opening. Do Not pull on the drain hoses or electrical wires during the installation.
 - a. Apply blue thread locker to all four (4) mounting studs or T-bolt threads.
 - b. Install plates (090400) and nuts (090400) (Purchased Option) onto each threaded stud or T-bolt.
 - c. Tighten nuts evenly and then torque to 81.4 N•m (60 ft-lb).

Important: A minimum of two thread pitches must extend beyond the surface of the nut — more than two may damage internal unit components.

8. Reinstall muffler with a new gasket (331907) (Purchased Option) and torque hardware to 25 N•m (18.3 ft-lb).
9. Disconnect and remove lifting bar and eyebolts from unit.
10. Re-install top covers (if applicable).
11. Re-install bottom pan.
12. Install exhaust extension tube pointing towards rear of truck and tighten bolt securely.

Figure 22. Additional Components Required (Purchased Option)



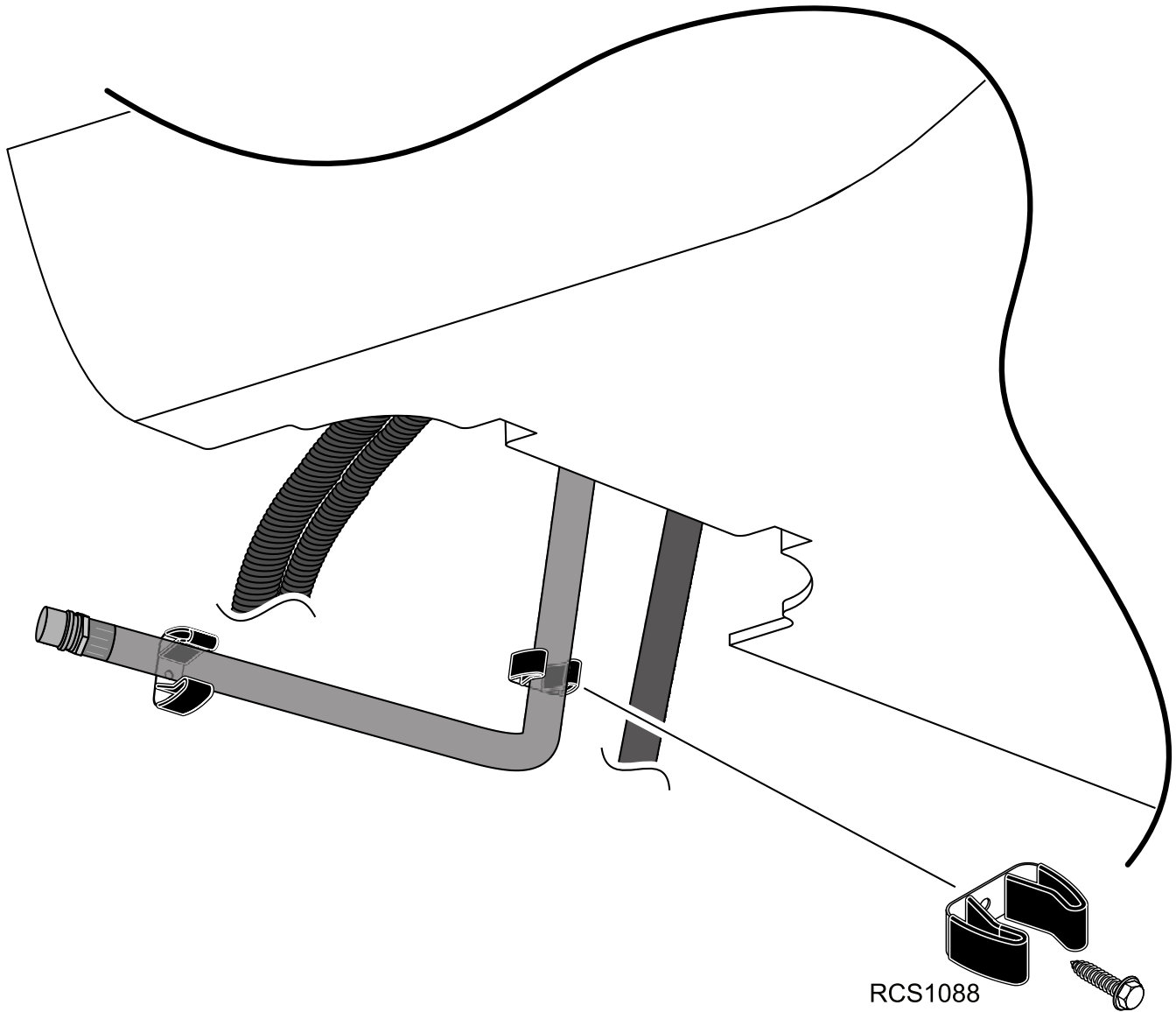
1	Plate	090400	Qty. 1	3	Hex Nut	550287	Qty. 4
2	Plate	090400	Qty. 1	4	Muffler Gasket	331907	Qty. 1

Securing Oil Drain Hose

1. Secure the oil drain hose directly under the unit to the cargo box with the two (2) supplied retaining clips and self tapping screws as shown.

Note: Lower retaining clip should be positioned in a location easily accessible for servicing the unit. Your actual location will depend on the distance between the bottom of unit to top of cab, etc.

Figure 23. Oil Drain Hose Shown Secured Under Unit

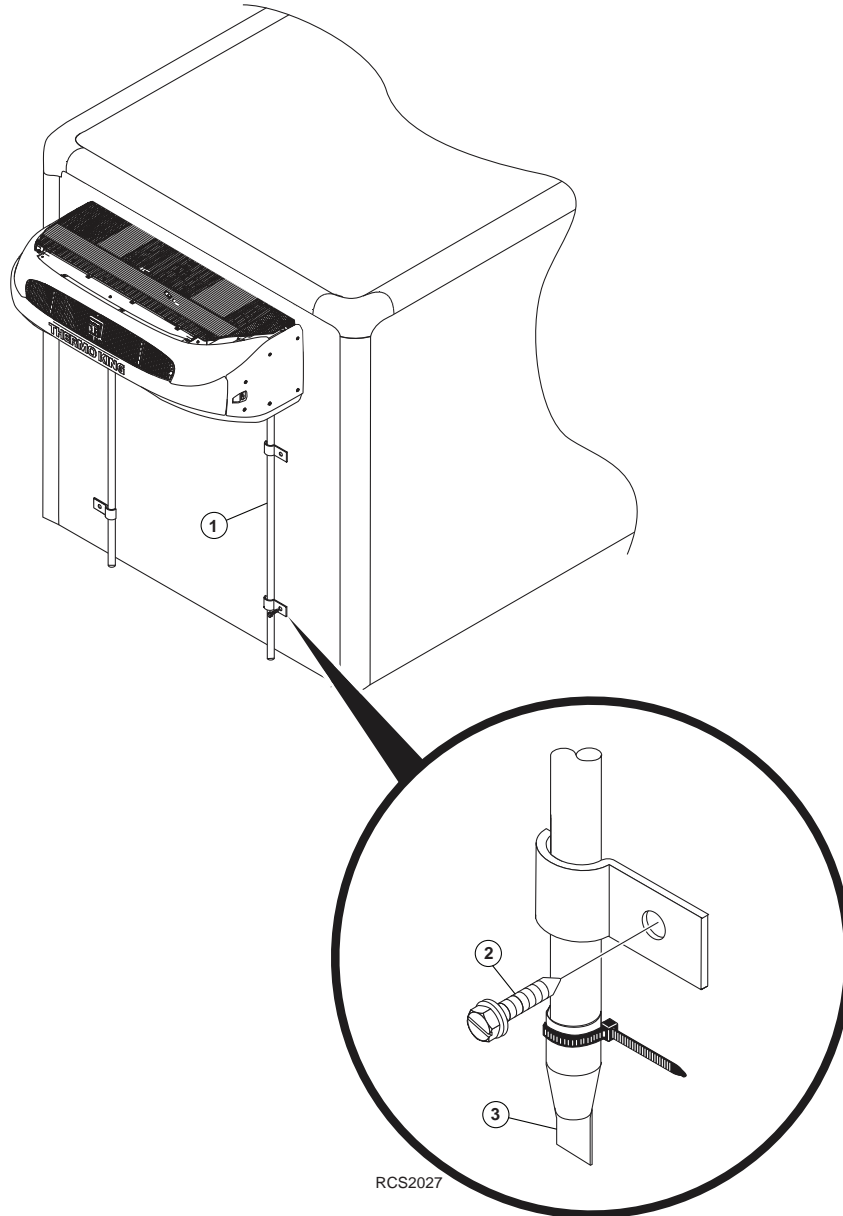


Securing Evaporator Drain Hoses

Note: Evaporator drain hoses must be installed without any sharp bends or kinks to allow for proper water drainage.

1. Route drain hoses from under unit and down the front wall of the truck box.
2. Secure hoses with supplied self tapping screws and clamps.
3. Cut off excess hose and install a check valve securely onto each hose with tie bands.

Figure 24. Evaporator Drain Hose Shown Properly Secured

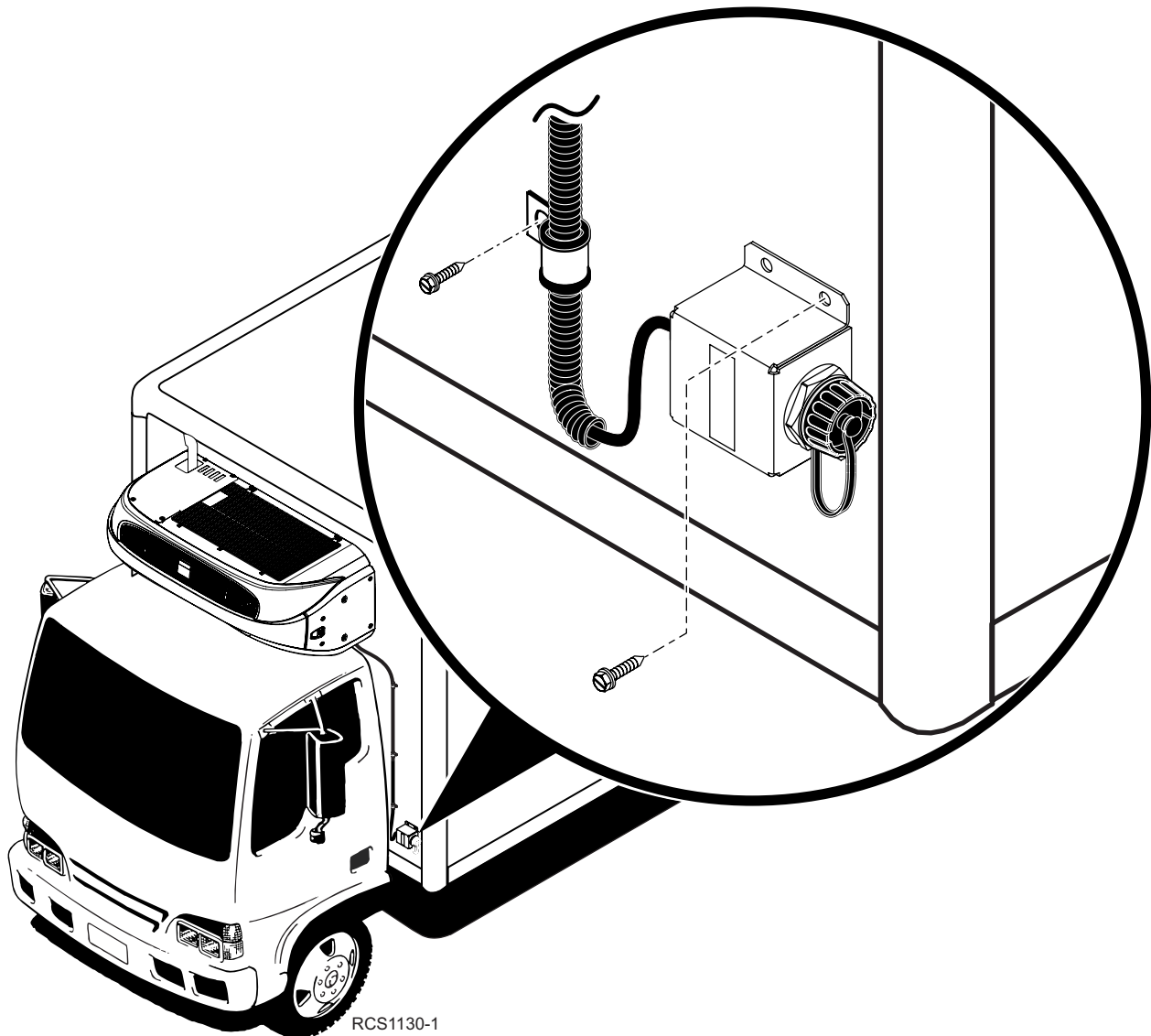


Installing USB Download Port (OPTION)

Note: Installation hardware supplied by installer.

1. Choose an appropriate location to mount the USB Download Port that provides for safe and easy access for connecting the USB Flash Drive.
2. Position the Download Port as shown and attach securely to the truck box with four TEK screws or rivets.
3. Provide a drip loop and secure harness to truck box with clamps and TEK screws or rivets.

Figure 25. Typical Installation Shown



Securing Standby Power Receptacle (OPTION)

Important: Choose an appropriate location to mount the standby power receptacle that does not interfere with the safe operation of the truck while also providing easy access for connecting the power cord. The power cord and plug do not come with the unit and must be sized appropriately. Refer customer to the unit Operator's Manual for standby power requirements.

North American Models

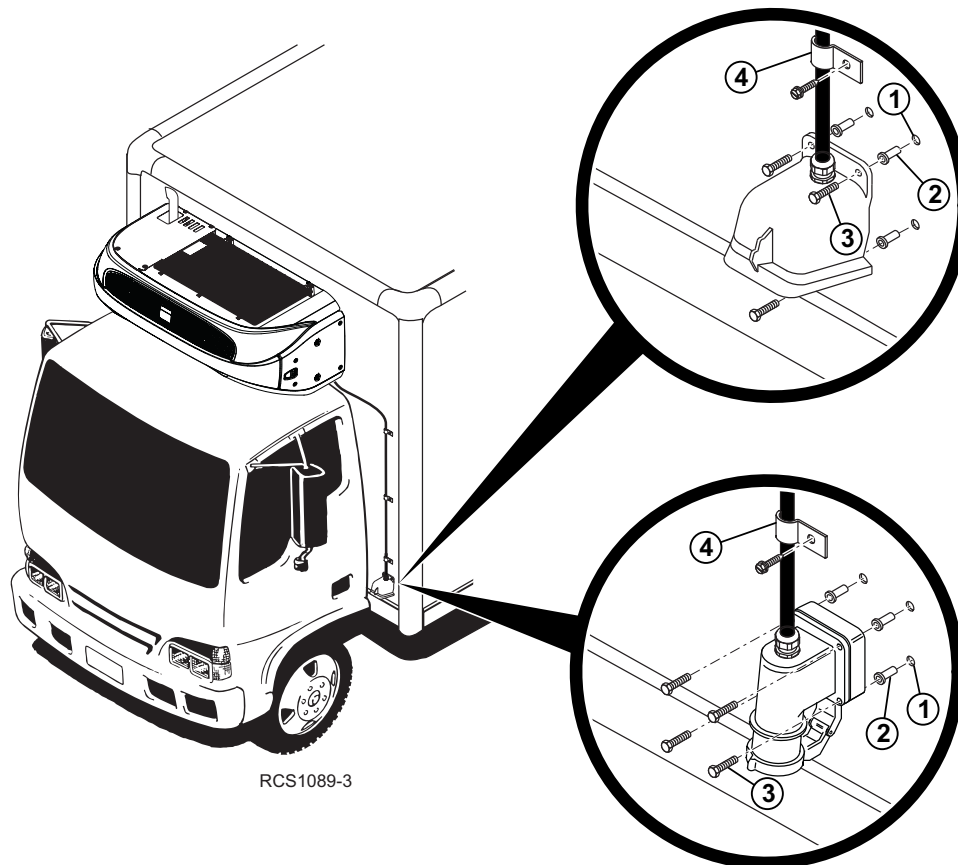
1. Measure and drill three 13 mm (.500 in.) holes into truck box.
2. Insert rubber blind nuts (supplied) into each hole.
3. Attach receptacle with 1/4 x 20 mounting hardware (supplied) and tighten securely.
4. Secure harness to cargo box with clamps and screws (supplied).

International Models

Note: Installer to supply mounting hardware and blind nuts for International model receptacle installation.

1. Measure and drill four 9.5 mm (.375 in.) holes into truck box.
2. Insert rubber blind nuts into each hole.
3. Attach receptacle with 10-32 mounting hardware and tighten securely.
4. Secure harness to cargo box with clamps and screws (supplied).

Figure 26. Typical Installation Shown



Installing HMI Controller

Important: HMI should be installed in an area inside the cab that is accessible to the driver while not interfering with the safe operation of the truck.

INSTALLATION METHODS

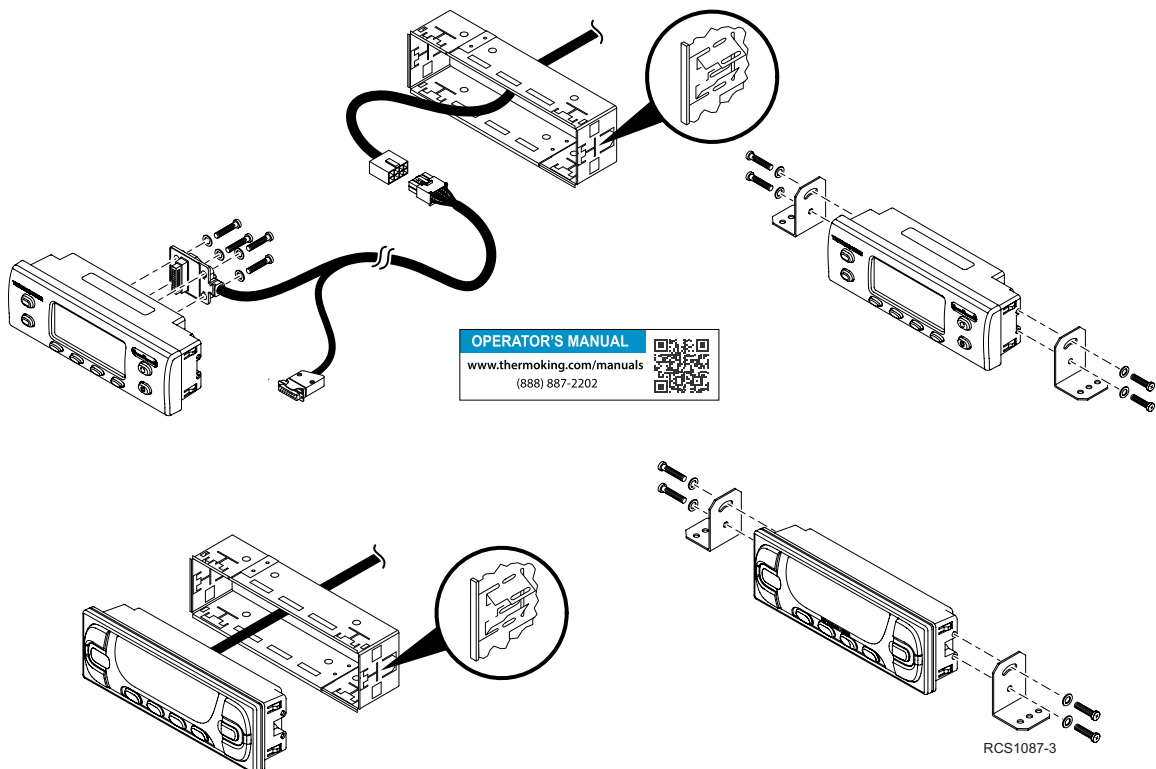
1. Choose installation method that best meets your needs:
 - DIN Mounting** — Supplied DIN (ISO 7736) mounting sleeve allows controller to be installed directly into driver’s panel. Make sure tabs are bent out as shown to secure sleeve into panel opening.
 - L-Brackets** — Supplied L-Brackets allow controller to be installed on top or underneath driver’s panel. Use supplied #8 screws and #8 flat washers to attach L-Brackets to controller. Installer to supply hardware to secure to driver’s panel.
2. Route controller harness from unit to inside cab.

Important: Route and secure controller harness to prevent rubbing, chafing or making contact with sharp, moving or hot components. Allow excess length harness for tilt cab applications. Supplied rubber grommets must be used when routing harness through sheet metal holes.
3. **Premium HMI Controller (Standard)** — Connect adapter harness 8-pin connector to mating connector on controller harness.
 - a. Attach flat plastic adapter harness connector to rear of controller and secure with supplied #10 screws and washers.

Basic HMI Controller (Optional)— Connect controller harness directly to rear of controller until it locks firmly in position. Adapter harness is not used with this controller.

 - a. Lightly pull on harness to confirm it is locked securely.
4. Attach supplied OPERATOR’S MANUAL nameplate near HMI.

Figure 27. Typical Installation Methods Shown



Steel or Aluminum Tank

Important: Safety precautions must be followed. Refer to **Fuel System Component Installation Hazards** located in the **Safety Precautions** section of this manual before proceeding.

Note: The fuel pickup tube supplied in the installation kit will not be needed when also installing an optional Thermo King aluminum fuel tank. The aluminum tank is already equipped with fuel inlet, fuel outlet and vent fittings.

EPA CONFORMANCE: The fuel tank must have a label on the fuel inlet (fill spout) stating "ULTRA-LOW-SULFUR FUEL ONLY". Verify label is present. If not present, order label 93-1184 and install on tank. Reference 40 CFR 1039.104(e)/1039.135

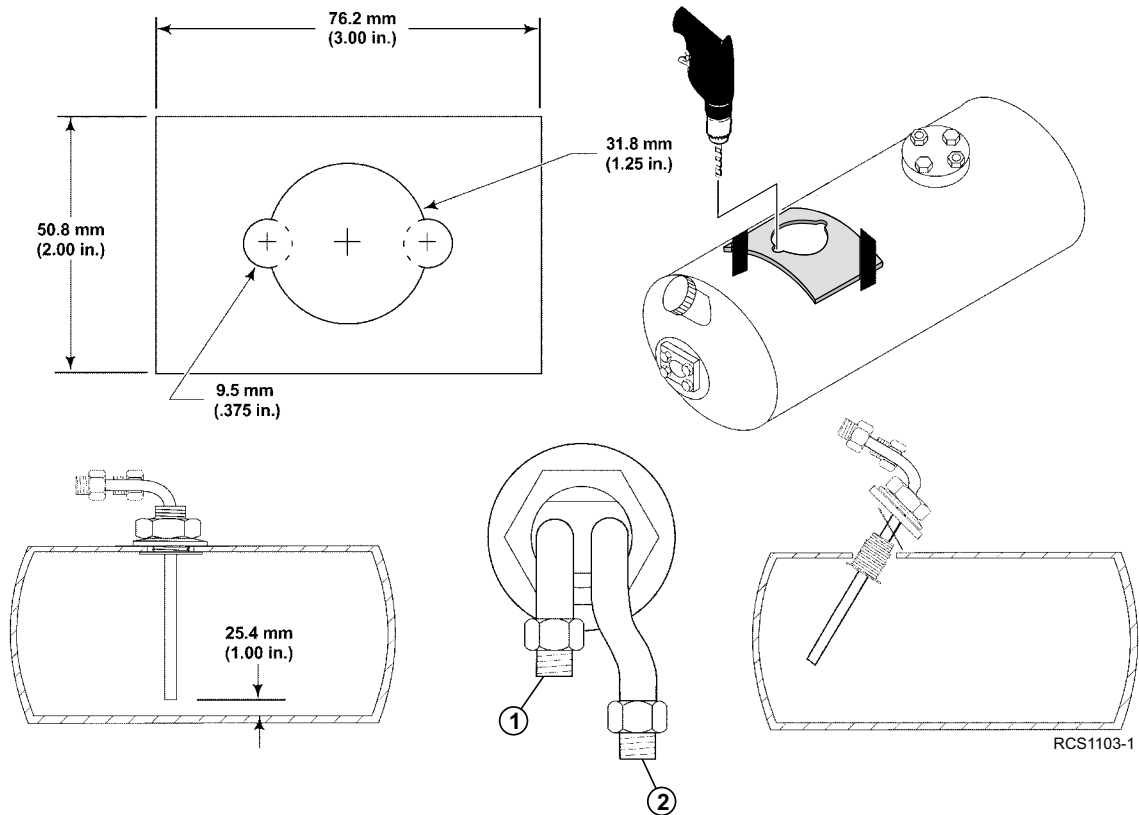
IMPORTANT INSTALLATION TIPS

- BEFORE drilling any holes, check for internal baffles inside the tank.
- PRIOR to installation, remove protective caps from ends of pickup tubes.
- DO NOT apply any type of sealant material to the fuel pickup tube assembly. Doing so will result in plugged fuel lines.

Note: Use a magnet, grease or special hole saws/drills that will minimize debris from entering the fuel tank. Thoroughly clean and flush the tank to remove any debris.

FOLLOW THE INSTALLATION INSTRUCTIONS INCLUDED WITH THE FUEL PICKUP TUBE

Figure 28. Typical Steel or Aluminum Fuel Tank Installation Shown



1.	Return Fitting	2.	Supply Fitting
----	----------------	----	----------------

Plastic Tank

Important: Safety precautions must be followed. Refer to **Fuel System Component Installation Hazards** located in the **Safety Precautions** section of this manual before proceeding.

EPA CONFORMANCE: The fuel tank must have a label on the fuel inlet (fill spout) stating "ULTRA-LOW-SULFUR FUEL ONLY". Verify label is present. If not present, order label 93-1184 and install on tank. Reference 40 CFR 1039.104(e)/1039.135

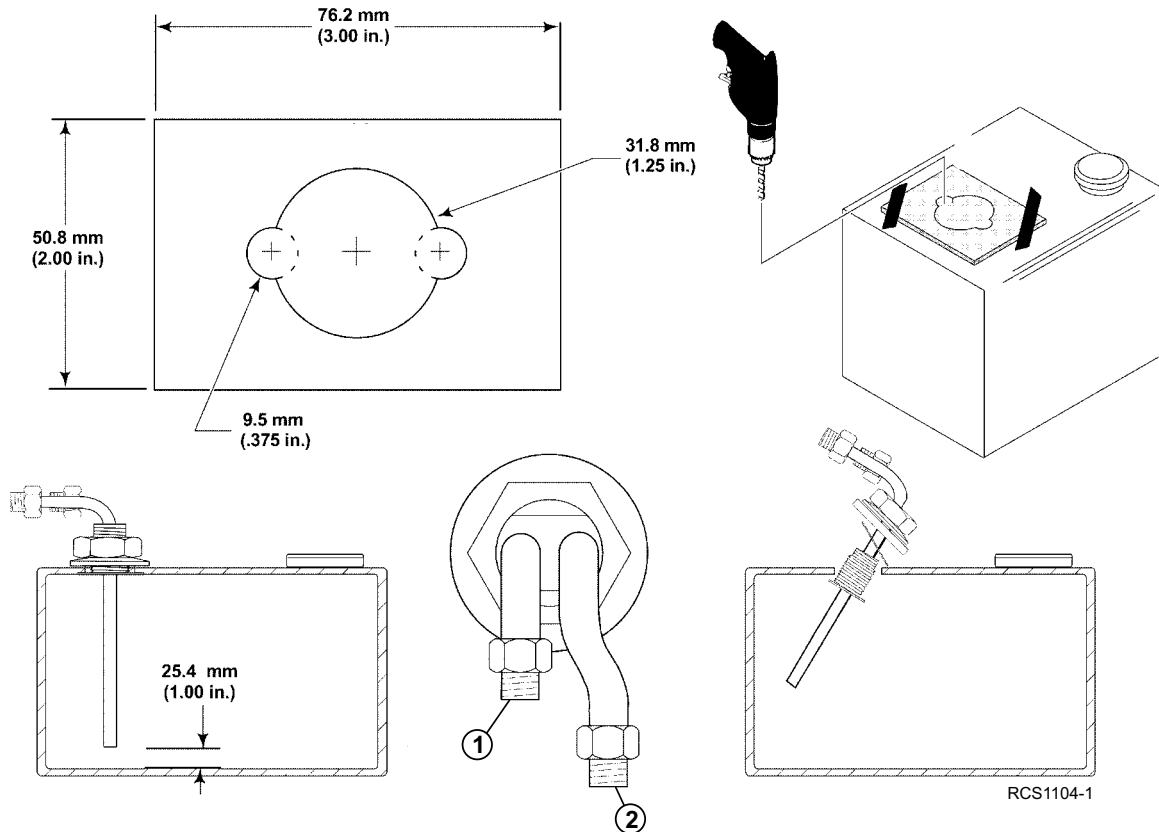
IMPORTANT INSTALLATION TIPS

- BEFORE drilling any holes, check for internal baffles inside the tank.
- PRIOR to installation, remove protective caps from ends of pickup tubes.
- DO NOT apply any type of sealant material to the fuel pickup tube assembly. Doing so will result in plugged fuel lines.

Note: Use a magnet, grease or special hole saws/drills that will minimize debris from entering the fuel tank. Thoroughly clean and flush the tank to remove any debris.

FOLLOW THE INSTALLATION INSTRUCTIONS INCLUDED WITH THE FUEL PICKUP TUBE

Figure 29. Typical Plastic Fuel Tank Installation Shown



1.	Return Fitting	2.	Supply Fitting
----	----------------	----	----------------

Installing Fuel Pump and Fuel Lines

Important: Safety precautions must be followed. Refer to **Fuel System Component Installation Hazards** located in the **Safety Precautions** section of this manual before proceeding.

FUEL PUMP INSTALLATION

1. Install fuel pump as close to fuel tank as possible and no more than 762 mm (30.00 in.) above the fuel in fuel tank. **See important note below.**

a. Secure pump to vehicle's chassis cross members with supplied mounting bracket and hardware.

Important: Some installation will require the fuel pump harness be extended. An **Optional Extended Chassis Harness** is available that includes a 22 ft. long fuel pump harness.

FUEL LINE INSTALLATION

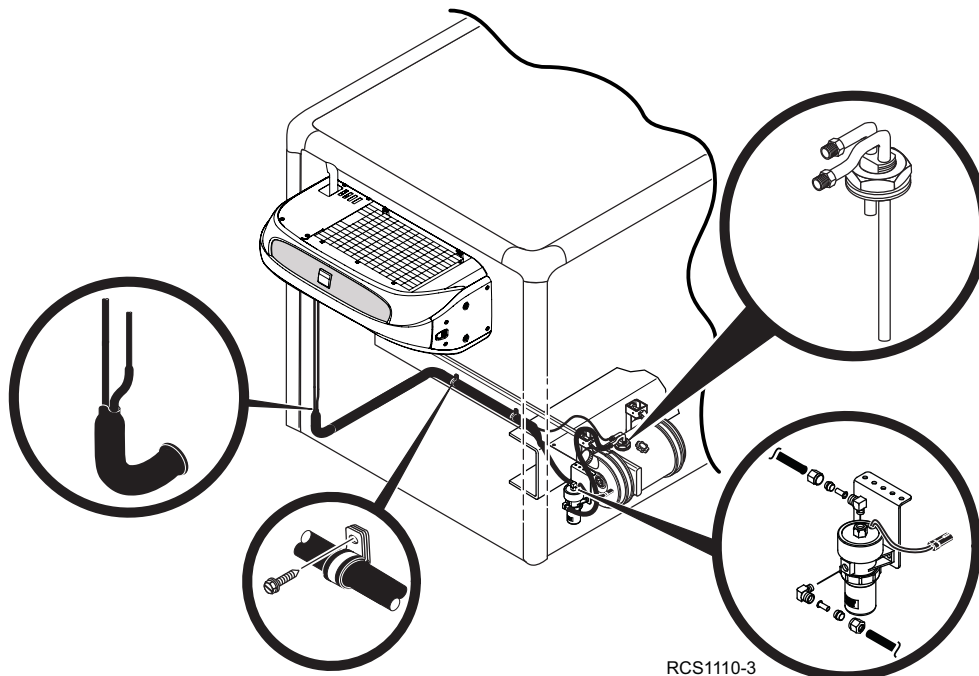
Note: DO NOT connect unit fuel lines to any truck fuel lines.

Always follow these standards when installing and routing fuel lines:

- a. Fuel lines must be routed in split loom protective sleeving with no kinks or sharp bends.
 - b. Rubber grommets must be used when routing fuel lines through sheet metal.
 - c. All fuel lines must be secured with provided clamps.
2. **Supply Line** from tank to pump — Install fuel line from fuel pickup (supply) fitting to fuel pump (IN) fitting.
 3. **Supply Line** from pump to engine — Connect fuel line from fuel pump (OUT) fitting to unit.
 4. **Return Line** from engine to tank — Connect fuel return line from unit to fuel pickup (return) fitting.
 5. Rotate the fuel tank air vent towards the rear of the truck and remove the plastic end cap.

Important: The factory installed fuel tank air vent must be in place and functional for the Thermo King unit's fuel system to operate correctly and for the fuel tank to remain in compliance with Federal Motor Carrier Safety Administration specifications (title 49, paragraph 393.67). A plugged or restricted fuel tank air vent can result in premature damage to the fuel pump and could also cause severe damage to the fuel tank. **NEVER** remove or install any other component in place of the fuel tank air vent.

Figure 30. Typical Installation Shown



RCS1110-3

Battery Connections

Important: Safety precautions must be followed. Refer to **Battery Installation and Cable Routing Hazards** located in the **Safety Precautions** section of this manual before proceeding.

Note: Thermo King units are designed for one 12 volt, group 31 battery. The battery must be suitable for deep cycling, heavy duty, and rated with a minimum of 95 amp/hr.

Important: Battery cables must be routed in split loom protective sleeving with no kinks or sharp bends.

Refer to the illustration on the following page for battery cable and fuse installation details.

Positive Cable Installation

1. At the unit, locate the large black cable marked **POS+**.
 - a. Route cable to battery, cut to proper length and add supplied battery cable lug.
 - b. **DO NOT** connect to battery yet.

In-Line Fuse Installation

2. FOLLOW THE INSTALLATION INSTRUCTIONS (TK 56239).

Fuel Pump Harness Installation

3. Route and connect the fuel pump harness to the fuel pump.

Negative Cable Installation

4. At the unit, locate the large black cable marked **NEG**.
 - a. Route cable to battery, cut to proper length and add battery lug from installation kit.
 - b. Connect cable to the **NEGATIVE** terminal of battery (**Detail B**).
5. All harnesses and battery cables should be neatly routed and secured with provided clamps.
6. Install battery box cover securely (if applicable).

Nameplate Installation

7. Attach supplied nameplate near the battery the unit is connected to (vehicle's battery or battery box).

Auxiliary Electrical Accessories

Thermo King does not recommend adding any auxiliary electrical accessories to the electrical system of a T-590, T-690, T-890 or T-1090 series units equipped with SR-3 controllers and Tier 4 engines unless approved by Thermo King.

TracKing (OPTION)

Units equipped with the factory installed TracKing option requires additional procedures to activate the system. See TracKing Cellular Installation Manual TK 56186 for activation procedures.

Commissioning and PDI Forms

Commissioning Form Overview

All self-powered truck units come with the Commissioning Form (TK 56640) included in the documents package. This form is also available online at Thermo King ReqDirect. By completing the Commissioning Form, the **installer** confirms the installation was done per Thermo King's Installation Manual and the unit operates as it should. Commissioning Forms should be completed for all unit installations and retained by the **installer**.

FORMS ARE LOCATED ON NEXT THREE PAGES

Figure 31. Page 1 of 3 Shown



Self-Powered Truck Installation and Commissioning Form

Section 1 - Equipment Information			
Unit Serial No.	Model:		
Product: Self-Powered Truck	Date in Service:		
Model:	Truck No.:		
Install Date:	Break-in Beginning Hourmeter:		
VIN No.	Break-in Ending Hourmeter:		
OEM:			

Section 2 – Serialized Component Information	
#1 Remote Evap Serial No.:	Add'l Component Part No. / Desc.:
#2 Remote Evap Serial No.:	Add'l Component Part No. / Desc.:
#3 Remote Evap Serial No.:	Add'l Component Part No. / Desc.:
Add'l Component Part No. / Desc.:	Add'l Component Part No. / Desc.:

Section 3 – Unit Installed By			
Installer Name:			
Address:	City:	State:	Zip Code:

Section 4 – Company Registering Unit			
Company Name:			
Address:	City:	State:	Zip Code:

Section 5 – Unit Owned By			
Company Name:			
Address:	City:	State:	Zip Code:

Section 6 – Unit Operated By			
Company Name:			
Address:	City:	State:	Zip Code:

Section 7 - Statement	
Important: This form certifies that the unit has been delivered in satisfactory operating condition. <u>The date of service should not exceed 90 days from date of installation.</u>	
Delivering Co. Signature:	End User Signature:

Further information can be found in the Self-Powered Single Temp Truck Installation Manual TK#56700 and the Multi-Temp Truck Installation Manual TK#56701 available through Thermo King Publications.



Figure 32. Page 2 of 3 Shown

UNIT CHECK LIST

- Visually inspect the unit for transit and handling damage, file claim with delivery carrier.
- Install the unit as outlined in the Thermo King Self-Powered Truck Installation Manual.
- If the unit has a separate fuel tank, add 20 gallons (minimum) of ultra-low sulfur diesel fuel to the tank.

BEFORE STARTING THE UNIT

- Check battery and battery cable installation.
- Inspect fuel line routing checking for rubbing, chaffing or laying on hot surfaces.
- Visually inspect the unit for the following: loose or improperly fitting bolts, brackets, hardware, hose connections, and hose routing.
- Inspect all wiring connections and routing.
- Check defrost drain hoses and drain kazoos.
- Check unit mounting hardware for tightness.
- Check compressor and engine mounts.
- Install refrigeration gauge manifold. (Multi-Temp units only)
- Check engine oil level.
- Check condenser and evaporator section for cleanliness and signs of refrigerant leaks.
- Check belt tensions.

MULTI-TEMP UNITS (REMOTE EVAPORATORS)

- Check evaporator(s) sections for cleanliness.
- Leak test interconnecting tubing.
- Check for damage, loose or missing bolts, and hardware on remote evaporator(s).
- Check for proper installation of drain hoses, drain kazoos and drain tube heater wires.
- Check for properly routed refrigerant tubing and wiring harnesses for remote evaporator(s). Check for properly routed harnesses for remote controller.
- Check for proper installation of remote evaporator guards if equipped.
- Check remote harness wiring connections at pass-through.
- Check wiring, connections, and terminals in the remote evaporator(s).
- Check compartment bulk head(s) for proper fit if equipped.

START AND RUN UNIT (On Multi-Temp units, start only the host unit)

- Check for proper coolant temperature, oil, fuel, or coolant leaks.
- Check alternator output.
- Cycle the unit and ensure the unit functions in the correct modes and the mode indicators are working.
- Confirm engine speeds at high and low speed per maintenance manual.
- Set for continuous run with setpoint at 32 F (0 C) and run the unit to 32 F (0 C).
- Observe and record refrigerant operating pressures in relation to ambient and box temperatures.
- Verify the readings above are correct for the conditions.
- Run unit for 30 minutes at 32 F (0 C). During this period check for correct cycling.
- Allow unit to run and check refrigerant level at a 0 F box temperature (while running in high speed cool per truck installation manual). If unit is a multi-temp, ensure all zones are in cool mode when this check is performed.
- Visually check sight glass.
- Check for proper refrigerant level.

MULTI-TEMP UNITS

- Install the compartment bulk head(s) if equipped.
- Check for correct rotation of remote evaporator fans.
- Check for correct cycling and operation of remote evaporator fans.
- Check the charge per multi-temp unit procedures.

Figure 33. Page 3 of 3 Shown**ALL UNITS**

- Initiate and check defrost operation and termination. Check operation and adjustment of damper door and remote fans. Each zone on multi-temp units must be checked for proper operation.
- Set the unit for Cycle Sentry Operation.
- Check for proper operation of all door switches if equipped.
- Remove the compartment bulk head(s) if equipped.
- Set the unit for continuous run. Choose a setpoint opposite of ambient temperature. Continue to run the unit with the cargo box doors open. Operate the unit until 10 (minimum of 6) hours are shown on the engine run time hourmeter to verify complete break-in. Refer to TT692-1 for additional break-in information.
- Run Pre-Trip Test.

SMARTPOWER (ELECTRIC STANDBY) OPERATIONAL CHECKS IF EQUIPPED

- Test AC electrical contacts and connections by connecting to AC power and running.
- Check for correct electric motor rotation.
- Check compressor clutch operation.
- Adjust setpoint and check for correct modes of operation.
- Power source not available to test AC.

STOP UNIT

- On multi-temp units, leak test interconnecting tubing.
- Check and readjust all belt tensions per maintenance manual instructions.
- Check for oil, fuel, coolant, refrigerant, and exhaust leaks.
- Check engine oil and coolant level.
- Check entire unit for loosened hardware and fittings.
- Check and adjust all skin, door and panels for correct alignment and operation.
- Program per customer required setting.
- Check belt tension.
- Release unit.

WARRANTY REGISTRATION

- Commissioning OEM fills out sections 1, 2, 3, 5, 6 and signs section 7. Form is then returned to dealer where section 4 is completed, section 7 is signed and dealer registers unit in the Thermo King TAVANT Warranty Management System.
- Third Party Installers should ensure an authorized Thermo King Dealer performs a Pre-Delivery Inspection (PDI) and registers the unit in the Thermo King TAVANT Warranty Management System.



THERMO KING

Commissioning and PDI Forms

Pre-Delivery Inspection (PDI) Form Overview

PDI Form (TK 56641) is also included in the documents package of all vehicle powered truck units. This form is also available online at Thermo King ReqDirect. The PDI form is used when the unit installation was performed by someone other than the selling party. By completing the form, the **seller** confirms the unit operates as it should. PDI Forms should be completed for all unit sales and retained by the **seller**.

Completing both the Commissioning and the Pre-Delivery Forms helps assure Thermo King equipment is installed with the highest degree of quality, reliability, and durability to meet or exceed the expectations of our customers resulting in total customer satisfaction.

FORMS ARE LOCATED ON NEXT TWO PAGES

Figure 34. Page 1 of 2 Shown



Self-Powered Truck Pre-Delivery Inspection Form

Section 1 - Equipment Information			
Unit Serial No.	Date in Service:		
Product: Self-Powered Truck	Truck No.:		
Unit Model:	Break-in Beginning Hourmeter:		
Install Date:	Break-in Ending Hourmeter:		
VIN No.	OEM:		

Section 2 – Serialized Component Information	
#1 Remote Evap Serial No.:	Add'l Component Part No. / Desc.:
#2 Remote Evap Serial No.:	Add'l Component Part No. / Desc.:
#3 Remote Evap Serial No.:	Add'l Component Part No. / Desc.:
Add'l Component Part No. / Desc.:	Add'l Component Part No. / Desc.:

Section 3 – Unit Installed By			
Installer Name:			
Address:	City:	State:	Zip Code:

Section 4 – Company Registering Unit			
Company Name:			
Address:	City:	State:	Zip Code:

Section 5 – Unit Owned By			
Company Name:			
Address:	City:	State:	Zip Code:

Section 6 – Unit Operated By			
Company Name:			
Address:	City:	State:	Zip Code:

Section 7 - Statement	
Important: This form certifies that the unit has been delivered in satisfactory operating condition. <u>The date of service should not exceed 90 days from date of installation.</u>	
Delivering Co. Signature:	End User Signature:

Further information can be found in the Self-Powered Single Temp Truck Installation Manual TK#56700 and the Multi-Temp Truck Installation Manual TK#56701 available through Thermo King Publications.



Figure 35. Page 2 of 2 Shown

BEFORE STARTING THE UNIT

- Visually inspect unit for loose or improperly fitting bolts and brackets.
- Ensure hoses are properly routed and hose connections are secure.
- Check electrical connections for tightness and properly mating of battery cables.
- Check fluid levels (engine coolant and engine oil) and adjust as needed.

START AND RUN UNIT

- Run unit for 15 minutes while in cool mode.
- Perform full automated Pre-Trip Test per instructions.
- Observe unit for unusual noises while running and repair as needed.
- Ensure all fans are rotating in the proper direction:
 - Condenser fans should pull air in through the condenser coils.
 - Evaporator blowers should exhaust air through the evaporator outlet.
 - If unit is a multi-temp, check for proper operation of remote evaporator fans.
- Check for any oil, fuel, antifreeze, refrigerant, or exhaust leaks.
- Check unit for alarms generated during the Pre-Trip Test and repair as needed. (Do after performing steps above).
- Allow unit to run and check refrigerant level at a 0°F (-18°C) box temperature (while running in high speed cool per truck installation manual). If unit is a multi-temp, ensure all zones are in cool mode when this check is performed.
- Verify engine break-in procedure was completed by checking unit hourmeter. If it was not completed, operate the unit until 10 (minimum of 6) hours are shown on the engine run time hourmeter to verify complete break-in. Refer to TT692-1 for additional break-in information.
- As unit operates, it is critical that the Certified Technician inspects the unit every few hours and notes pull down rates, frequency, and duration of defrost cycles and general operations of the unit. Pull down times will vary and rates of temperature drop are dependent upon factors such as trailer size, insulation type and thickness and ambient temperature.

SMARTPOWER (ELECTRIC STANDBY) OPERATIONAL CHECKS IF EQUIPPED

- Connect unit to electric standby power and check for proper operation and rotation of electric standby motor, condenser fans and evaporator fans.
 - Note: When not connected to electric standby power, the standby motor contactor was not checked for proper operation during the full Pre-Trip Test performed earlier.

STOP UNIT

- Check for any oil, fuel, antifreeze, refrigerant, or exhaust leaks.
- Check engine oil level and engine coolant level gauge or indicator.
- Check and readjust all belt tensions per maintenance manual instructions.

WARRANTY REGISTRATION

- Commissioning Dealer completes the Warranty Registration process in the Thermo King TAVANT Warranty Management System.



THERMO KING

Notes

Thermo King – by Trane Technologies (NYSE: TT), a global climate innovator – is a worldwide leader in sustainable transport temperature control solutions. Thermo King has been providing transport temperature control solutions for a variety of applications, including trailers, truck bodies, buses, air, shipboard containers and railway cars since 1938. For more information, visit www.thermoking.com or www.tranetechnologies.com.

Thermo King has a policy of continuous product and product data improvements and reserves the right to change design and specifications without notice. We are committed to using environmentally conscious print practices.