



Installation Manual

TriPac® 3

Auxiliary Heating and Cooling Temperature Management System

Rev. D

March 2024

TK 57113-19-IM-EN

TRANE
TECHNOLOGIES

Introduction

This manual was written to assist with the installation of the **Thermo King TriPac 3** Auxiliary Heating and Cooling System onto a typical semi tractor. While not intended to be specific to a particular vehicle, the information in this manual will provide the installer with details to correctly and safely install each of the standard TriPac APU components. The **Thermo King TriPac Installation Standards Guide** (TK 56430) provides more detailed information that must be followed to safely and properly complete the entire installation. Thermo King offers numerous options such as Telematics, Power Inverters, Hourmeters, etc. which have separate installation instructions. These options should be installed simultaneously with the APU when possible to help reduce overall installation time.

Before beginning the installation, the installer should confirm with the customer the location for each of the TriPac components by using the TriPac Installation Questionnaire. The customer should also be made aware of any modifications to existing equipment that may be necessary to complete the installation.

Modifications may include:

- OEM components on the chassis may need to be relocated to accommodate the installation of the TriPac APU.
- Fuel tank may need to be changed to a smaller size.
- TriPac components will be mounted onto the outside of the sleeper.
- Existing storage space under the bunk will be utilized by TriPac components.
- Heating and A/C duct work will be routed and vents will be installed in existing closets or storage compartments.

Due to its complexity, you should not attempt this installation unless you are:

- are an experienced mechanic.
- can safely lift 75 lbs. (34 kilos).
- are EPA Section 609 certified and trained in the repair and maintenance of diesel powered refrigeration systems.
- have a basic understanding of electricity and electrical wiring.
- have the necessary tools and equipment to complete the installation.

This manual is published for informational purposes only. Thermo King makes no representations warranties express or implied, with respect to the information recommendations and descriptions contained herein. Information provided should not be regarded as all-inclusive or covering all contingencies. If further information is required, Thermo King Corporation Service Department should be consulted.

Thermo King's warranty shall not apply to any equipment which has been "so installed, maintained, repaired or altered as, in the manufacturer's judgment, to affect its integrity."

Manufacturer shall have no liability to any person or entity for any personal injury, property damage or any other direct, indirect, special, or consequential damages whatsoever, arising out of the use of this manual or any information, recommendations or descriptions contained herein.

Revision History

Revision A	(07/2023) Released new manual.
Revision B	(08/2023) Corrections to manual.
Revision C	(12/2023) Added Standby Truck Integration Harnesses, reorganized steps, heater fuel pump, and other updates.
Revision D	(03/2024) Added APS nameplate info, heater priming harness info, and other general updates.

Customer Satisfaction Survey

Let your voice be heard!

Your feedback will help improve our manuals. The survey is accessible through any internet-connected device with a web browser.

Scan the Quick Response (QR) code or click [Technical Publications TK Americas Feedback](#) to complete the survey.



Table of Contents

Safety Precautions	7
Danger, Warning, Caution, and Notice	7
General Practices	7
Battery Cable Installation and Routing	8
Refrigerant Hazards	9
Refrigerant Oil Hazards.....	9
First Aid.....	9
Heater Safety Precautions	10
Tips For a Successful Installation.....	11
Before Beginning the Installation	11
APU Installation.....	12
A/C Condenser Installation.....	12
A/C Evaporator Installation.....	12
D2/D4 Heater Installation.....	12
A/C Hose Connections and Routing	13
Engine Coolant Hose Connections and Routing	14
Closed Loop Cooling	14
Electrical Wiring and HMI Controller Installation	14
TriPac 3 Component Dimensions.....	15
APU Assembly	15
Condenser Assembly	20
Evaporator/MAC Assembly (brackets as shipped).....	21
Evaporator/MAC Assembly (brackets as installed)	22
MAC Controller	23
Standard Heater	25
High Output Heater (Option)	25
Telematics Module (Option)	26
HMI.....	27
Required Tools and Additional Supplies.....	28
Typical Component Locations	29
TriPac 3 Components with Truck Coolant Integration	30
TriPac 3 Components with Optional Closed Loop Cooling	31
APU Installation	32
Standard Installation Method – Mounting Claws.....	32
Exhaust Pipe Installation	34
Standard Short Exhaust Tailpipe	34
Optional Exhaust Extension	34



A/C Condenser Installation	35
A/C Receiver Drier Installation	37
A/C Evaporator / MAC Installation	38
Preferred Location – Flush with Front Bulkhead.....	38
Alternative Location – Centered Under Bunk	40
MAC Remote Installation	42
D2/D4 Heater Installation	43
Heater Location.....	43
Drilling Hole In Floor	43
Heater Subassembly and Installation	45
Exhaust and Combustion Air Intake Routing	46
Exhaust and Combustion Air Intake Installation	47
D2/D4 Heater Duct Installation	48
Duct Locations.....	48
Installation Procedures.....	49
A/C Duct and Vent Installation	51
A/C Vent Locations.....	51
Installation Procedures.....	51
A/C Hose Installation	53
A/C System Evacuation and Leak Check Procedures	55
Evacuation Procedures.....	55
Leak Check Procedures.....	55
Main Harness Installation	57
HMI Controller Installation	58
Heater Fuel Pump Connections	60
Fuse Holder and APU Battery Connections	61
HMI Flash Loading Procedures	63
A/C Wiring Installation	64
Standby Truck Integration Harness without Switch (Option)	65
Standby Truck Integration Harness with Switch (Option)	66
Fuel Pickup Tube Installation	67
Preferred Installation – Optional Adapter Plate (100379).....	67

Alternative Installation – Drilling Hole In Fuel Tank.....	69
Heater Fuel Pump and Fuel Line Installation.....	71
L-Bracket Installation Procedures.....	71
Fuel Tank Bracket Installation Procedures.....	71
Fuel Line Installation Procedures.....	71
APU Fuel Line Installation.....	73
Tractor Coolant Hose Installation.....	74
Preferred Installation – APU Coolant Hoses Tee’d Directly Into Tractor’s Heater Hoses.....	74
Coolant Hose Routing and Connections.....	74
Installation Procedures.....	74
Alternative Installation – APU Coolant Hoses Attached Directly To Fittings On Tractor’s Engine.....	76
Coolant Hose Routing and Connections.....	76
Installation Procedures.....	76
Arctic Switch (Option).....	78
Installation Procedures.....	78
Priming The Heater Fuel System (Heat Option).....	80
OPTION 1: Priming Heater Fuel Pump (Modify Heater Priming Harness 2041144).....	81
OPTION 2: Priming Heater Fuel Pump (Harness 2041144 and Jumper Harness 2043233).....	83
OPTION 3: Priming Heater Fuel Pump (Priming Harness 2043232).....	85
OPTION 4: Priming Heater Fuel Pump (EasyScan Tool 2043228).....	87
H33A – Air Heater Fuel Priming.....	88
ConnectedSuite (Option).....	91
Installation Best Practices.....	91
Installation Procedures.....	92
ConnectedSuite™ Activation Procedures.....	94
Heater Start-Up Procedures.....	95
Connecting Diagnostic Tool.....	95
A/C System Charging and APU Engine Start-up Procedures.....	96
Adding Refrigerant Charge.....	96
APU Engine Start-up Procedures.....	97
Bleeding the Standard Cooling System.....	97
Bleeding the Optional Closed Loop Cooling System.....	99
Unit Setup Procedures.....	101
Opening WinTrac.....	101
Unit Information.....	103



Unit Setup	104
Set Clock	107
Run-in Test	108
Installing Nameplates (ATD Units Only)	110
System Check List	111

Safety Precautions

Danger, Warning, Caution, and Notice

Thermo King recommends that all service be performed by a Thermo King dealer and to be aware of several general safety practices.

Safety advisories appear throughout this manual as required. Your personal safety and the proper installation of this unit depend upon the strict observance of these precautions.

⚠ DANGER

Indicates an imminently hazardous situation which, if not avoided, will result in death or serious injury.

⚠ WARNING

Indicates a potentially hazardous situation which, if not avoided, could result in death or serious injury.

⚠ CAUTION

Indicates a potentially hazardous situation which, if not avoided, could result in minor or moderate injury and unsafe practices.

NOTICE

Indicates a situation that could result in equipment or property-damage only accidents.

General Practices

⚠ Danger**Asphyxiation Hazard!**

When a diesel powered TriPac APU is installed under the cab, behind truck fairings, skirting, etc., the diesel exhaust outlet must be routed out to an open area to prevent exhaust fumes from entering the passenger compartment which could result in carbon monoxide poisoning or death by asphyxiation.

⚠ Danger**Hazard of Explosion!**

Never apply heat to a sealed refrigeration system or container. Heat increases internal pressure, which might cause an explosion resulting in death or serious injury.

⚠ Danger**Hazardous Gases - Personal Protective Equipment (PPE) Required!**

Refrigerant in the presence of an open flame, spark, or electrical short produces toxic gases that are severe respiratory irritants which can cause serious injury or possible death. When working with or around hazardous chemicals, ALWAYS refer to the applicable Material Data Safety Sheets (MSDS) and OSHA/GHS (Global Harmonized System of Classification and Labelling of Chemicals) guidelines for information on allowable personal exposure levels, proper respiratory protection, and handling instructions.

⚠ Danger**Refrigerant Vapor Hazard!**

Do not inhale refrigerant. Use caution when working with refrigerant or a refrigeration system in any confined area with a limited air supply. Refrigerant displaces air and can cause oxygen depletion, resulting in suffocation and possible death. When working with or around hazardous chemicals, ALWAYS refer to the applicable Material Data Safety Sheets (MSDS) and OSHA/GHS (Global Harmonized System of Classification and Labelling of Chemicals) guidelines for information on allowable personal exposure levels, proper respiratory protection, and handling instructions.



⚠ Danger

Risk of Injury!

Keep your hands, clothing, and tools clear of fans and/or belts when working on a unit that is running or when opening or closing compressor service valves. Loose clothing might entangle moving pulleys or belts, causing serious injury or possible death.

⚠ Warning

Hazard of Explosion!

Never close the compressor discharge service valve when the unit is operating. Never operate the unit with the discharge valve closed (front seated). This condition increases internal pressure, which can cause an explosion.

⚠ Warning

Personal Protective Equipment (PPE) Required!

Always wear goggles or safety glasses and proper PPE when working on a unit. Refrigerant liquid, oil, and battery acid can permanently damage your eyes. When working with or around hazardous chemicals, ALWAYS refer to the applicable Material Data Safety Sheets (MSDS) and OSHA/GHS (Global Harmonized System of Classification and Labelling of Chemicals) guidelines for information on allowable personal exposure levels, proper respiratory protection, and handling instructions.

⚠ Warning

Equipment Damage and Risk of Injury!

Never drill holes into the unit unless instructed by Thermo King. Holes drilled into high voltage cables could cause an electrical fire, severe personal injury, or even death.

⚠ Warning

Risk of Injury!

When using ladders to install or service refrigeration systems, always observe the ladder manufacturer's safety labels and warnings. A work platform or scaffolding is the recommended method for installations and servicing.

📌 Notice

Equipment Damage!

All unit mounting bolts must be installed, be the correct length for their application, and torqued to specifications. Missing bolts, incorrect bolt lengths and improper torque specifications can damage equipment and void the warranty.

Battery Cable Installation and Routing

⚠ Warning

Hazard of Explosion!

Improperly installed battery cables could result in a fire, explosion, or injury. Battery cables must be installed, routed, and secured properly to prevent them from rubbing, chaffing, or making contact with hot, sharp, or rotating components.

⚠ Warning**Fire Hazard!**

Do not attach fuel lines to battery cables or electrical harnesses. This has the potential to cause a fire and could cause serious injury or death.

⚠ Warning**Hazard of Explosion!**

Always cover battery terminals to prevent them from making contact with metal components during battery installation. Battery terminals grounding against metal could cause the battery to explode.

⚠ Caution**Hazardous Service Procedures!**

Set all unit electrical controls to the OFF position before connecting battery cables to the battery to prevent the unit from starting unexpectedly and causing personal injury.

🔒 Notice**Equipment Damage!**

Do not connect other manufacturers' equipment or accessories to the unit or to the Thermo King batteries unless approved by Thermo King. Failure to do so can result in severe damage to equipment and void the warranty.

Refrigerant Hazards**⚠ Warning****Personal Protective Equipment (PPE) Required!**

Refrigerant in a liquid state evaporates rapidly when exposed to the atmosphere, freezing anything it contacts. Wear butyl lined gloves and other clothing and eye wear when handling refrigerant to help prevent frostbite. When working with or around hazardous chemicals, ALWAYS refer to the applicable Material Data Safety Sheets (MSDS) and OSHA/GHS (Global Harmonized System of Classification and Labelling of Chemicals) guidelines for information on allowable personal exposure levels, proper respiratory protection, and handling instructions.

Refrigerant Oil Hazards**⚠ Warning****Personal Protective Equipment (PPE) Required!**

Protect your eyes from contact with refrigerant oil. The oil can cause serious eye injuries. Protect skin and clothing from prolonged or repeated contact with refrigerant oil. To prevent irritation, wash your hands and clothing thoroughly after handling the oil. Rubber gloves are recommended. When working with or around hazardous chemicals, ALWAYS refer to the applicable Material Data Safety Sheets (MSDS) and OSHA/GHS (Global Harmonized System of Classification and Labelling of Chemicals) guidelines for information on allowable personal exposure levels, proper respiratory protection, and handling instructions.

First Aid**REFRIGERANT**

- **Eyes:** For contact with liquid, immediately flush eyes with large amounts of water and get prompt medical attention.



Safety Precautions

- **Skin:** Flush area with large amounts of warm water. Do not apply heat. Remove contaminated clothing and shoes. Wrap burns with dry, sterile, bulky dressing to protect from infection. Get prompt medical attention. Wash contaminated clothing before reuse.
- **Inhalation:** Move victim to fresh air and use CPR (cardio pulmonary resuscitation) or mouth-to-mouth resuscitation to restore breathing, if necessary. Stay with victim until emergency personnel arrive.
- **Frost Bite:** In the event of frost bite, the objectives of First Aid are to protect the frozen area from further injury, warm the affected area rapidly, and to maintain respiration.

REFRIGERANT OIL

- **Eyes:** Immediately flush with large amounts of water for at least 15 minutes. Get prompt medical attention.
- **Skin:** Remove contaminated clothing. Wash thoroughly with soap and water. Get medical attention if irritation persists.
- **Inhalation:** Move victim to fresh air and use CPR (cardio pulmonary resuscitation) or mouth-to-mouth resuscitation to restore breathing, if necessary. Stay with victim until emergency personnel arrive.
- **Ingestion:** Do not induce vomiting. Immediately contact local poison control center or physician.

ENGINE COOLANT

- **Eyes:** Immediately flush with large amounts of water for at least 15 minutes. Get prompt medical attention.
- **Skin:** Remove contaminated clothing. Wash thoroughly with soap and water. Get medical attention if irritation persists.
- **Ingestion:** Do not induce vomiting. Immediately contact local poison control center or physician.

ELECTRICAL SHOCK

Take IMMEDIATE action after a person has received an electrical shock. Get quick medical assistance, if possible.

The source of the shock must be quickly stopped, by either shutting off the power or removing the victim. If the power cannot be shut off, the wire should be cut with a non-conductive tool, such as a wood-handle axe or thickly insulated cable cutters. Rescuers should wear insulated gloves and safety glasses, and avoid looking at wires being cut. The ensuing flash can cause burns and blindness.

If the victim must be removed from a live circuit, pull the victim away with a non-conductive material. Use wood, rope, a belt or coat to pull or push the victim away from the current. DO NOT TOUCH the victim. You will receive a shock from current flowing through the victim's body. After separating the victim from power source, immediately check for signs of a pulse and respiration. If no pulse is present, start CPR (cardio pulmonary resuscitation). If a pulse is present, respiration might be restored by using mouth-to-mouth resuscitation. Call for emergency medical assistance.

Heater Safety Precautions

Important: Correct installation of this heater is necessary to ensure safe and proper operation. **BEFORE** installing the heater, thoroughly read and understand this manual and the heater manufacturer's manuals included with the heater.

⚠ Danger

Hazard of Explosion or Fire!

Failure to follow these instruction could cause a explosion or fire resulting in serious or fatal injury.

- Heater must be turned off while re-fueling.
- Install heater so it will maintain a minimum distance of 2" from any flammable or heat sensitive material.
- Install the exhaust system so it will maintain a minimum distance of 2" from any flammable or heat sensitive material.
- Stored items in may shift while vehicle is in operation and should be secured adequately to prevent contact with the heater.
- Use a protective air intake grille on the air inlet side of the heater to prevent objects from being sucked in.
- The heater must only be operated when the maintenance flap is closed and the outlet hood is mounted in position.
- Do not install heater in enclosed areas where combustible fumes may be present.
- Do not store or transport combustibles (road flares, starting fluids, fuel containers, oil cans, spray cans, gas cartridges, fire extinguishers, cleaning rags, clothing, paper, etc.) in the same compartment as the heater.
- Ensure that the fuel system is intact and there are no leaks.
- Do not route electrical wires, harness or battery cables together with fuel lines.

⚠ Danger

Asphyxiation Hazard!

The correct installation of the exhaust and combustion air intake hoses is extremely important to prevent carbon monoxide poisoning or asphyxiation.

- Route the heater exhaust so that exhaust fumes can not enter into the passenger compartments.
- Ensure an air tight seal will be maintained between the heater and mounting surface and at any exhaust connection points.
- Ensure that heating air supply is taken from an area where poisonous gases will not be present.
- When the heater is installed in a enclosed compartment separate from the evaporator, a inlet for return air must be installed to provide the heater with a fresh air supply.
- If running exhaust components through an enclosed compartment, ensure that it is vented to the outside.
- The enclosed compartment must be free of any holes, cracks or rusted out areas to prevent fumes from entering into the passenger compartment.
- The heater must be installed flush with the floor pan (i.e. sheet metal, fiberglass, etc.) to ensure proper sealing of the mounting plate and gasket.
- The heater must not be operated in closed areas such as garages, buildings, warehouses, etc.
- Do not inhale exhaust fumes.

📄 Notice

Equipment Damage!

Disconnect the heater harness at the battery before welding on the truck chassis to prevent damage to the electronic HMI controller.

Tips For a Successful Installation

Before Beginning the Installation

Important: Proper installation of each component onto the vehicle is critical! Refer to the Thermo King TriPac Installation Standards Guide (TK 56498) before beginning the installation. Adhering to the installation standards will help assure the components are installed correctly and the system operates as designed. It is the responsibility of the installer to follow these standards.

- Read this manual to understand where components are to be located and how they are to be installed.
-
- Thermo King offers numerous options such as Telematics, Power Inverters, Hourmeters, etc. which have separate installation instructions. These options should be installed simultaneously with the APU when possible to help reduce overall installation time.
- Review the TriPac component drawings for important minimum/maximum dimensions and clearances that must be taken into consideration when installing these components.
- Open all TriPac kits and inspect contents before beginning installation.
- Verify tools and special equipment required for the installation are available and in good working condition.
- Review component location diagram and discuss with the customer where each component will be installed on the truck.

Safety Precautions

- It is recommended that one person performs the installation of all the components **outside** the sleeper while a second person installs all the components **inside** the sleeper. This will help minimize any damage to the sleeper's interior from grease, dirt, etc.

APU Installation

- DO NOT weld on any part of the tractor's frame or drill holes in the top or bottom flanges. Serious structural damage could occur. Consult your chassis manufacturer for further information.
- The APU is designed to be mounted only to the existing frame rails. **NO OTHER MOUNTING IS ACCEPTABLE!**
- Determine the best location for installing the APU on the existing chassis frame rail.
- Safely relocate any components on the chassis frame rail that interfere with the installation of the APU.
- Check clearance around APU before installing.
- The use of a motorcycle/ATV lift or modified floor jack to raise APU into position is recommended.
- Only the supplied spacer blocks and mounting claws must be used to install the APU to the chassis frame rail.
- If different mounting bolts are used they must be Grade 5 and of the correct length. DO NOT cut off excessive length bolts.
- Verify the upper and lower APU mounting bolts are flush with the chassis frame rail before tightening.
- The mounting hardware securing the APU to the tractor's frame must be correctly positioned and torqued using the four-step tightening sequence described in the "APU Installation" section in this manual.
- All APU covers, guards or removable panels must be in place and installed securely while operating the system.

A/C Condenser Installation

- Always keep A/C system fittings capped and sealed until the installation of the refrigeration hoses.
- Determine the best location to mount the condenser onto the exterior of the sleeper.
- Verify all measurements before drilling any mounting holes.
- Verify there is no interference with any OEM electrical wiring, internal supports, etc. before drilling mounting holes.
- Confirm the condenser location does not interfere with the service or operation of existing tractor components.
- Provide protection to the tractor's finish to prevent damage during the installation process.
- Use the stainless steel mounting hardware (supplied in the kit) to mount the condenser coil.
- Use the large fender washers (supplied in kit) inside the sleeper to provide additional support.
- All mounting holes must be sealed with silicone caulking to prevent moisture or fumes from entering the sleeper.

A/C Evaporator Installation

- Always keep A/C system fittings capped and sealed until the installation of the refrigeration hoses.
- Determine the best location for the A/C evaporator inside the sleeper, typically under the bunk.
- Verify there is no interference with any OEM electrical wiring, internal supports, etc. before drilling any mounting holes.
- The evaporator should be mounted directly onto the floor mat inside the sleeper by using the supplied template to locate the drain and mounting holes.
- Always install the drain valves (kazoos) onto evaporator drain tubes securely with hose clamps.
- The A/C vents should be located and installed to provide maximum air circulation in the sleeper such as: LOW (floor level), MEDIUM (above lower bunk level) or HIGH (above upper bunk level).
- All mounting holes must be sealed with silicone caulk to prevent moisture or exhaust fumes from entering the sleeper.
- All edges of access holes made in fiberglass and wood composite floors must be sealed correctly with fiberglass cloth and resin.

D2/D4 Heater Installation

- Determine the best location of the heater inside the sleeper, typically under the bunk. Allow clearance for dismantling for service.

- Install heater so it will maintain a minimum distance of 2.00 inches (50.8 mm) from any heat sensitive or flammable material.
- Heater must be mounted on a flat horizontal surface.
- Heater must be installed flush with the floor pan (i.e. sheet metal, fiberglass, etc.) to ensure proper sealing of the mounting plate and gasket.
- All edges of access holes made in fiberglass and wood composite floors must be sealed correctly with fiberglass cloth and resin.
- Outside air intake and exhaust hoses must be installed correctly for the heater to operate safely.
- Exhaust hose should be mounted slightly downwards to help drain off condensation.
- Install exhaust hose so it will maintain a minimum distance of 2.00 inches (50.8 mm) from any heat sensitive or flammable material.
- Inside air inlet and outlet ducts must be installed correctly for the heater to operate safely.
- Pulse fuel pump must be installed at a 15 to 35 degree angle from horizontal to operate correctly.
- Fuel pickup tube must be installed correctly in the fuel tank or the heater will not operate.
- Fuel line from the pickup tube to the fuel pump to the heater should be routed at a continuous rise.
- Use a hose cutter or sharp knife to cut plastic fuel lines. Do not use a wire cutter as this will pinch the plastic fuel line closed.
- Do not route electrical wires, harness or battery cables together with fuel lines.
- BEFORE operating the optional cabin heater, the fuel lines must be bled of air or damage to the fuel pump will result. See 'Priming the Heater Fuel Pump' chapter in this manual.
 - Heater priming harness 2041144 must be modified to work with the TriPac 3 Series of Espar AS2 D2L /AS2 D4L, AS3 D2L, AM3 D4L heaters.
 - Heater priming harness 2041144 and jumper harness 2043233 can be used together to prime the TriPac 3 Espar AS2 D2L /AS2 D4L, AS3 D2L, AM3 D4L heater fuel system.
 - Heater priming harness 2043232 can be used without jumpers or modifications to prime the TriPac 3 spar AS2 D2L /AS2 D4L, AS3 D2L, AM3 D4L heater fuel system.
 - The Air Heater EasyScan Diagnostic Tool 2043228 is capable of priming the TriPac 3 heater fuel system. See 'Priming the Heater Fuel Pump' chapter in this manual.
- The Air Heater EasyScan Diagnostic Tool (Part Number 2043228) may be used to setup and operate the heater in the run-in mode.

A/C Hose Connections and Routing

- Always keep A/C system fittings capped and sealed until the installation of the refrigeration hoses.
- Only cut refrigerant hoses with the correct hose cutting tool (204-677). NEVER USE A SAW!
- Always use the correct hose fitting tool (204-1045) when assembling refrigeration hoses.
- Always lubricate hose fittings with PAG 100 refrigerant oil (2030502) when assembling to refrigeration hoses.
- Always install and lubricate O-rings with PAG 100 refrigerant oil (2030502) when connecting refrigeration hose fittings to component connection fittings.
- Refrigeration hoses should be installed onto components in such a way as to allow for vibration and movement of the cab. THEY SHOULD NEVER BE STRETCHED TIGHT!
- All refrigeration connections should be tightened securely using two wrenches.
- Always keep refrigeration hoses from rubbing or chafing against sharp metal objects, rotating components or hot components.
- Protective covers or sleeving (installer supplied) for the refrigeration hoses may be required depending on the installation.
- Always install the condenser's receiver drier in the direction indicated by the arrow.
- Thermo King Evacuation Station (204-725) and Evacuation Station Operation and Field Application Instructions (TK-40612) are recommended.
- The oil in the evacuation station vacuum pump should be changed after each use.



Safety Precautions

- The A/C system must be leak free. Check for leaks by using an electronic leak detector.
- The A/C system will be charged with 1.2 to 2.0 bs. (depending on hose lengths) of R134a.

Engine Coolant Hose Connections and Routing

The following steps are for APU's equipped with Tractor Coolant Integration only.

- Coolant hoses should be routed from the APU to the tractor's engine without any sharp bends or kinks.
- Coolant hoses should be installed and routed in such a way as to allow for vibration and movement. **THEY SHOULD NEVER BE STRETCHED TIGHT!**
- Coolant hoses should be protected with supplied plastic sleeving and adequately secured to the chassis with clamps and band wraps.
- Always keep coolant hoses from rubbing or chafing against sharp metal objects, rotating components or hot objects.
- All coolant pipe fittings installed should be of proper material type, (i.e: brass to brass, or copper to copper).
- All coolant fittings should be assembled using pipe thread sealer to prevent leaks.
- Ball type shutoff valves (supplied) should be installed to allow the TriPac cooling system to be closed off and isolated from the tractor's engine cooling system.
- Shutoff valves and fittings must be adequately supported to prevent cracks or leaks from vibration.

Closed Loop Cooling

Do not start the APU's engine without first adding coolant and bleeding all air from the system.

Electrical Wiring and HMI Controller Installation

- Electrical wiring should be installed and routed in such a way as to allow for vibration and movement of the cab. **THEY SHOULD NEVER BE STRETCHED TIGHT!**
- Always keep electrical wiring from rubbing or chafing against sharp metal objects, rotating components or hot objects.
- All electrical wiring should be neatly routed and secured with band wraps or clamps.
- Do not route electrical wires, harness or battery cables together with fuel lines.
- Excess length of battery cables should be cut off to reduce voltage drop.
- Superlube (203-524) or equivalent should be applied to all electrical connections.
- All main power and ground accessory connections must be installed directly on top of the tractor's battery terminal posts and tightened securely. **DO NOT INSTALL UNDER OEM BATTERY CABLES!**
- The HMI should be visible and mounted away from windows, air vents, out of direct sunlight and not touching anything to accurately measure air temperature.

TriPac 3 Component Dimensions

APU Assembly

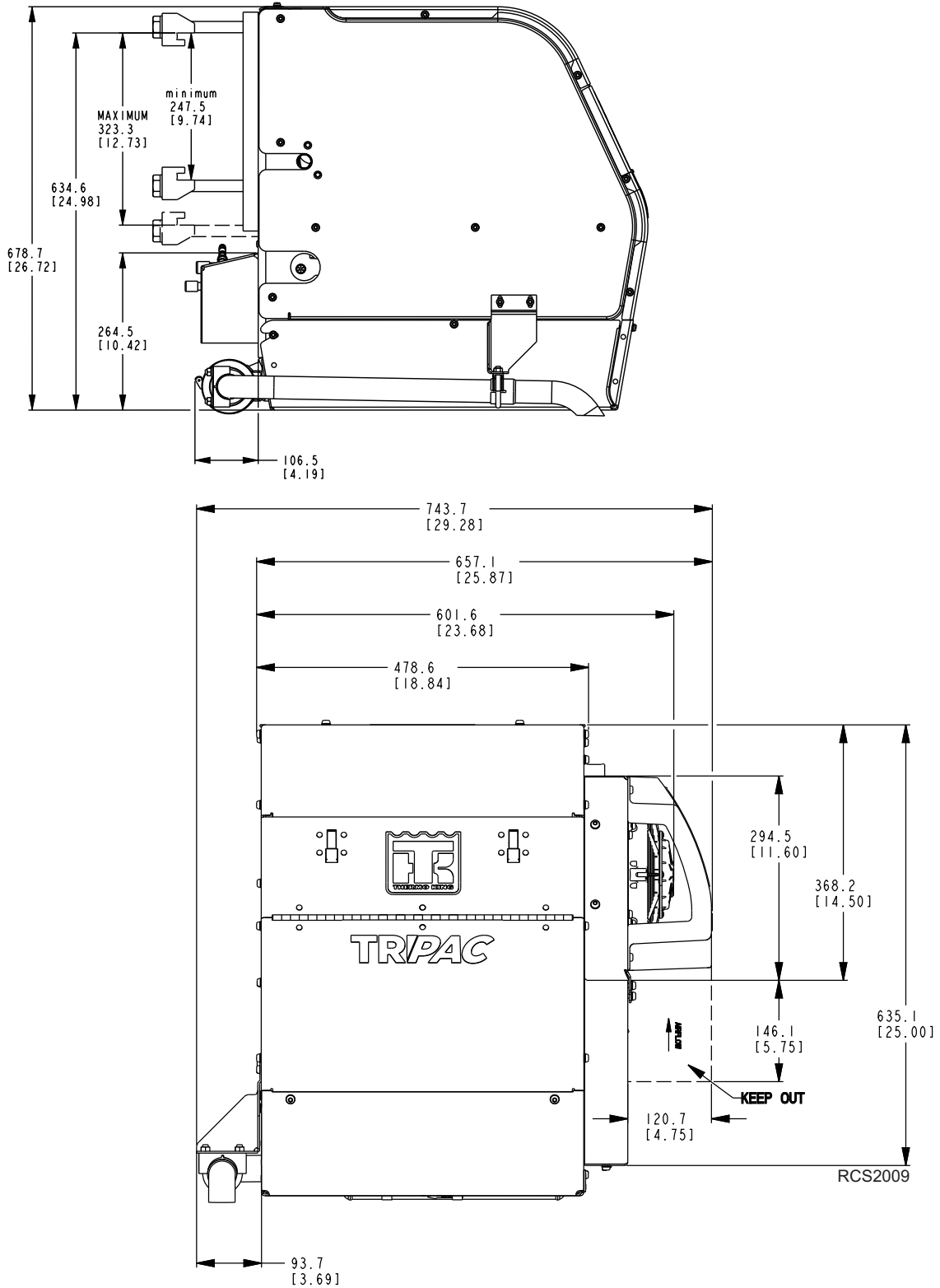



THERMO KING

TriPac 3 Component Dimensions

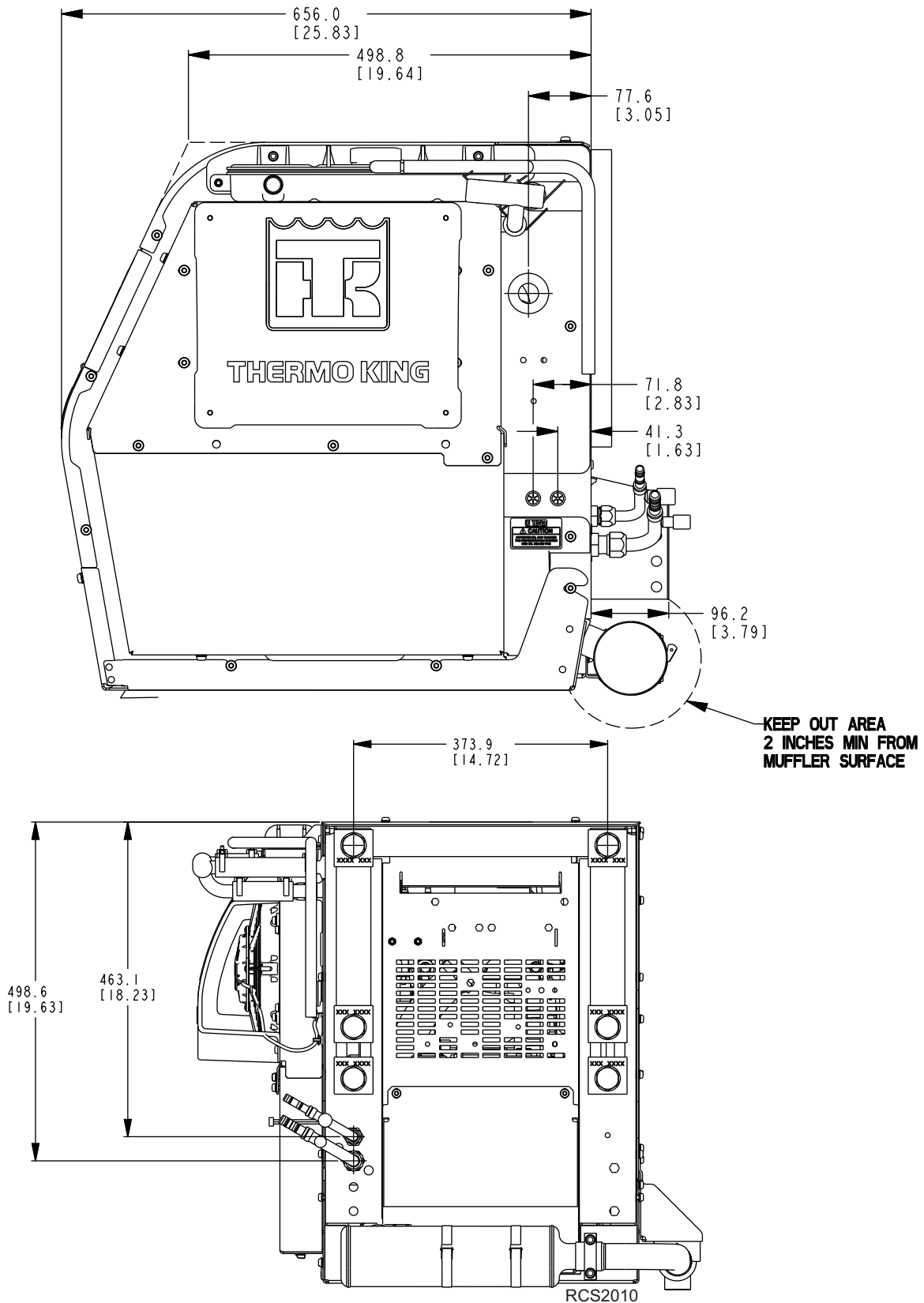
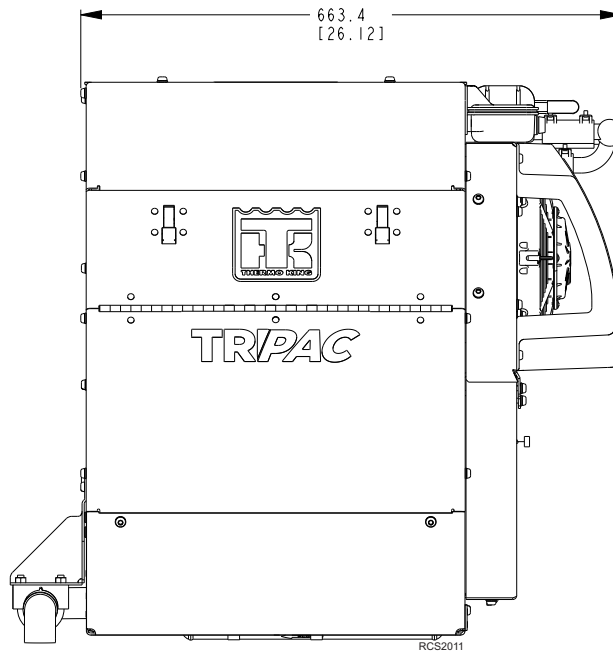

Figure 1. With Expansion Tank for Closed Loop Cooling Option





THERMO KING

TriPac 3 Component Dimensions

Figure 2. APU with ATD (Aftertreatment Device) Option Shown

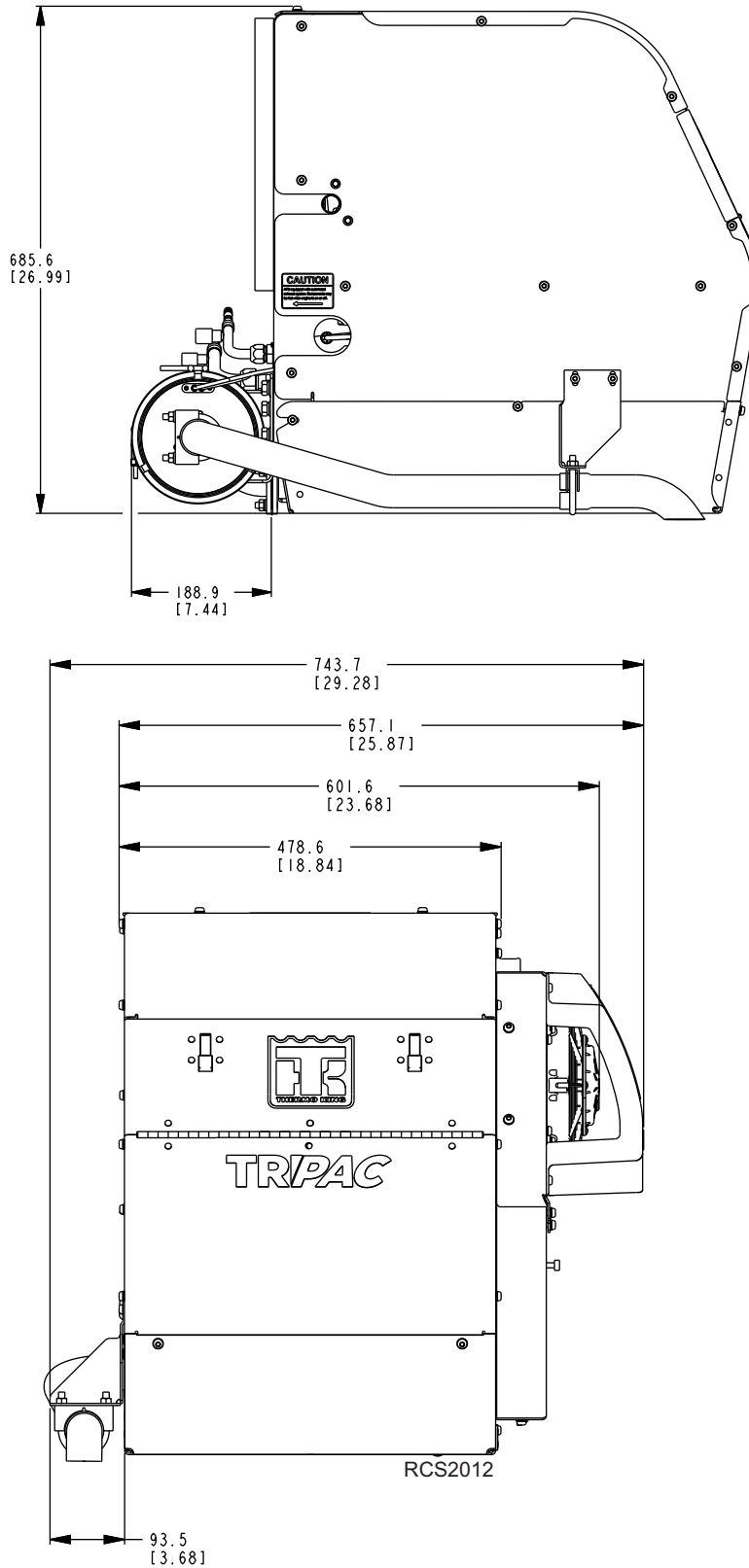
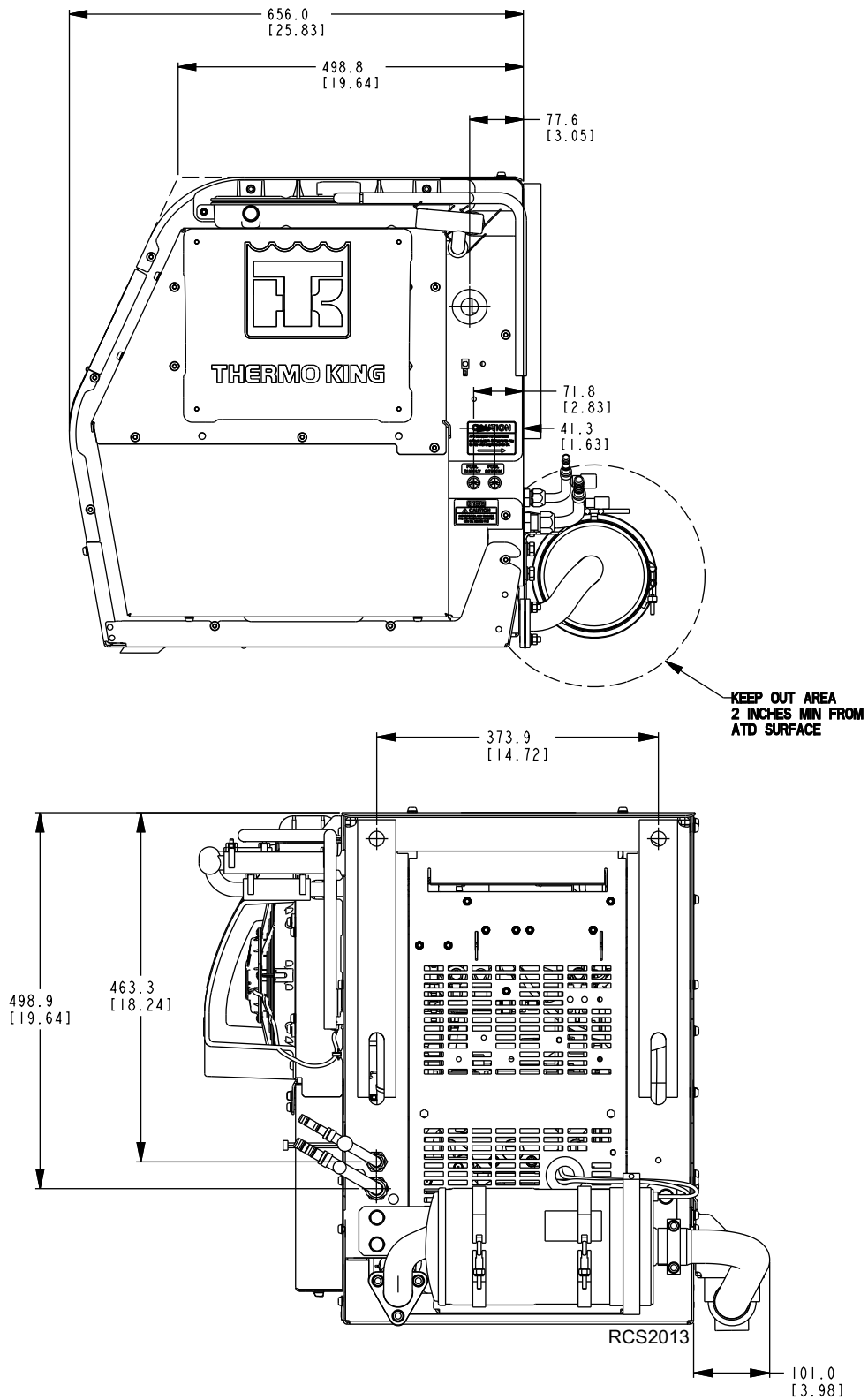
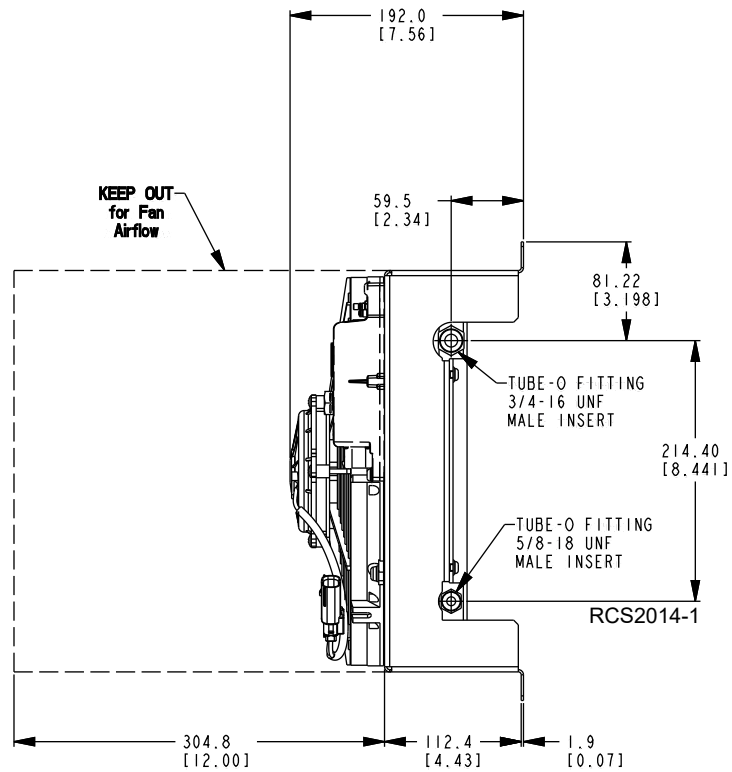
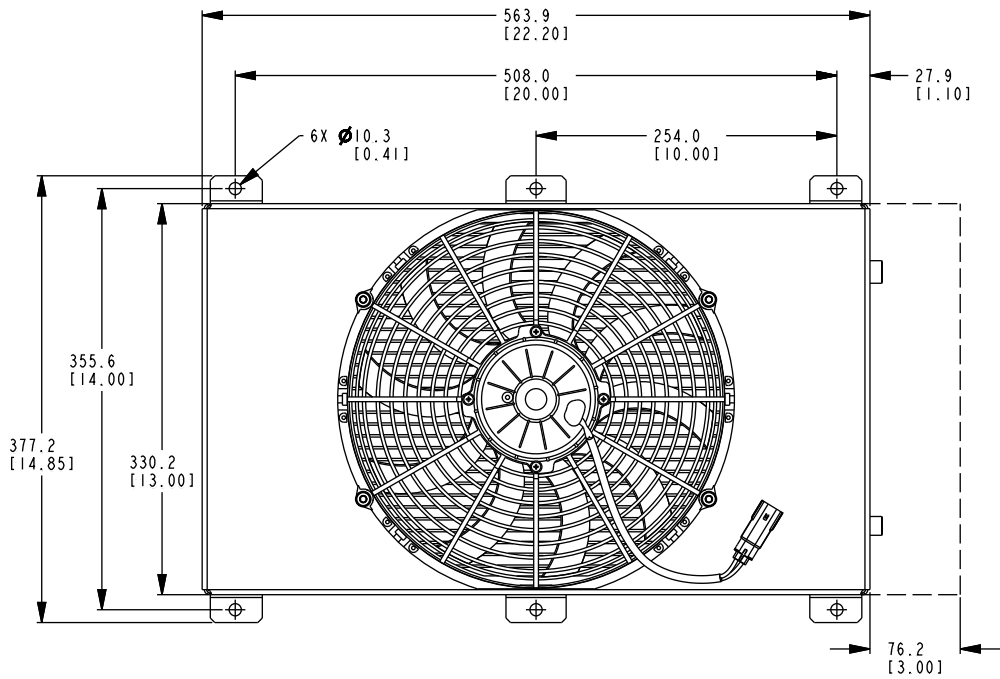

Figure 3. APU with ATD (Aftertreatment Device) Option Shown





Condenser Assembly



Evaporator/MAC Assembly (brackets as shipped)

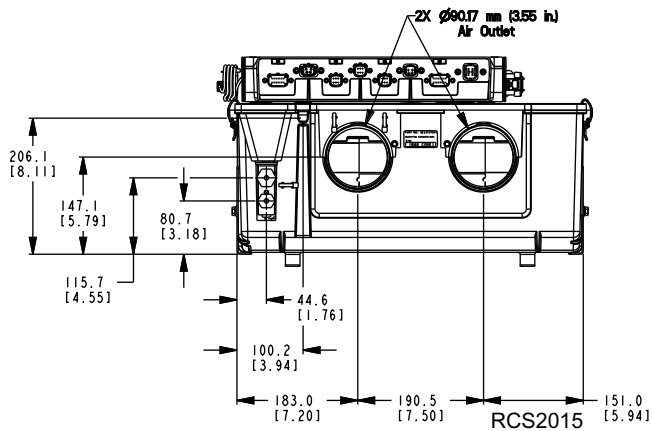
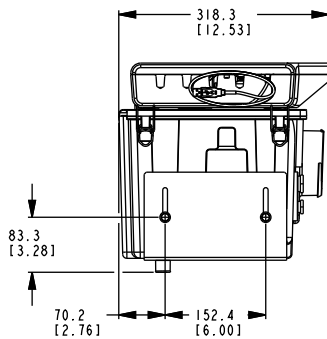
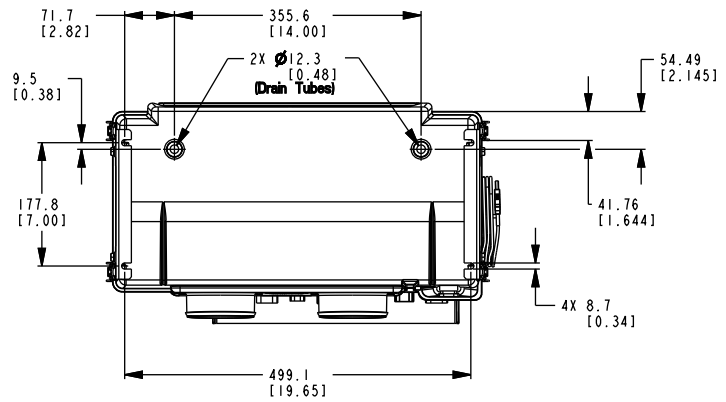
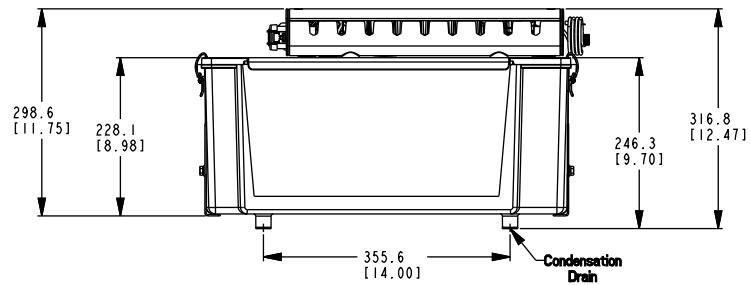
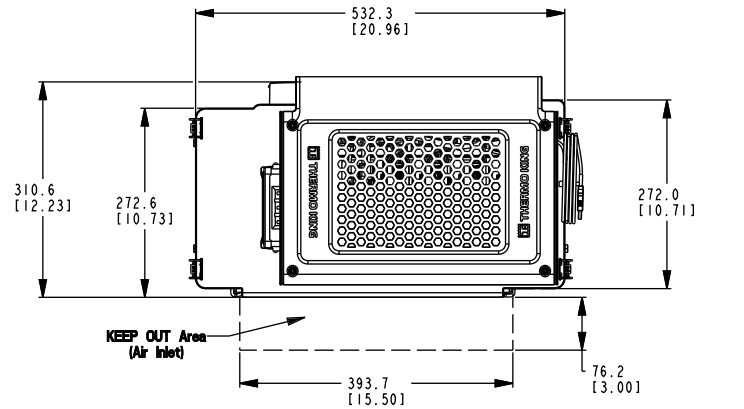



THERMO KING

TriPac 3 Component Dimensions

Evaporator/MAC Assembly (brackets as installed)

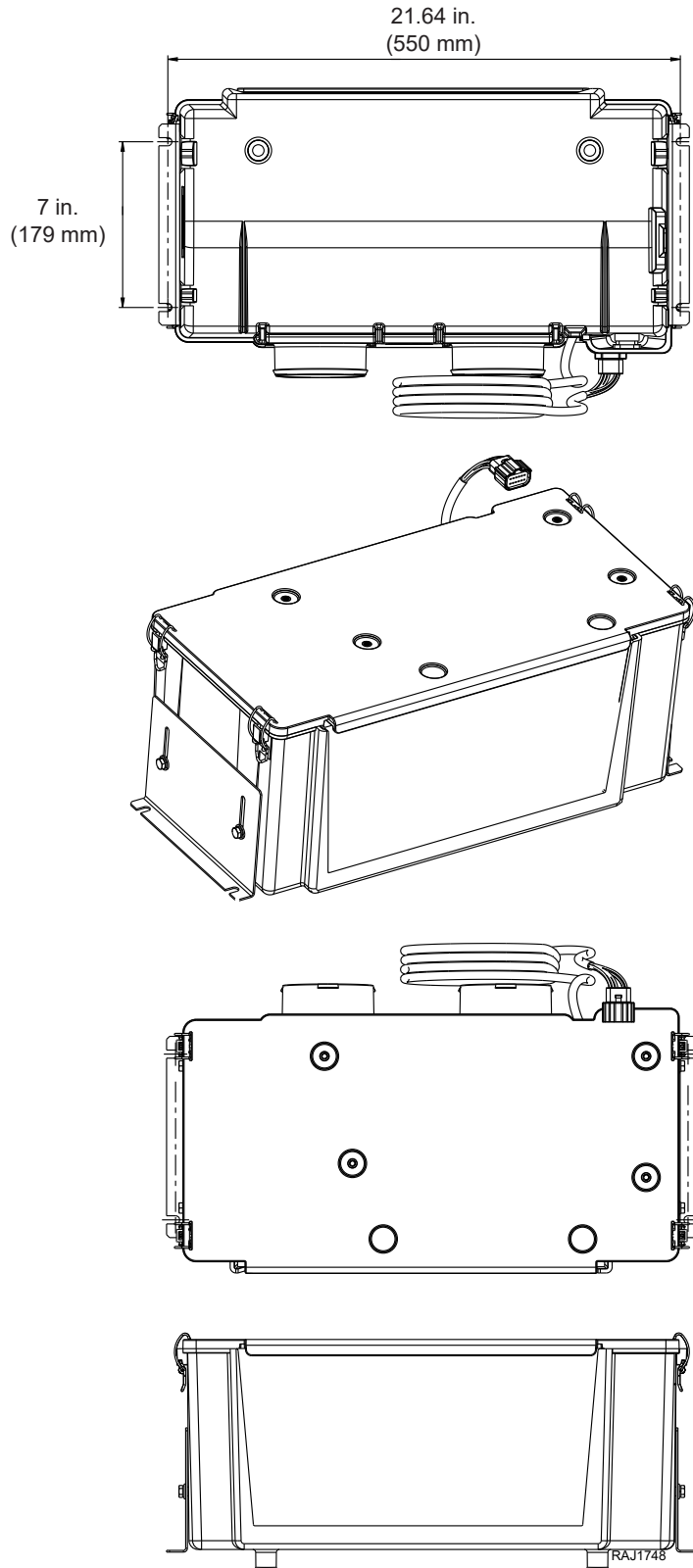

MAC Controller

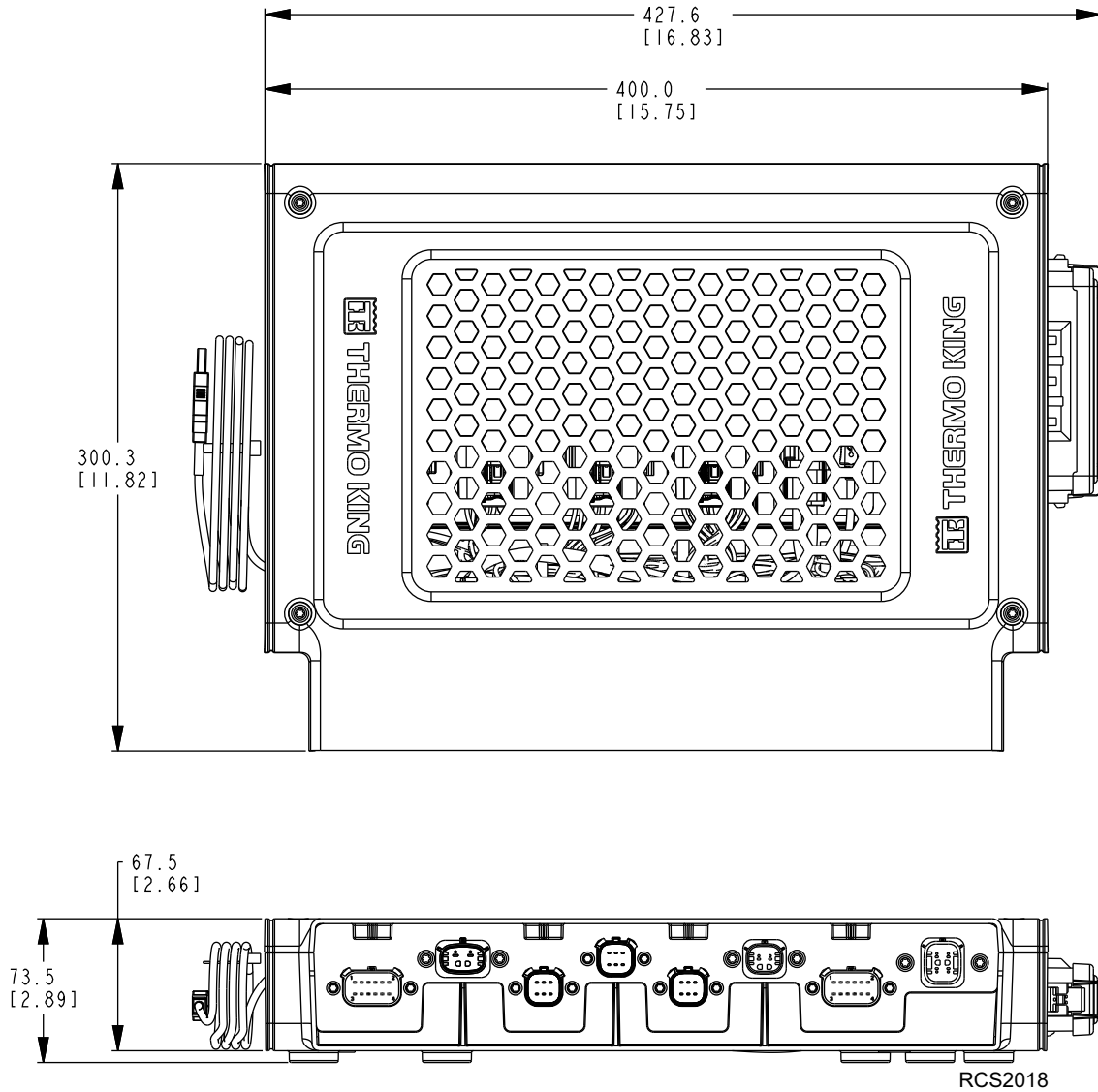

THERMO KING
TriPac 3 Component Dimensions

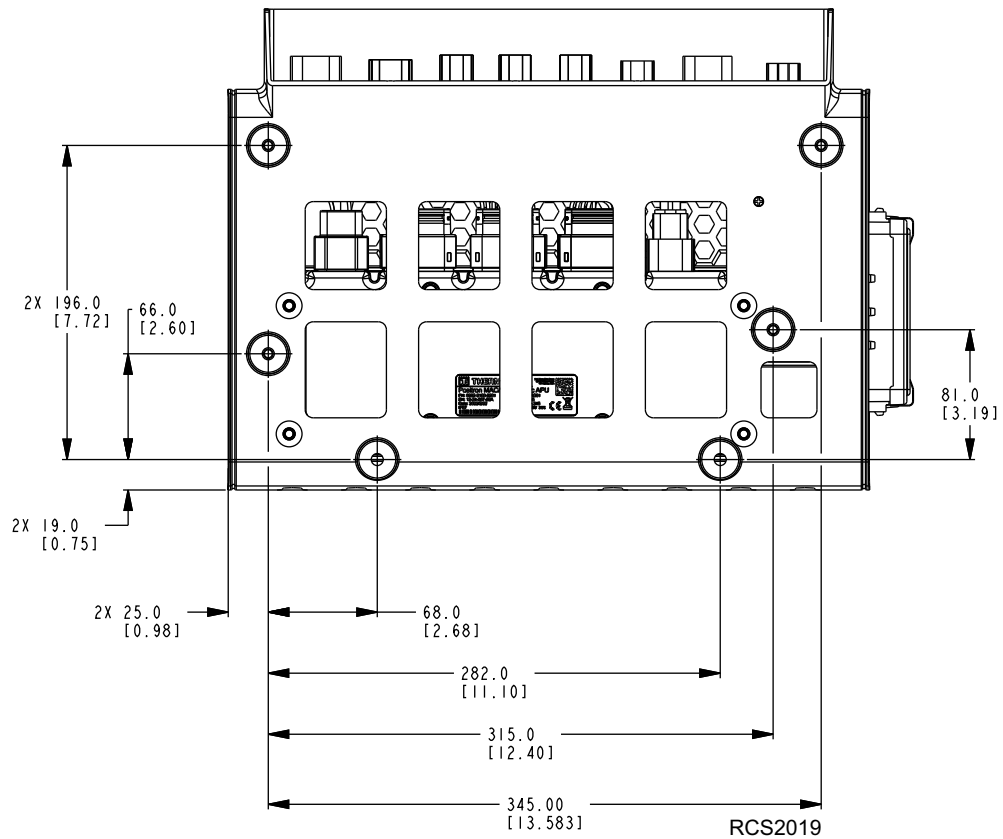
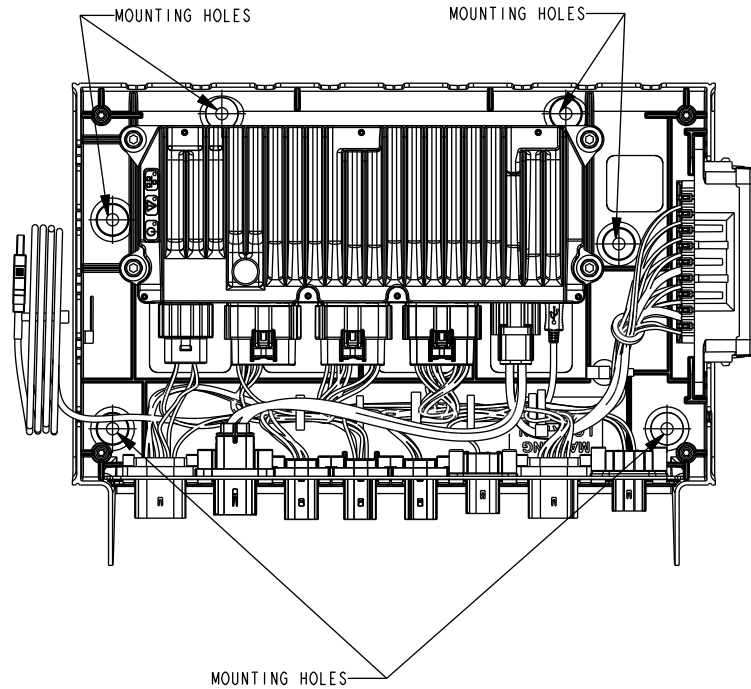

Standard Heater

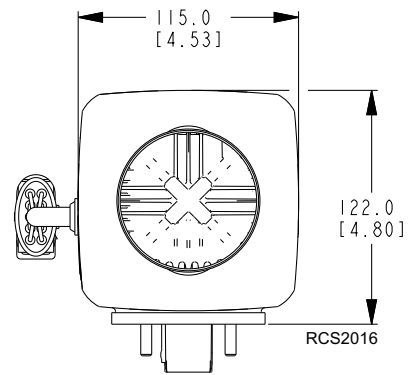
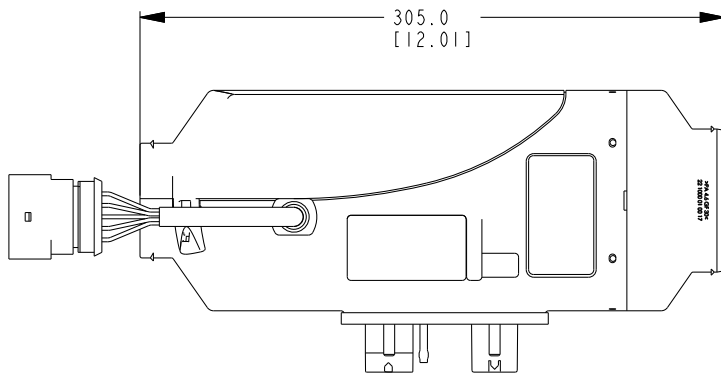

High Output Heater (Option)

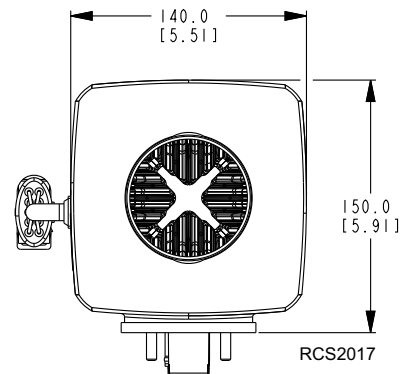
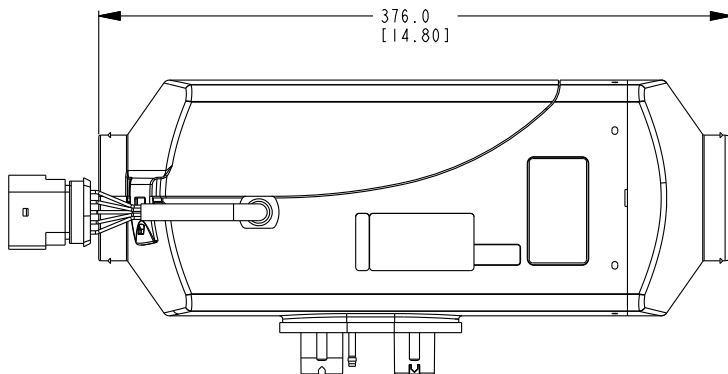

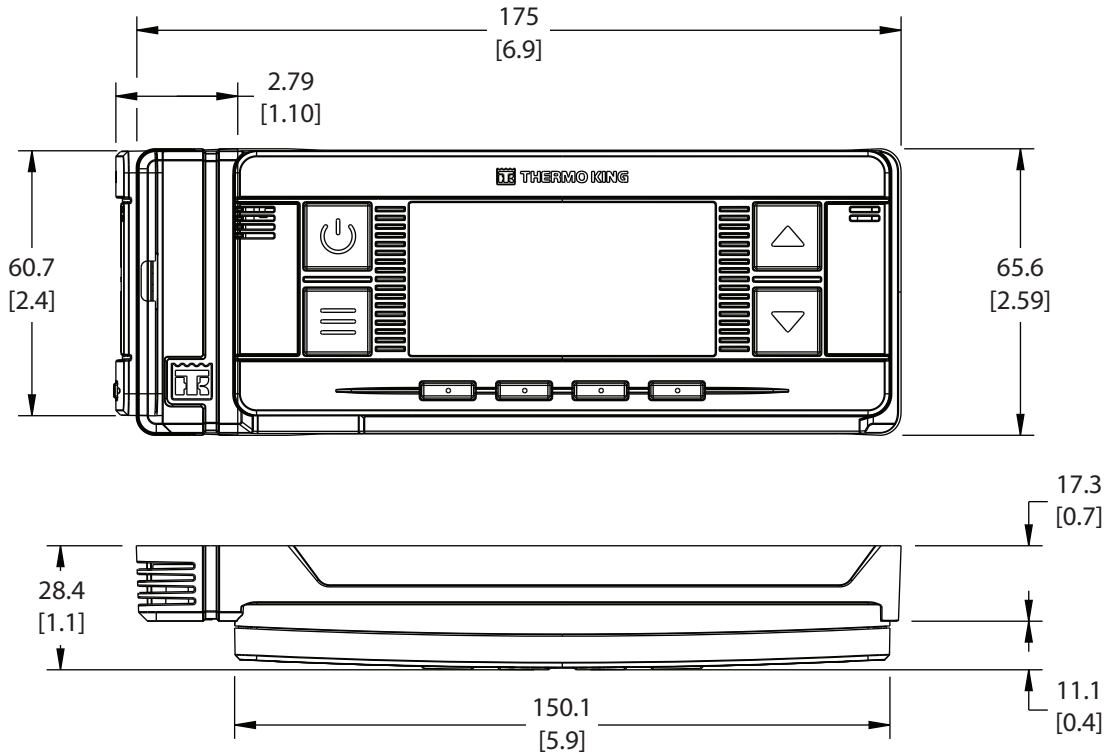
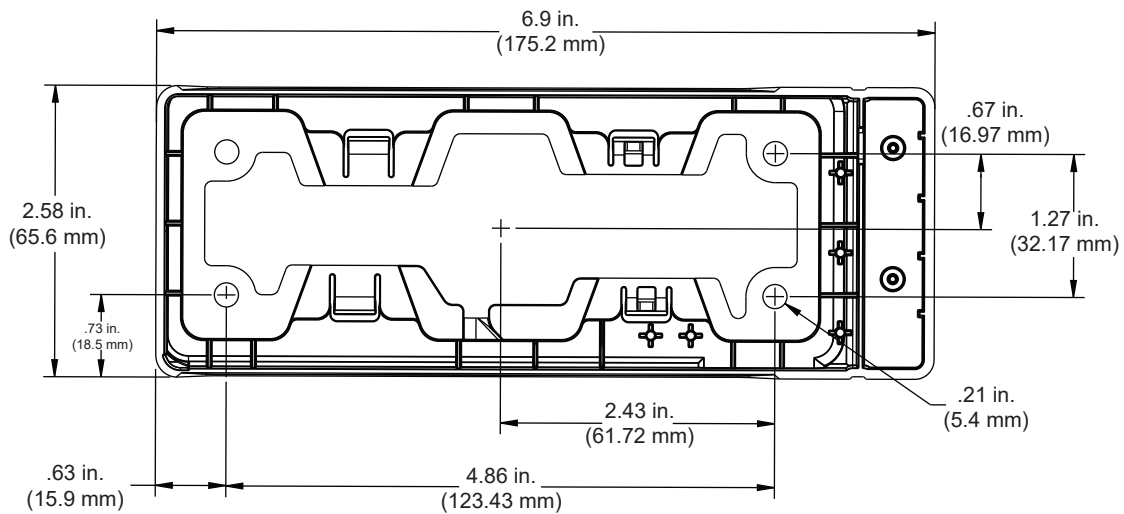
HMI
HMI

Mounting Plate / Bracket

RAJ1747

Required Tools and Additional Supplies

Note: While basic mechanics tools and refrigerant service equipment are a necessity, there are also special tools that are required when installing Thermo King TriPac Units. For a complete listing of special tools, See “Special Tool Requirements” Section 3 of the Thermo King TriPac Installation Standards Guide (TK 56498).

TOOLS	SUPPLIES (as required)
<ol style="list-style-type: none"> 1. Typical Mechanics Tools 2. Floor Jack or Motorcycle/ATV Lift 3. Drill Motor 4. Drill Bit Set 5. 7/8" dia. or 1" Step Reamer (for evaporator drain and controller holes) 6. Hole Saws <ul style="list-style-type: none"> • 1-1/4" dia. (for fuel tank pickup tube) • 2-1/2" dia. (for heater outlet louver) • 3" dia. (access hole for evaporator hoses and electrical wiring) • 4-1/4" dia. (mounting A/C louvers, routing A/C ducts through bulkheads and heater mounting hole) • 3-3/4" Hole Saw (for installing ESPAR discharge air vent and return air grille) • 3-1/4" Hole Saw (for routing ducts through compartment walls if required) 7. Reciprocating Saw (return air opening) 8. 1/2" Drive Torque Wrench 9. Level 10. Tape Measure 11. Utility Knife 12. Caulk Gun 13. Tubing Cutter (for cutting fuel pickup tubes) 14. Strobe Light/Tachometer (2040436) 15. Digital Meter (2040615) 16. Leak Detector (2040756) 17. Hose Fitting Tool (20401045) 18. Hose Cutting Tool (2040677) 19. Heater Fuel System Priming: <ul style="list-style-type: none"> • Heater priming harness 2041144 must be modified to work with the TriPac 3 Series of Espar AS2 D2L /AS2 D4L, AS3 D2L, AM3 D4L heaters. • Heater priming harness 2041144 and jumper harness 2043233 can be used together to prime the TriPac 3 Espar AS2 D2L /AS2 D4L, AS3 D2L, AM3 D4L heater fuel system. • Heater priming harness 2043232 can be used without jumpers or modifications to prime the TriPac 3 spar AS2 D2L /AS2 D4L, AS3 D2L, AM3 D4L heater fuel system. • The Air Heater EasyScan Diagnostic Tool 2043228 is capable of priming the TriPac 3 heater fuel system. See "Priming the Heater Fuel Pump" chapter in this manual. 20. Heater EasyScan Tool (2043228) 21. Shop Vacuum 	<ol style="list-style-type: none"> 1. 1/2" Brass Fittings (for coolant lines) <ul style="list-style-type: none"> • 45 degree elbow, MPT x FPT • 90 degree elbow, MPT x FPT • Tee, FPT x FPT x FPT • Hose Fitting, 1/2" NPT to 3/4" Hose • Closed Nipple, 1/2" NPT 2. Teflon Pipe Thread Tape (for coolant fittings) 3. Antifreeze, up to 2 gallons (must be the correct type to match original) 4. RTV Silicone 5. Sealing Putty (203-391) 6. PAG Refrigerant Oil (203-544) 7. Refrigerant 134A. 8. Return air wall louver approx. 6" x 10" (when needed) 9. Shrink Tubing 0.51" to 0.16" w/adhesive (for battery cable terminals) 10. Mounting Clamps #24 and #32 (to secure cables and hoses) 11. Band wraps (assorted sizes and lengths) 12. Upholstery Cleaner (approx. 2 cans) 13. Cardboard or blankets (to protect interior) 14. Fiberglass Repair Kit (only used for fiberglass and wood composite floors)

Typical Component Locations

Note: Proper installation of each component onto the vehicle is critical!. Refer to the Thermo King TriPac Installation Standards Guide (TK 56498) before beginning the installation. Adhering to the installation standards will help assure the components are installed correctly and the system operates as designed. It is the responsibility of the installer to follow these standards.

Figure 4. Typical TriPac 3 Component Locations Shown

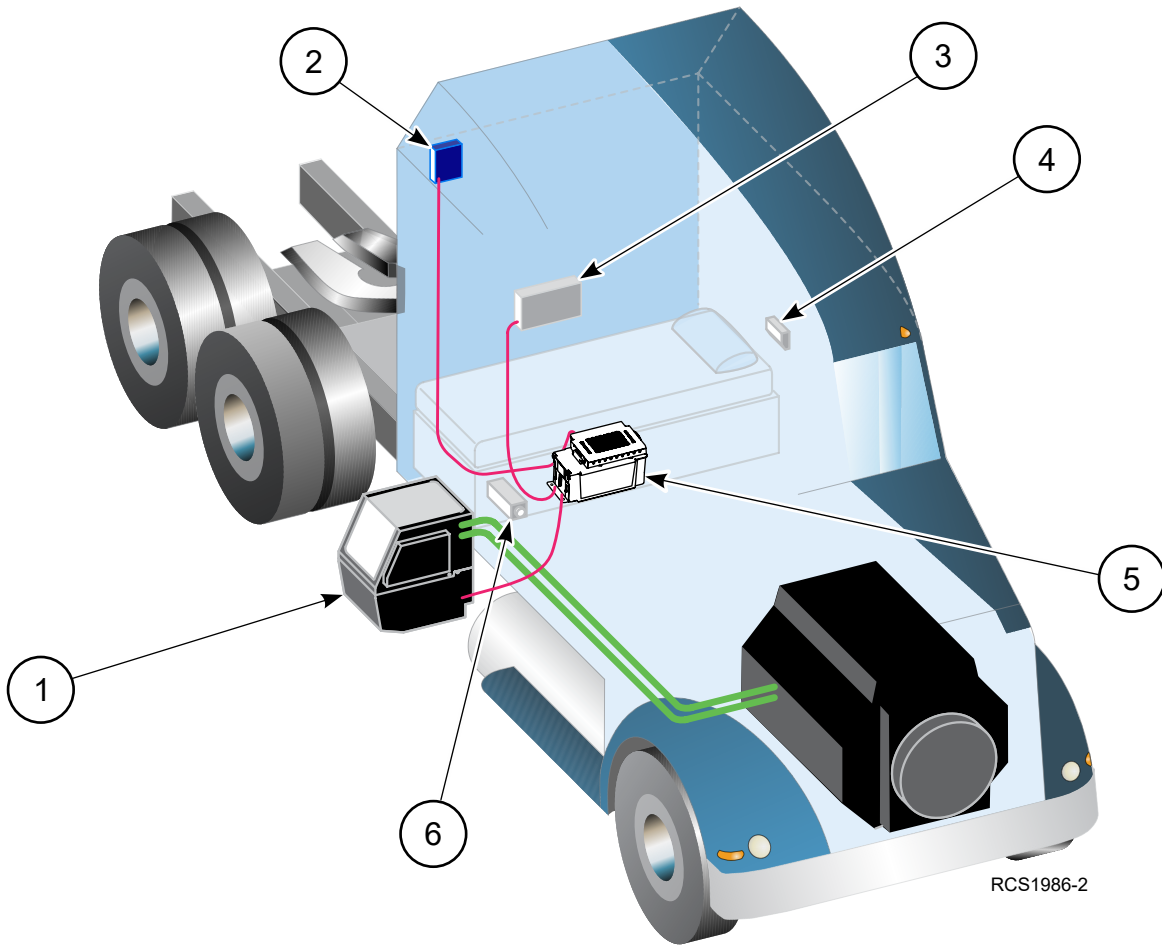

1.	APU is typically mounted on the passenger side frame rails of the truck.
2.	(Telematics Option) For maximum signal strength the telematics module should be mounted as high as possible on rear exterior of cab/ sleeper with an unobstructed line of sight towards the sky.
3.	A/C Condenser is typically mounted directly onto the rear exterior of the truck cab.
4.	HMI Controller is installed on wall inside the sleeper compartment.
5.	A/C Evaporator and MAC are typically installed together (or separately) under the bunk inside the sleeper compartment.
6.	Diesel fired heater is typically installed in the cargo/tool compartment with the outlet tube routed into the sleeper compartment.

TriPac 3 Components with Truck Coolant Integration

Figure 5. TriPac 3 Components with APU Coolant Hoses Tee'd Directly Into Truck's Heater Hoses

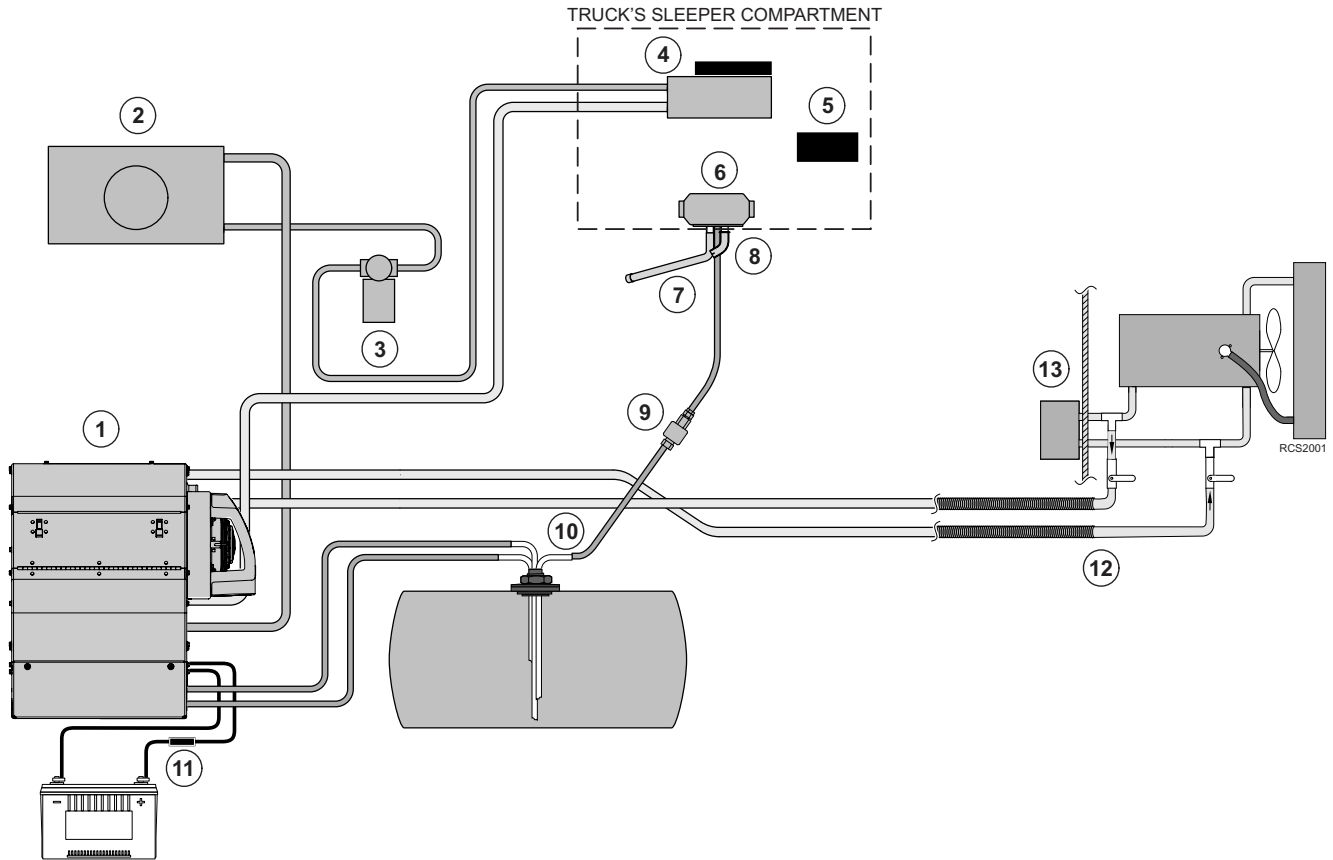

1.	TriPac 3 APU	8.	Heater Air Intake Tube
2.	A/C Condenser	9.	Heater Fuel Pump
3.	A/C Receiver Drier	10.	Heater and APU Diesel Fuel Pickup and Return Tubes
4.	A/C Evaporator / MAC Assembly	11.	Main Power Fuse
5.	HMI	12.	Coolant Supply and Return Hoses with Shutoff Valves
6.	Heater (Diesel Fired)	13.	Truck's Heater Core
7.	Heater Exhaust Tube		

TriPac 3 Components with Optional Closed Loop Cooling

Figure 6. TriPac 3 Components with Optional Closed Loop Cooling

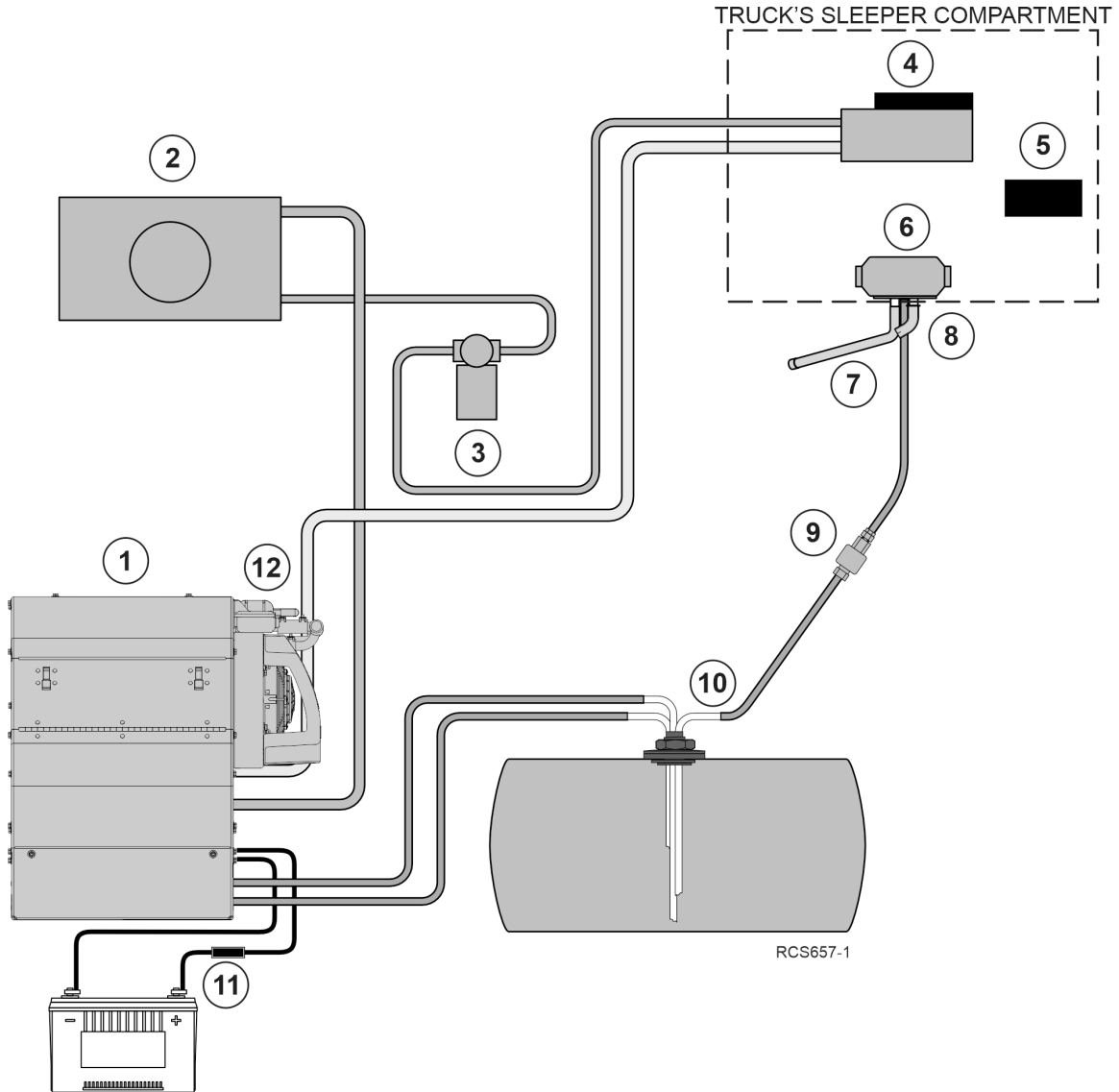

1.	APU	7.	Heater Exhaust Tube
2.	A/C Condenser	8.	Heater Air Intake Tube
3.	A/C Receiver Drier	9.	Heater Fuel Pump
4.	A/C Evaporator / MAC Assembly	10.	Heater and APU Diesel Fuel Pickup and Return Tubes
5.	HMI	11.	Main Power Fuse (connects to truck's batteries)
6.	Heater (Diesel Fired)	12.	Coolant Expansion Tank

APU Installation

Standard Installation Method – Mounting Claws

Important: See “TriPac Evolution Installation Standards” in Section 5 of the Thermo King TriPac Installation Standards Guide (TK 56498). **THESE STANDARDS MUST BE FOLLOWED!**

Special Tools Required
Modified Floor Jack or Motorcycle/ATV Lift
1/2" Drive Torque Wrench

1. Remove top cover of TriPac APU to access and remove mounting hardware securing APU to shipping crate.
2. It is recommended that a modified floor jack or motorcycle/ATV lift be used to install the APU. Protection such as cardboard, shop rags, etc. should be used under the APU to prevent damage during installation.
3. Raise the APU into position. From outside the APU, insert the 3/4 in. mounting bolts and washers through mounting claws and spacer blocks (slots go down) and into APU’s frame mounting holes.
4. From inside the APU, loosely install washers, nut retainers and locking nuts in that order. **DO NOT OIL THE BOLT THREADS!**

Important: The following steps are critical and must be followed to ensure the safe installation of the APU to the tractor’s frame.

5. With APU still supported by a lift:
 - a. Push APU and spacer blocks up tight to tractor frame.
 - b. Adjust height of the APU so top and bottom mounting claws and bolts are positioned flat on frame. Review (Detail A).
 - c. Lightly tighten mounting hardware only enough to remove excess play.
6. Using a torque wrench, torque mounting bolts in four step increments starting with top bolts, then bottom bolts.
STEP 1: Torque top then bottom mounting bolts to 25 ft-lb. (33.9 N•m).

Important: STOP and verify all mounting claws and bolts remained flat on frame (Detail A). If they are not, loosen bolts, adjust as necessary and retighten again to 25 ft-lb. (33.9 N•m).

STEP 2: After first step is successfully completed, torque top then bottom bolts to 50 ft-lb. (67.8 N•m).

STEP 3: Next, torque top and then bottom bolts to 100 ft-lb. (135.6 N•m).

STEP 4: Finally, recheck all bolts to confirm they are at 100 ft-lb. (135.6 N•m)

Important: DO NOT OVER-TORQUE MOUNTING BOLTS!

7. Remove the support lift and visually inspect installation for the following:
 - Mounting claws and bolts are **correctly** installed. They should be square and flat on the frame (**Detail A**).
 - If any mounting claws and bolts are **improperly** installed on the frame (i/e. they resemble Details B & C) - adjust as necessary.
 - Damaged, deformed or cracked components during installation - **must be replaced immediately**.

Figure 7. Standard Installation Method with Mounting Claws Shown

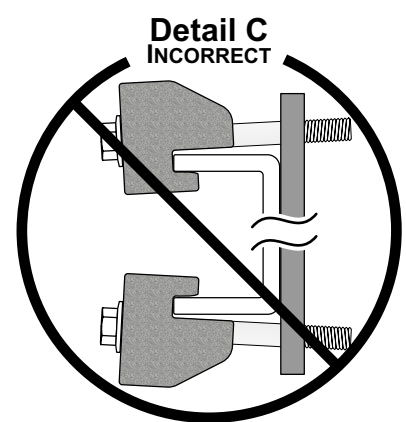
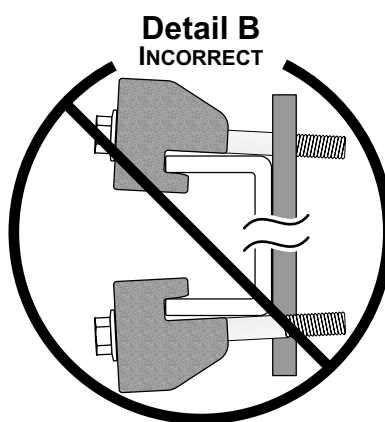
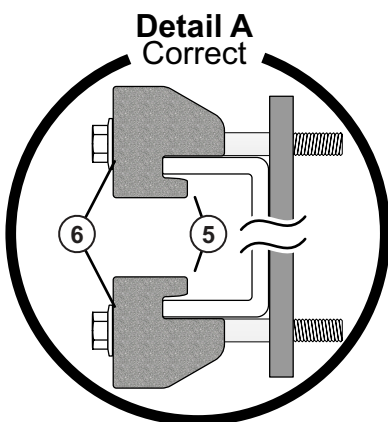
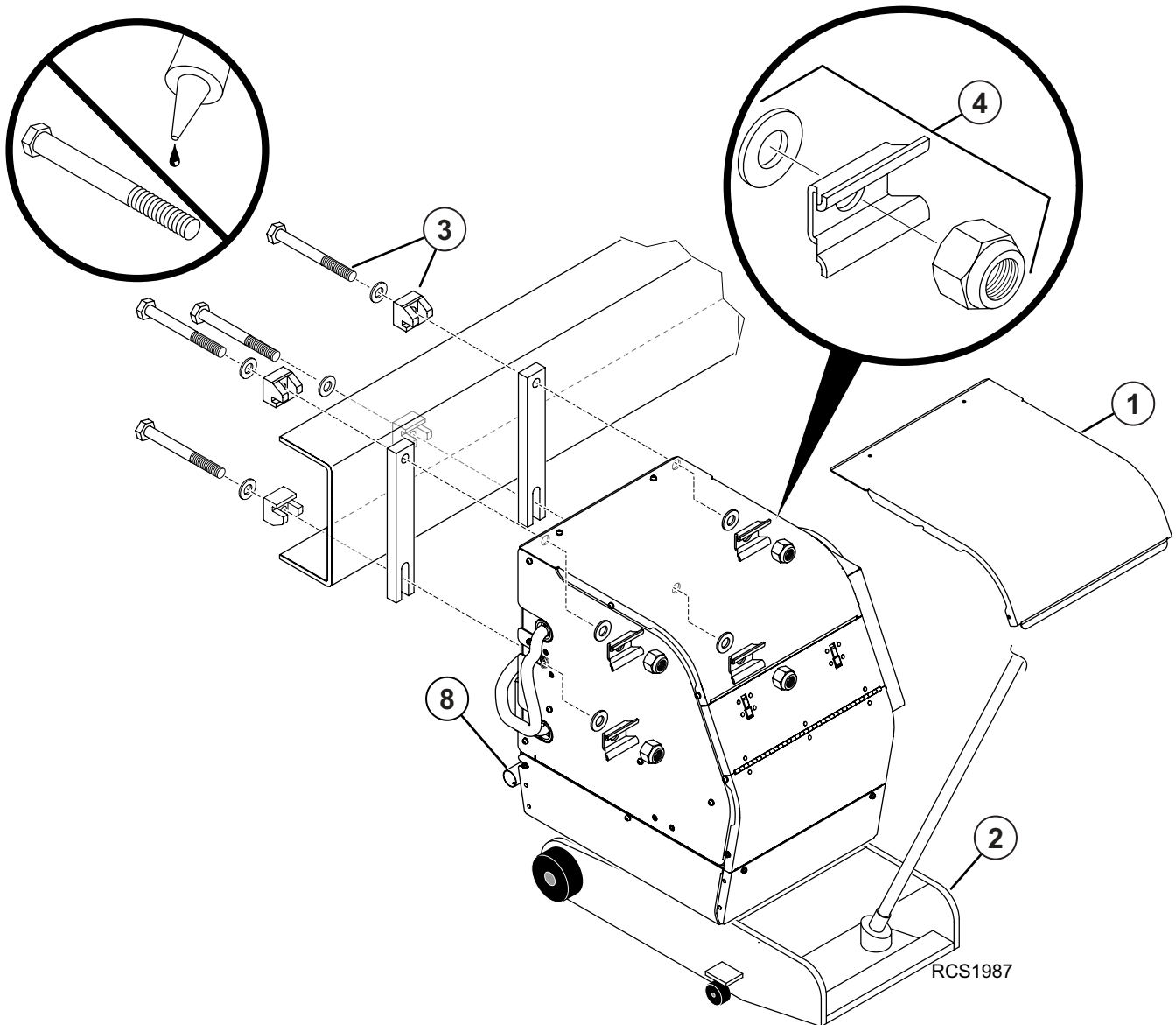

Exhaust Pipe Installation

Important: See “APU Exhaust Tailpipe Installation Standards” in Section 5 of the Thermo King TriPac Installation Standards Guide (TK 56498). **THESE STANDARDS MUST BE FOLLOWED!**

Important: When a diesel powered APU is installed under a sleeper, behind fairings, skirting, etc., the exhaust outlet must be routed to an open area to prevent exhaust fumes from entering the passenger compartment which could result in carbon monoxide poisoning or death by asphyxiation. Optional exhaust pipe extensions are available for this purpose. Contact your nearest Thermo King Dealer.

Standard Short Exhaust Tailpipe

A short exhaust tailpipe is provided standard with each APU.

1. Install short exhaust tailpipe (outlet facing down) onto end of muffler and secure with clamp.

Optional Exhaust Extension

The optional exhaust extension is used along with the standard short tailpipe.

1. Install mounting bracket onto side of APU.
2. Install extension pipe and clamp onto end of muffler.
3. Install short exhaust tailpipe (supplied with APU) and clamp.
4. Face tailpipe outlet down or towards rear of tractor.
5. Tighten all clamps securely.

Figure 8. Standard Short Exhaust Tailpipe and Optional Exhaust Extension Shown

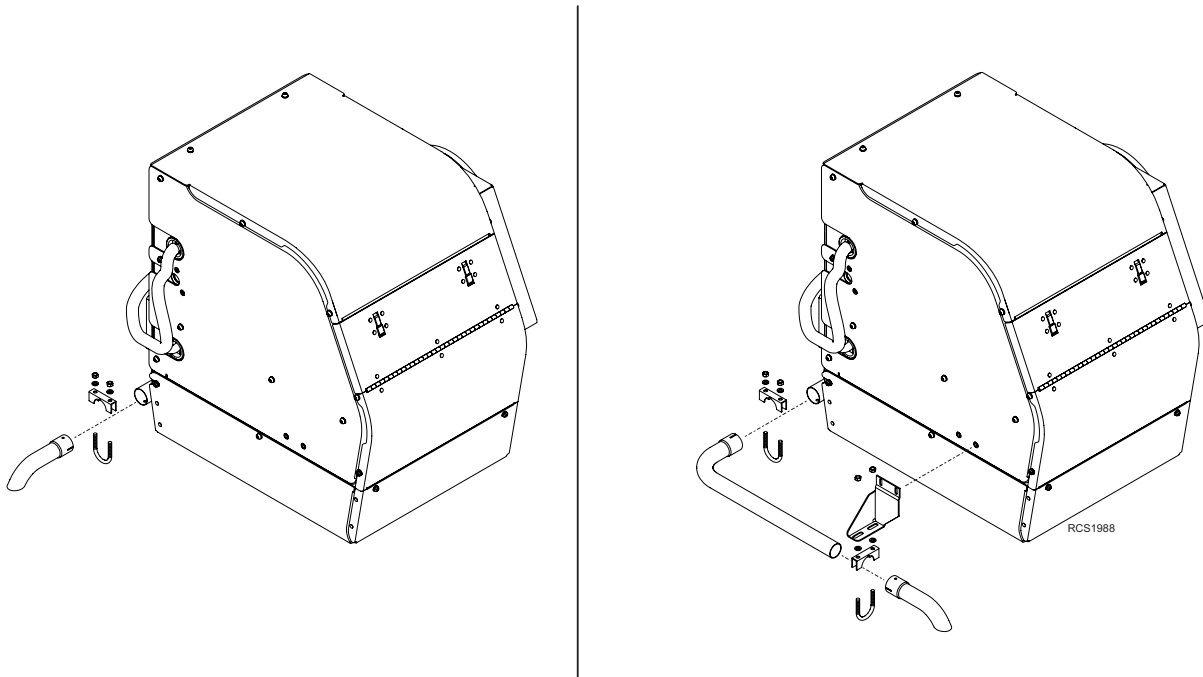

A/C Condenser Installation

Important: See “Condenser Installation Standards” in Section 5 of the Thermo King TriPac Installation Standards Guide (TK 56498). **THESE STANDARDS MUST BE FOLLOWED!**

Locate an area on the exterior of the sleeper to install the condenser that does not interfere with the operation of existing truck components. If possible mount the condenser below the bunk level. This allows easier access to four 3/8” bolts with large fender washers inside without disturbing interior panels.

Alternative Mounting Method — secure condenser to cab with 3/8–16 threaded rivet nuts.

Important: Before drilling any holes, check for interference with internal wires, supports or interior panels. Avoid drilling into the truck’s interior support members as this could void the tractor’s OEM warranty.

Special Tools Required
Tape Measure
Level
Drill Motor
3/8” Drill Bit
Caulk Gun and RTV Silicone Sealant

The condenser housing and coil assembly can be also installed with the hose fittings facing towards the roadside (**DETAIL A**) if needed. When doing so, the actual condenser coil must be removed from the housing and rotated so the #8 fitting is on top by:

- a. Rotating the complete condenser housing and coil assembly so the hose fittings are facing towards the roadside.
 - b. Removing the condenser coil from the housing, and rotating it so the #8 fitting is positioned at the top, then install it back into the condenser housing and tighten the hardware securely.
1. Measure and mark the exterior center line of the sleeper.
 2. Center and level the condenser onto the sleeper with the #8 fitting located on top. Mark the mounting holes; typically one in each corner. Drill four 3/8” mounting holes.
 3. Apply a bead of RTV silicone along the entire condenser mounting flanges and around each of the four mounting holes (or threaded rivet nuts).
 4. Install the condenser with 3/8” stainless mounting bolts and large fender washers from the inside, and 3/8” washers and locking nuts on the outside. Tighten hardware securely.

Figure 9. Typical Condenser Installation Shown

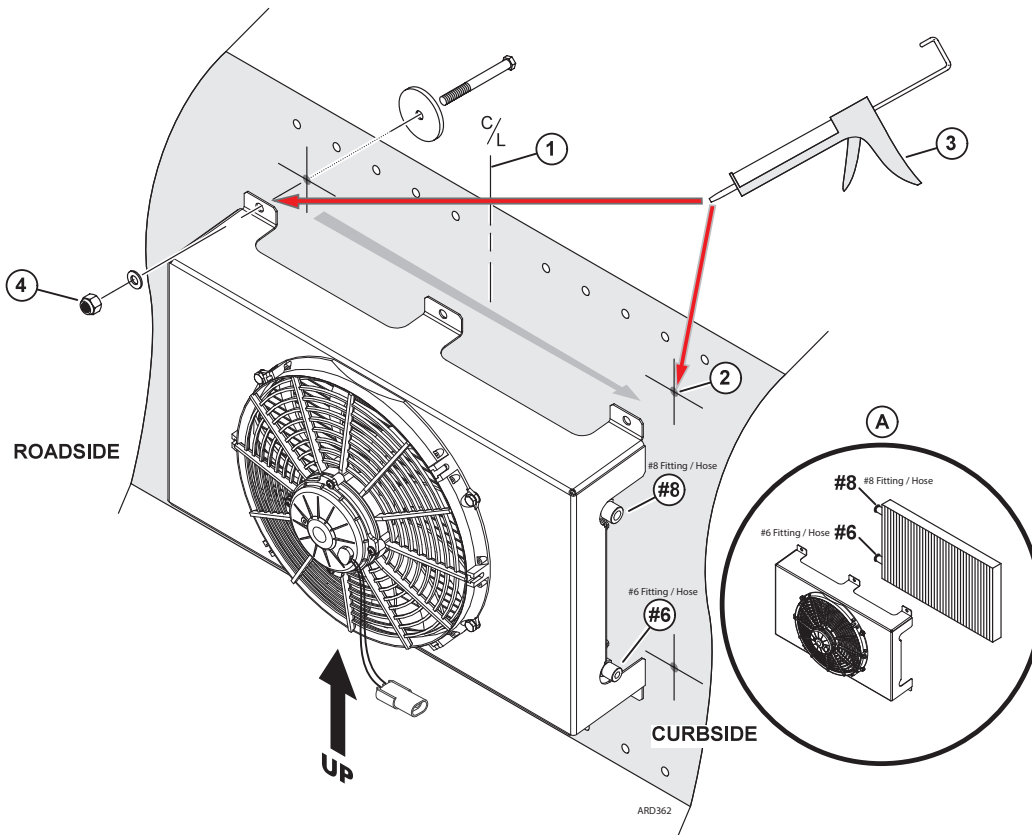

A/C Receiver Drier Installation

Important: See “Receiver Drier Installation Standards” in Section 5 of the Thermo King TriPac Installation Standards Guide (TK 56498). **THESE STANDARDS MUST BE FOLLOWED!**

Special Tools Required
Drill Motor
3/8" Drill Bit
Level

Note: It is recommended to mount the receiver drier directly onto the sleeper to reduce hose flexing.

Locate an area on the exterior of the tractor to install the receiver drier.

Typical Mounting Locations:

- a. Side-by-side Mount (**DETAIL A**)
- b. Mid-height Mount (**DETAIL B**).
- c. High Mount (**DETAIL C**).

1. Position and level the receiver drier bracket and mark each of the two mounting holes. Drill two 3/8" holes.
2. Attach two large hose clamps to the bracket with 3/8" stainless mounting bolts, washers and locking nuts (installer supplied) and tighten securely.
3. With the switch facing out, install the receiver drier onto the bracket and tighten the hose clamps securely.

Figure 10. Receiver Drier Installation Shown

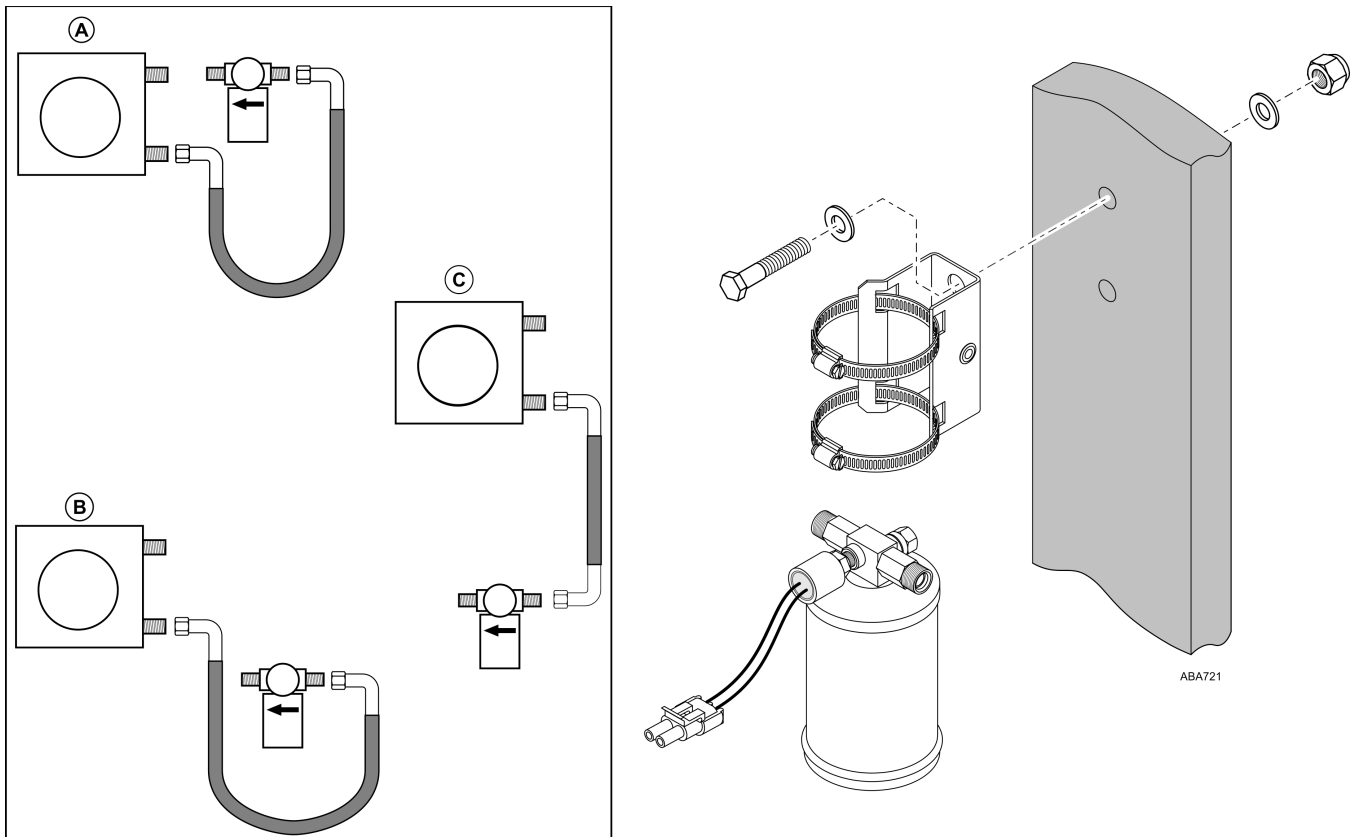

A/C Evaporator / MAC Installation

Preferred Location – Flush with Front Bulkhead

Important: See “Evaporator Installation Standards” in Section 5 of the Thermo King TriPac Installation Standards Guide (TK 56498). **THESE STANDARDS MUST BE FOLLOWED!**

A template is supplied to represent the amount of area needed to accommodate the evaporator. It also provides locations for the two 7/8” drain holes and the 3” access hole.

The MAC (Main Application Controller) is factory installed on top of the evaporator. It can also be removed from the evaporator and mounted remotely under the bunk if needed.

IMPORTANT ACCESS HOLE INFORMATION:

- The location of the 3” access hole will be determined by your particular sleeper construction, including OEM internal floor supports, electrical wiring, etc. It should be located directly behind the evaporator’s A/C fittings to allow the refrigerant hoses with 90 degree fittings to be attached and routed down through the floor easily.
- Floors made from fiberglass covered wood construction require the edges of the 3” access hole be completely sealed with fiberglass and epoxy resin.
- Before drilling any holes, check for interference with internal wires, supports or interior panels. Avoid drilling into the truck’s support members.

Special Tools Required
Drill Motor
1/4” Drill Bit
7/8” Step Reamer
3” dia. Hole Saw
Reciprocating Saw
Caulk Gun and RTV Silicone Sealant
Sealing Putty (203-391)
Fiberglass Cloth and Resin Kit (if required)

1. Position the template flush with the bulkhead, mark the location of the 7/8” evaporator drain holes and the 3” access hole. Remove the template.
 - a. Drill 1/4” pilot hole for the drain holes followed by a 7/8” step reamer.
 - b. Drill 3” access hole.
2. Cut and install a piece of split loom (or similar) around the inside edge of the 3” access hole to provide protection for the hoses and wiring.
3. Reposition the evaporator mounting brackets attached to sides of the evaporator.
4. Set the evaporator in place and determine where the return air opening needs to be located on the bulkhead.
5. Mark the return air opening (minimum opening size 14" x 7"). Remove the evaporator and cut the opening. Install the evaporator to the floor with TEK screws.
6. Install a return air grille (installer supplied).
7. From underneath the sleeper:
 - a. Attach the two water valves (kazoos) onto the evaporator drain tubes and secure with supplied hose clamps
 - b. Seal around the drain tube access holes with sealing putty or silicone sealant.
 - c. Apply silicone sealant around the four evaporator mounting screws.
 - d. Seal any unused holes, cracks, or visible air gaps that might be found.

Figure 11. Preferred Location – Flush with Bulkhead Shown

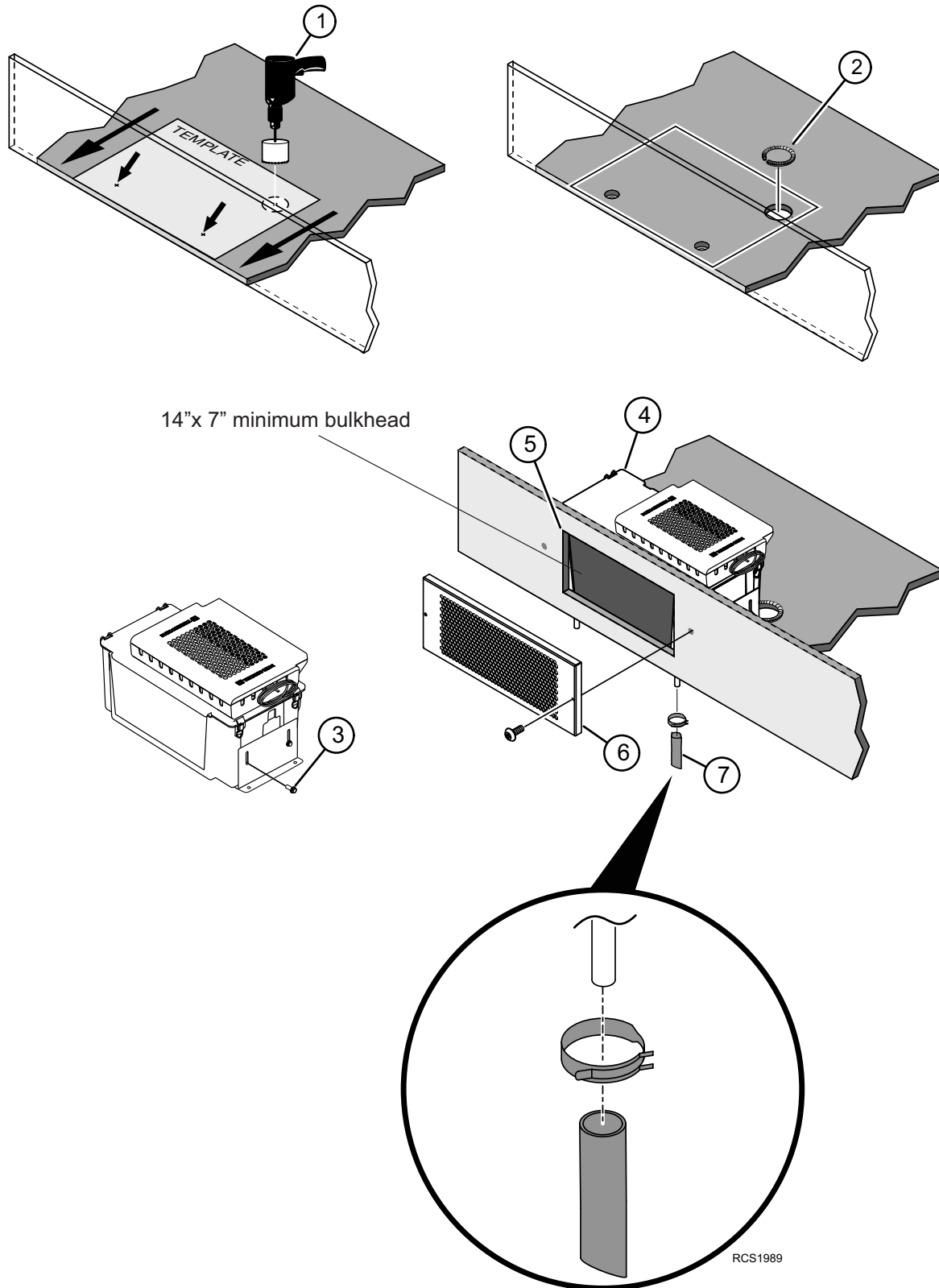



Alternative Location – Centered Under Bunk

Important: See “Evaporator Installation Standards” in Section 5 of the Thermo King TriPac Installation Standards Guide (TK 56498). **THESE STANDARDS MUST BE FOLLOWED!**

A template is supplied to represent the amount of area needed to accommodate the evaporator. It also provides locations for the two 7/8” drain holes and the 3” access hole.

The MAC (Main Application Controller) can be removed from the evaporator and mounted remotely under the bunk if needed.

IMPORTANT ACCESS HOLE INFORMATION:

- The location of the 3” access hole will be determined by your particular sleeper construction, including OEM internal floor supports, electrical wiring, etc. It should be located directly behind the evaporator’s A/C fittings to allow the refrigerant hoses with 90 degree fittings to be attached and routed down through the floor easily.
- Floors made from fiberglass covered wood construction require the edges of the 3” access hole be completely sealed with fiberglass and epoxy resin.
- Before drilling any holes, check for interference with internal wires, supports or interior panels. Avoid drilling into the truck’s support members.

Special Tools Required
Drill Motor
1/4” Drill Bit
7/8” Step Reamer
3” dia. Hole Saw
Reciprocating Saw
Caulk Gun and RTV Silicone Sealant
Sealing Putty (203-391)
Fiberglass Cloth and Resin Kit (if required)

1. Position the template flush with the bulkhead, mark the location of the 7/8” evaporator drain holes and the 3” access hole. Remove the template.
 - a. Drill 1/4” pilot hole for the drain holes followed by a 7/8” step reamer.
 - b. Drill 3” access hole.
2. Cut and install a piece of split loom (or similar) around the inside edge of the 3” access hole to provide protection for the hoses and wiring.
3. Reposition the evaporator mounting brackets attached to the sides of the evaporator.
4. Install the evaporator to the floor with TEK screws.
5. Mark a location for a return air opening (minimum opening size 14" x 7") and cut the opening. Install a return air grille (installer supplied).
6. From underneath the sleeper:
 - a. Attach the two water valves (kazoos) onto the evaporator drain tubes and secure with supplied hose clamps
 - b. Seal around the drain tube access holes with sealing putty or silicone sealant.
 - c. Apply silicone sealant around the four evaporator mounting screws.
 - d. Seal any unused holes, cracks, or visible air gaps that might be found in the floor of the vehicle.

Figure 12. Alternate Location – Centered Under Bunk Shown

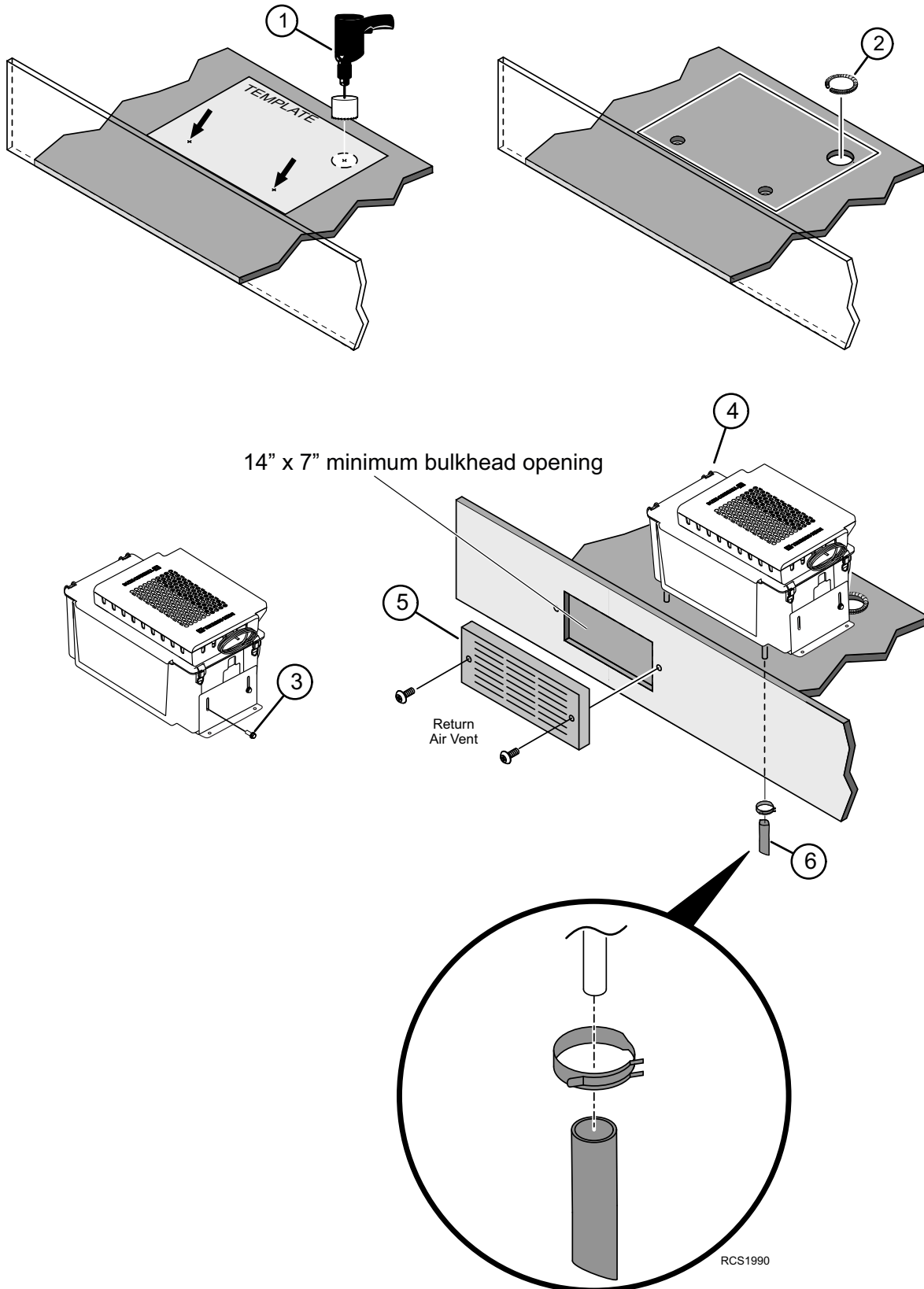

MAC Remote Installation

The MAC can be removed from top of evaporator and installed as a standalone component if necessary. Allow a minimum of 2.00 in. (50.8 mm) around all four sides of the MAC for air flow.

Figure 13. Provide for air flow around MAC

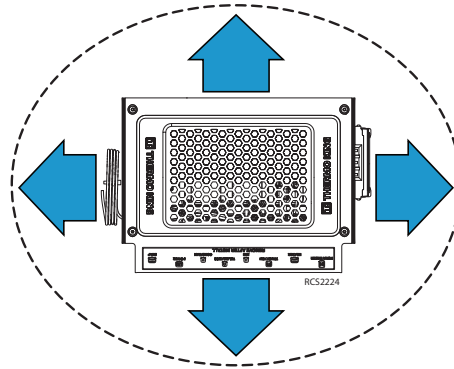

1. Remove the four screws securing cover, then remove the four screws securing the MAC to evaporator.
2. Install MAC in location chosen, secure with (installer supplied) fasteners and reinstall cover. Floor mount shown.
3. The MAC can also be installed in the vertical (as shown) or horizontal position (not shown).

Note: DO NOT overtighten the screws or damage to the MAC will result.

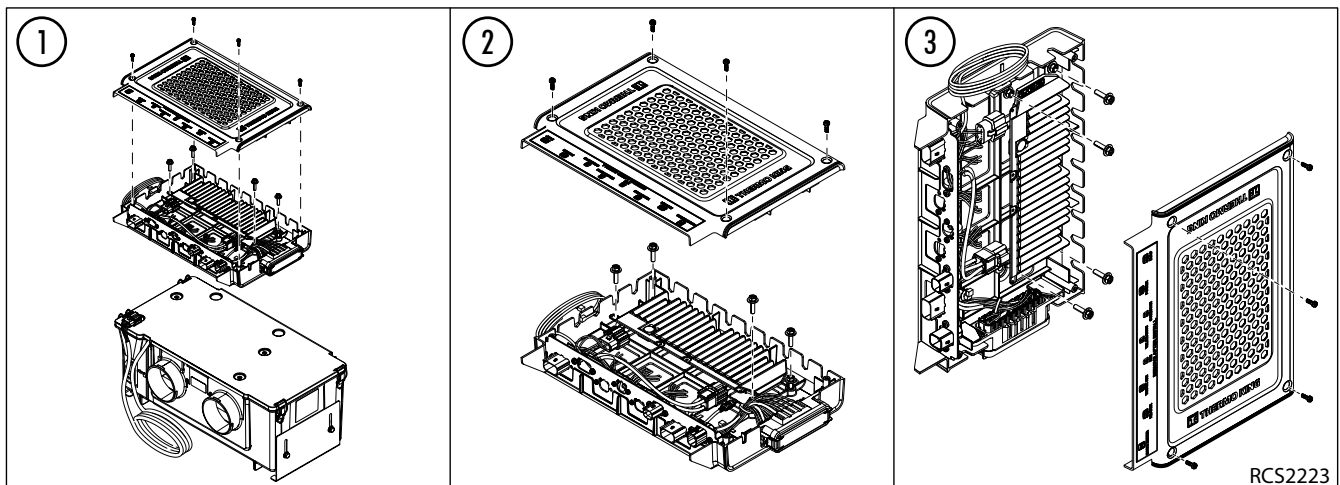

D2/D4 Heater Installation

Heater Location

Important: See “Heater Installation Standards” in Section 7 of the Thermo King TriPac Installation Standards Guide (TK 56498). **THESE STANDARDS MUST BE FOLLOWED!** Correct installation of this heater is necessary to ensure safe and proper operation. **BEFORE** installing the heater, thoroughly read and understand “Heater Safety Precautions” section in this manual along with the heater manufacturer’s manuals included with the heater.

The location for mounting the heater will vary depending on the type of tractor. Typically the heater is mounted inside the sleeper, under the bunk in a storage compartment. However, the heater may be mounted anywhere inside the tractor provided you adhere to the following conditions:

- Install heater so it will maintain a minimum distance of 2.00 inches (50.8 mm) from any heat sensitive or flammable material.
- Combustion air intake, exhaust and fuel inlet must be located outside the tractor.
- Install exhaust hose so it will maintain a minimum distance of 2.00 inches (50.8 mm) from any heat sensitive or flammable material.
- Heater must be mounted on flat horizontal surface providing an air tight seal between heater and tractor.
- All floor matting, carpet, insulation, etc. must be removed to allow the heater to be mounted directly to the bare floor.
- Heater harness may be repositioned to either side of the heater.
- Floors made of fiberglass covered wood construction require the edges of the access hole be sealed with fiberglass and epoxy resin.

Drilling Hole In Floor

Special Tools Required
Drill Motor
Utility Knife
Center Punch
4-1/4" dia. Hole Saw
Fiberglass Cloth and Resin Kit (if required)

1. Position the heater’s metal mounting plate onto the floor mat
2. Use a utility knife to cut the floor mat around the outside edges of the plate. Remove floor mat to access the bare floor.
3. With the mounting plate in position, center punch the four outer holes. Remove the mounting plate and mark an “X” connecting the four center punched outer holes.
4. Center punch the center of the “X” and drill a 4-1/4” hole with a hole saw.

Figure 14. Drilling Hole In Floor Shown

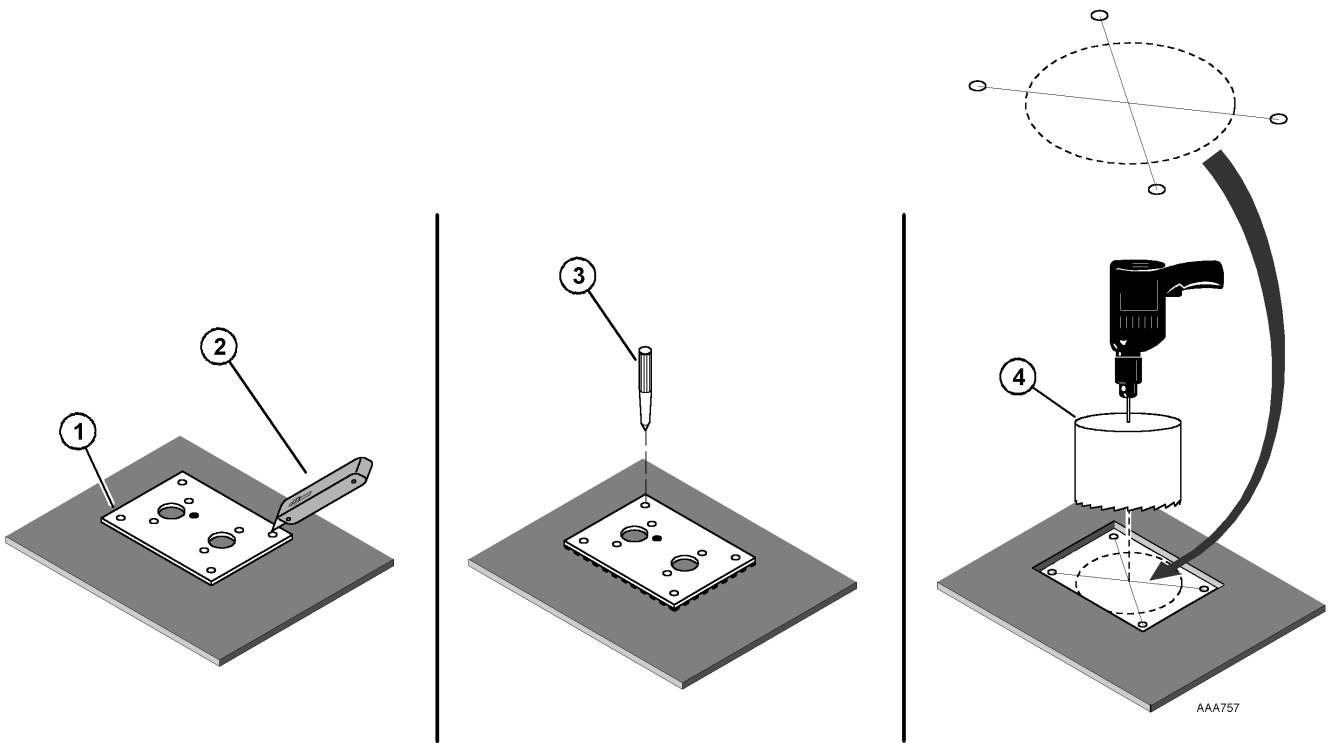

Heater Subassembly and Installation

Turn the heater upside down and attach the following components:

1. Snap the air outlet hood onto the end of the heater.
2. Place the mounting plate onto the heater studs. Mounting hardware will be installed later.
3. Attach the short rubber hose and clamps onto the fuel inlet connection located at the base of the heater.
4. Insert the plastic fuel line all the way into the rubber hose until it bottoms out to prevent air gaps. Tighten both hose clamps securely.
5. Attach the exhaust hose and metal clamp onto the fitting located under the OUTLET end of the heater. Turn metal clamp to the center and tighten securely.
6. Insert the plastic air intake tube through the beveled opening of the small plastic mounting plate. Install the plastic plate and tube onto studs located under the INLET end of the heater.
7. Install lock washers and nuts onto each of the mounting studs and tighten hardware securely
8. Install gasket to mounting plate.
9. The heater has two service data nameplates. Remove one and reinstall it onto the top of the heater so that it is visible when the heater is installed.
10. Position the heater over the access hole with intake and exhaust hose and fuel line exiting the tractor. Attach the heater to the floor with TEK screws and tighten securely.

Note: Tighten TEK screws sufficiently to ensure a positive seal between mounting plate and mounting surface. Do not over tighten!

Figure 15. Heater Subassembly Shown

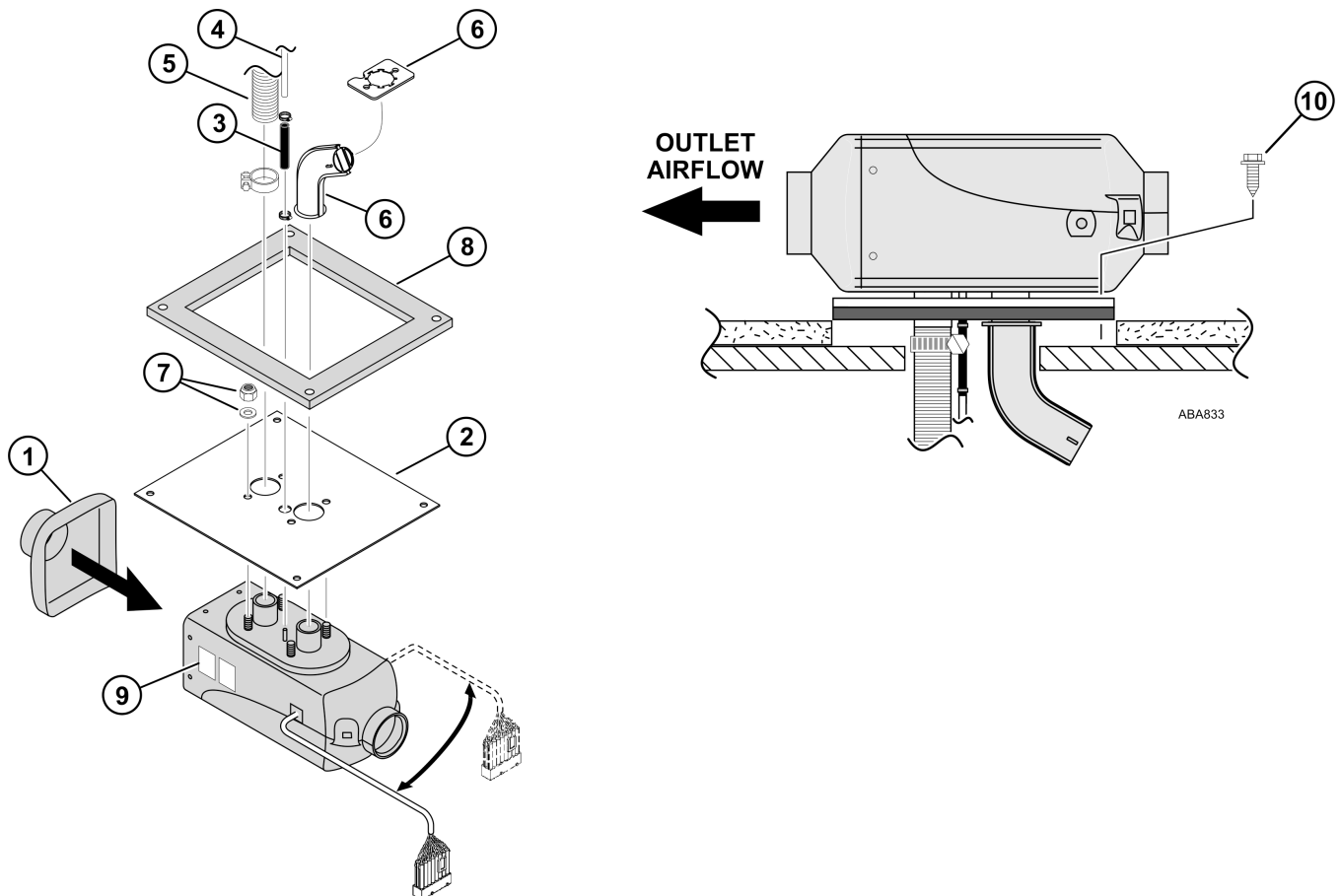



Exhaust and Combustion Air Intake Routing

⚠ Danger

Asphyxiation Hazard!

The correct installation of the exhaust and combustion air intake hoses is extremely important to prevent carbon monoxide poisoning or asphyxiation.

EXTREME CARE MUST BE TAKEN TO:

- Route the exhaust outlet hose and combustion air intake tube so they cannot be plugged by dirt, water or snow.
- Ensure the exhaust outlet and air inlet do not face into the tractor's slip stream to prevent "ram air" effect.
- Keep exhaust outlet and air intake hoses a minimum of 12" apart.
- Install exhaust hose so it will maintain a minimum distance of 2.00 inches (50.8 mm) from any heat sensitive or flammable material.
- The exhaust hose should be mounted slightly downwards to help drain off condensation.
- Install the protective cap onto the end of the exhaust hose.
- Route the exhaust hose to an open area to the rear or side of the tractor so fumes cannot build up and enter the cab or the combustion air inlet tube to the heater.
- **DO NOT** mount the exhaust hose to the tractor's frame. It must be installed to the cab to allow for movement.

Exhaust and Combustion Air Intake Installation

1. Route the exhaust hose to an open area to the rear or side of the tractor positioned slightly downwards to help drain off condensation and secure with clamps.
 - a. Drill a 1/8" hole in exhaust hose if necessary to allow for water drainage.

Note: Exhaust hose can be shortened to a minimum of 8" if required.
2. Attach metal end cap to exhaust hose.
3. Position air intake tube facing towards the rear of the tractor where it can pick up clean, fresh, moisture free air.
4. From underneath the sleeper:
 - a. Apply silicone sealant around ONLY the four heater mounting screws.
 - b. DO NOT apply any sealant around the access hole!

Important: ALWAYS VERIFY the two water valves (kazoos) are installed onto the evaporator drain tubes and are secured with hose clamps.

Figure 16. Correct Exhaust and Combustion Air Intake Routing Shown

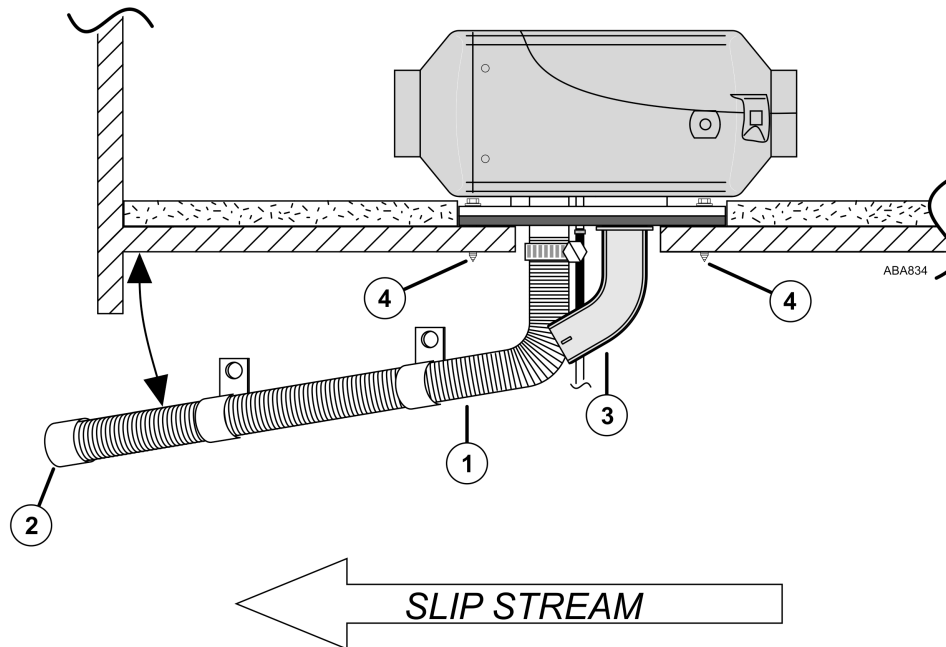

D2/D4 Heater Duct Installation

Duct Locations

Important: See “Discharge and Return Air Duct Standards” in Section 7 of the Thermo King TriPac Installation Standards Guide (TK 56498). **THESE STANDARDS MUST BE FOLLOWED!**

IMPORTANT INFORMATION:

- **USE SUPPLIED HEATER DUCT HOSE ONLY!** Do not use existing vehicle ducts or outlets. Ducts and outlets must be capable of withstanding a minimum of 300F (148.9C) operating temperatures.
- Adjustable air vent must always be installed so it cannot blow hot air directly at living creatures (people, animals) or objects sensitive to temperature.
- Do not position outlet so that it will blow hot air directly at operator or at thermostat.
- Position air outlet so that it cannot be obstructed.
- Use the supplied protective air intake grille on the air inlet side of the heater to prevent objects from being sucked in.
- Do not overtighten duct clamps.
- Do not lay or bundle the heater ducts with A/C ducts. They should not touch each other.
- Ensure provisions are made for proper air return ventilation.

The heater is equipped with a **Return Inlet** and **Discharge Outlet** for attaching the flexible heater duct hoses.

Notes: A return air duct to the heater should be provided for best heating efficiency.

- *Return Inlet must be provided to return air to the heater. It is typically mounted at the base of the bunk directly opposite the discharge outlet vent.*
- *Discharge Outlet should be located at floor level to provide maximum heating comfort in the sleeper. It is typically installed at the base of the bunk on one end.*
- *Heater ducts should be installed and routed with smooth bends and no kinks to provide maximum airflow.*

Refer to the installation procedures on the next page.

Installation Procedures

Special Tools Required
Drill Motor
3-3/4" Hole Saw (for installing ESPAR discharge air vent and return air grille)
3-1/4" Hole Saw (for routing ESPAR ducts through compartment walls if required)

Discharge Air

1. Find appropriate location for the floor level discharge air vent and drill a 3-3/4" hole using a hole saw.
 - a. Unsnap rotating outer louver assembly from mounting base.
 - b. Install base into 3-3/4" hole and secure with supplied screws.
 - c. Reinstall rotating outer louver assembly back into mounting base ring. Verify that it rotates freely.
2. Attach one end of heater duct to discharge outlet hood on heater and secure with supplied clamp.
3. Route heater duct to floor level discharge air vent, cut as needed, attach to end of plastic louver vent and secure with supplied hose clamp.

Return Air

4. If a return air duct is not used, the protective grille must be installed onto the heater inlet.
5. Find appropriate location for floor level return air grille and drill a 3.75" hole using a hole saw.
 - a. Install return air grille into hole and secure with supplied screws.
6. Attach one end of return air duct to air inlet hood on heater and secure with supplied clamp.
 - a. Route return air duct to return air grille, cut as needed, attach to end of plastic louver vent and secure with supplied hose clamp.

Refer to the illustration on the next page.

Figure 17. D2/D4 Heater Duct Installation Shown

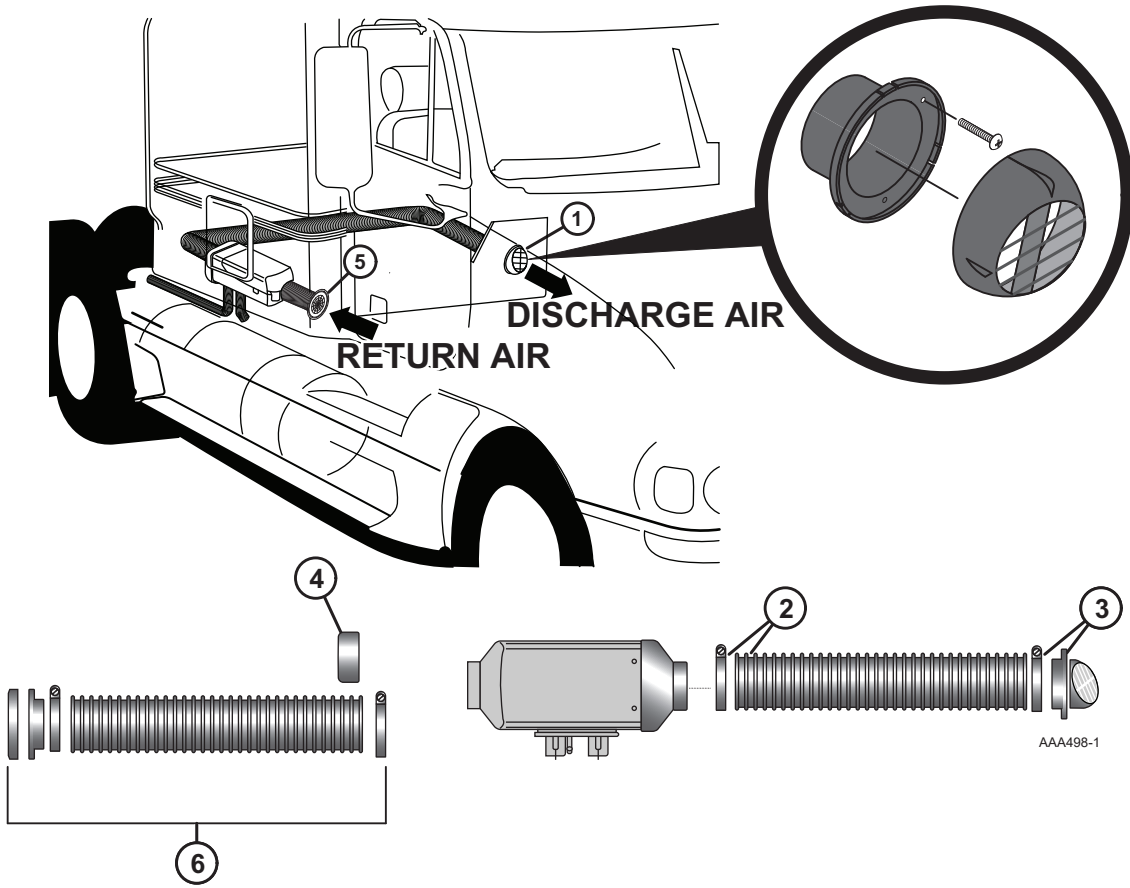

A/C Duct and Vent Installation

A/C Vent Locations

Note: See “Evaporator Air Discharge Ducts and Vents Installation Standards” in Section 6 of the Thermo King TriPac Installation Standards Guide (TK 56498). **THESE STANDARDS MUST BE FOLLOWED!**

The evaporator is equipped with two air discharge outlets to attach the supplied flexible air ducts. The ducts will be attached to plastic air vents that should be located and installed to provide maximum air circulation in the sleeper. Suggested locations of the air vents:

- **MEDIUM** (above lower bunk level)
- **HIGH** (above upper bunk level)

Note: A/C air ducts and vents are typically routed and installed through closets or storage compartments.

Important: Extreme care should always be taken when drilling holes in the various types of material found in sleepers such as plastic, steel, aluminum, and upholstery.

IMPORTANT

To maximize APU efficiencies, the back flow damper kit (710676) must be installed when connecting the TriPac’s air conditioning discharge hose (s) directly into the truck’s OEM HVAC duct(s). The damper will prevent the TriPac’s air from back flowing into the OEM HVAC housing. Failure to install this kit may result in poor system performance.

Installation Procedures

Special Tools Required
Drill Motor
4-1/4” diameter Hole Saw (for installing plastic A/C louver vents and for routing ducts through compartment walls)

1. Find an appropriate location for the A/C vents and drill 4-1/4” diameter holes.
2. Attach one end of the flexible air duct to one of the air discharge outlets of the evaporator and secure with supplied hose clamps
3. Route the flexible air duct through the A/C vent hole, cut excess duct as needed.
4. Unsnap rotating outer louver assembly from the mounting base.
5. Attach to flexible air duct to the end of the louver base with band wraps.
6. Push the mounting base back into 4-1/4” mounting hole and secure with supplied screws.
7. Reinstall rotating outer louver assembly back into the mounting base and verify that it rotates freely.
8. Install the second A/C vent in the same manner.
9. Verify flexible ducts are installed and routed with smooth bends and no kinks to provide maximum airflow.
10. Secure flexible ducts with large band wraps to prevent excess movement.

Figure 18. Typical A/C Duct Installation Shown

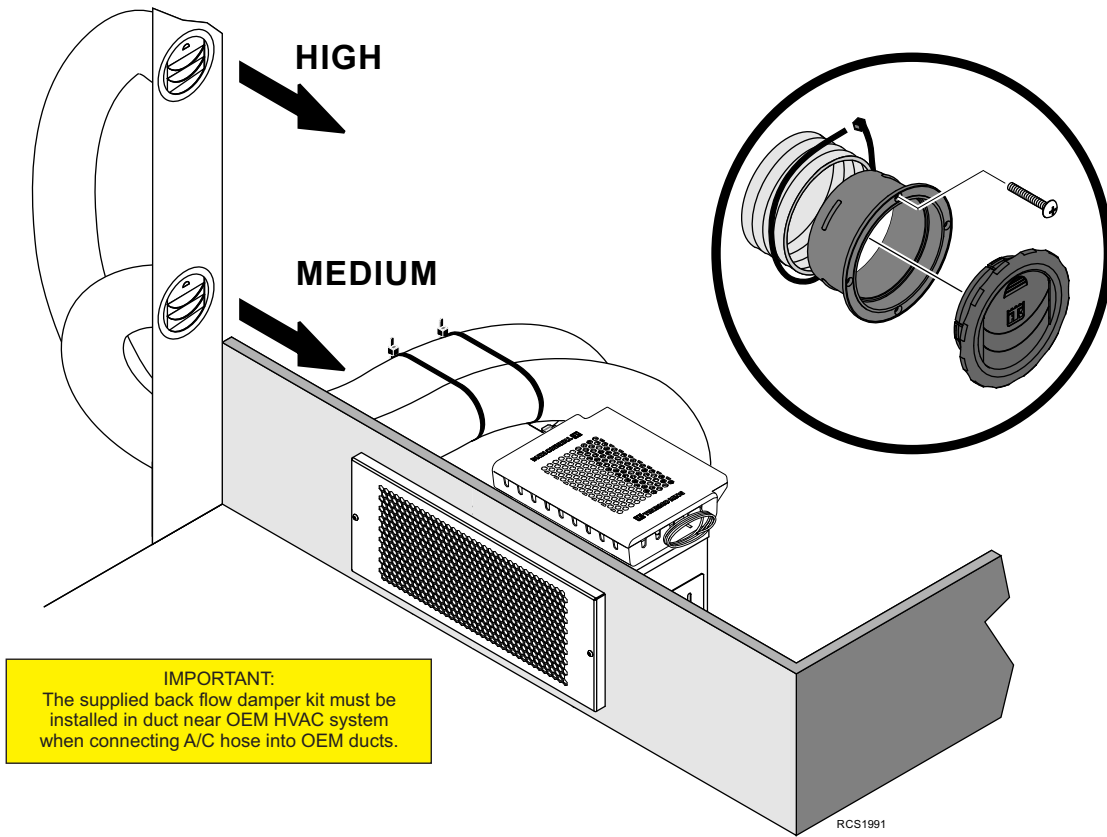
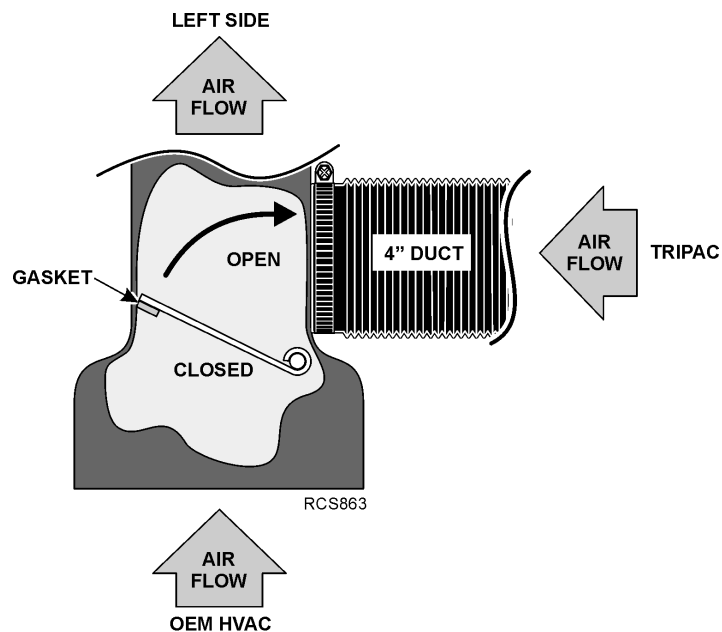

Figure 19. Example of a Back Flow Damper Shown



A/C Hose Installation

Note: See “Refrigerant Hose and Fittings Standards” in Section 8 of the Thermo King TriPac Installation Standards Guide (TK 56498). **THESE STANDARDS MUST BE FOLLOWED!**

Special Tools Required
Hose Fitting Tools (204-1045)
Hose Cutting Tool (204-677)
PAG Refrigerant Oil (2030502)
Torque Wrench

Important: Always use two wrenches while tightening refrigeration fittings.

APU Bulkhead Hose Connections

1. Begin at the rear APU bulkhead fittings and work towards the other A/C system components.
 - a. Attach a **#10, 45 degree fitting (with service port)** onto refrigerant hose and loosely connect to the **suction** bulkhead fitting.
 - b. Attach a **#8, 45 degree fitting (with service port)** onto refrigerant hose and loosely connect to the **discharge** bulkhead fitting.

Compressor to Evaporator Connections

2. From the APU, route the **#10 suction hose** up through the 3” access hole in the tractor floor to the evaporator:
 - a. Cut the hose to the appropriate length, attach a **#10 fitting** and connect to the #10 suction fitting on the evaporator

APU to Condenser Connections

3. From the APU, route the **#8 discharge hose** to the condenser coil:
 - a. Cut the hose to the appropriate length, attach a **#8 fitting** and connect to the #8 discharge fitting located near the top of the condenser coil.

Evaporator to Receiver Drier Connections

4. Fabricate a **#6 hose** and fitting and attach onto the **#6 liquid line fitting** on the evaporator:
 - a. Route the hose down through the 3” access hole in the tractor floor to the receiver drier.
 - b. Cut the hose to the appropriate length, attach a **#6 fitting** and connect to the **OUTLET** end indicated by arrow on the receiver drier.

Condenser to Receiver Drier Connections

5. Fabricate a **#6 hose** and fitting and attach onto the **#6 fitting** on the condenser coil:
 - a. Route the hose to the receiver drier.
 - b. Cut the hose to the appropriate length, attach a **#6 fitting** and connect to the **INLET** end on the receiver drier.
6. Use a torque wrench and tighten all fittings as specified in the chart.

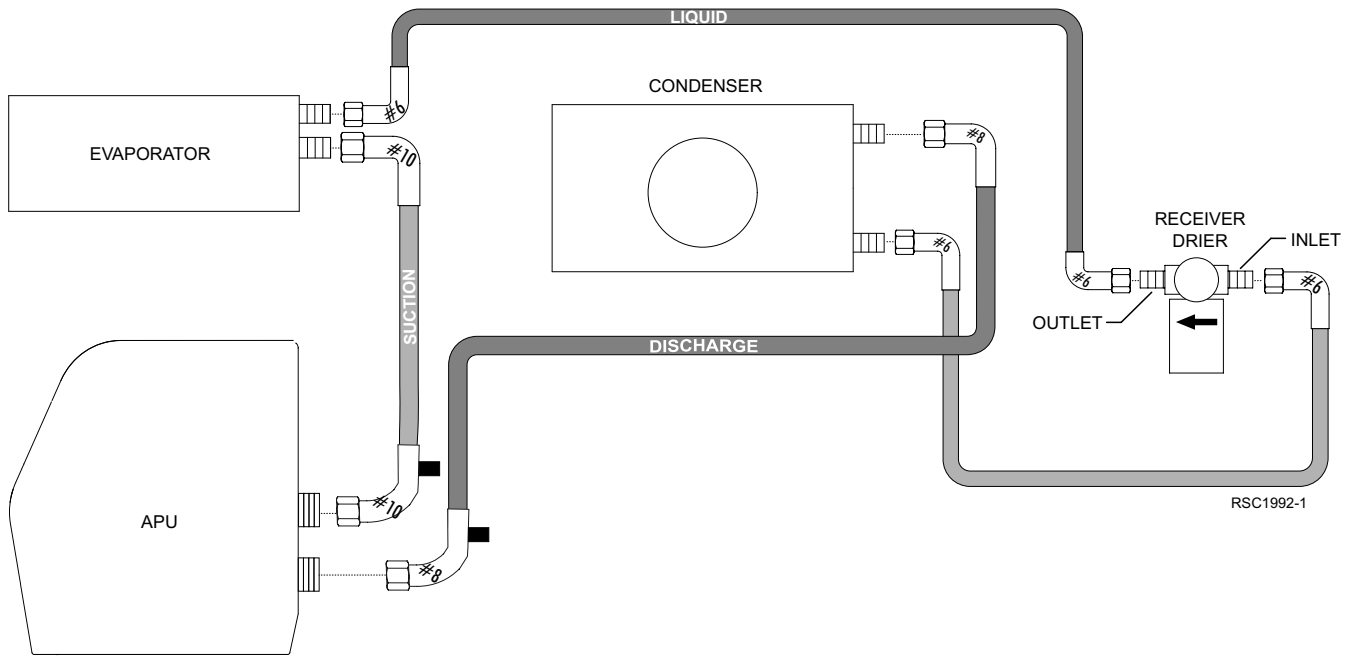
Figure 20. A/C Hose Diagram and Torque Specifications Shown

Fitting Size	Torque Specifications
#6 (3/8")	11-13 lb-ft (15-17 N•m)
#8 (1/2")	15-20 lb-ft (20-27 N•m)
#10 (5/8")	21-27 lb-ft (28-37 N•m)

A/C System Evacuation and Leak Check Procedures

Evacuation Procedures

Note: See “System Evacuation Standards” in Section 12 of the Thermo King TriPac Installation Standards Guide (TK 56498). **THESE STANDARDS MUST BE FOLLOWED!**

Evacuation Procedures
Thermo King Evacuation Station (P/N 204-725) Recommended
Evacuation Station Operation and Field Application Instructions (TK 40612)
Electronic Leak Detector (204-756)
Gauge Set with R134a Adapters

Note: The oil in the evacuation station vacuum pump should be changed after each use.

Important: Always use recommended vacuum equipment. Before each use, check that there are no leaks in the vacuum equipment either in the pump itself or in the hoses.

1. Connect the gauge manifold to the service ports on the suction and discharge hoses.
2. Connect the service line of the gauge manifold to the vacuum pump and micron gauge.
3. Open the gauge manifold and vacuum pump valves and gauge manifold hand valves
4. Start the vacuum pump and evacuate until system reaches 500 microns.
5. Once the system reaches 500 microns, continue evacuation for one additional hour.

Note: To save installation time, while the system is being evacuated, continue on to the electrical installation beginning with “Control Box and Main Harness Installation”. Return and complete this procedure later.

6. Close the vacuum pump valve, switch off the pump, checking that the gauge reading for the vacuum pump does not exceed 2000 microns in the following five minutes. If vacuum level exceeds 2000 microns before five minutes, and continues to rise, proceed to the **Leak Check Procedures** section below.
7. If vacuum level remains below 2000 microns for 5 minutes the system is leak free and ready to be filled with refrigerant
8. Close manifold hand valves and remove evacuation equipment.

Leak Check Procedures

Note: See “System Leak Check Standards” in Section 12 of the Thermo King TriPac Installation Standards Guide (TK 56498). **THESE STANDARDS MUST BE FOLLOWED!**

1. Add vapor R-134a to the unit until bottle pressure is reached.
2. Thoroughly leak check the system with an electronic leak detector.
3. If leak(s) are found, recover leak check charge.
4. Repair any leaks and re-evacuate system.

Figure 21. Gauge Manifold and Vacuum Pump Shown Connected to APU

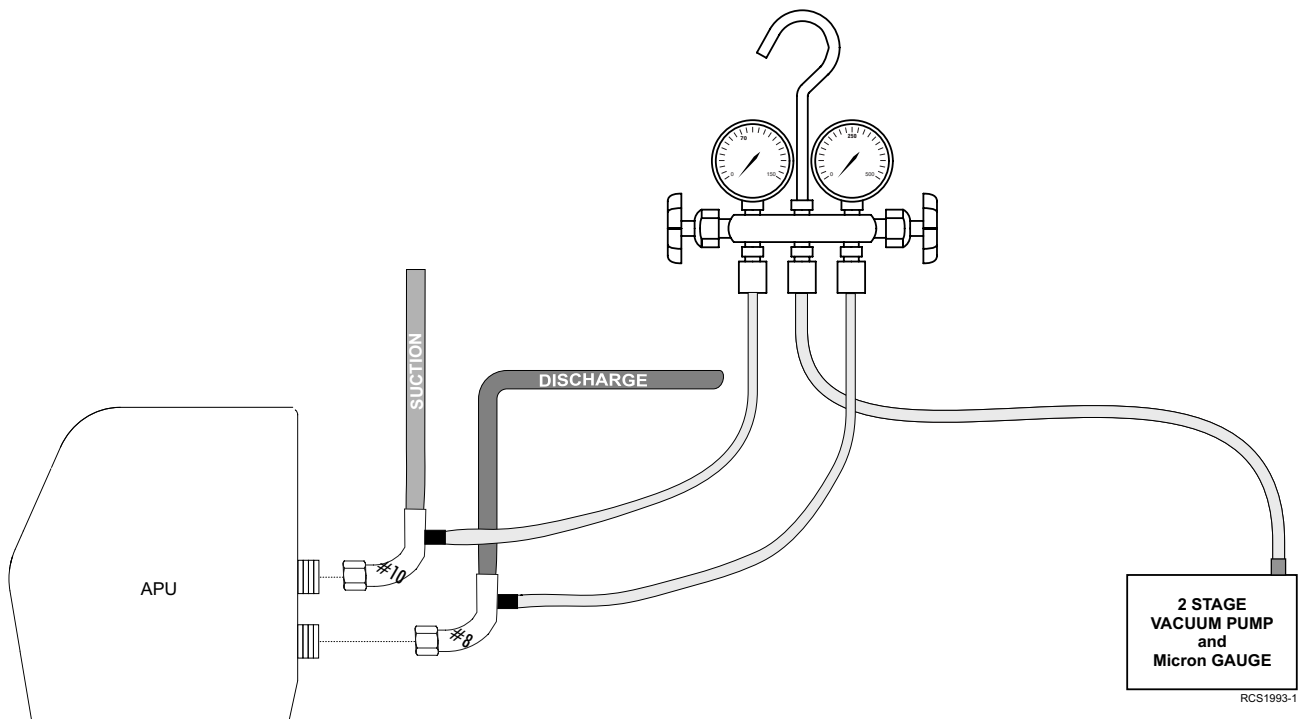

CONTINUE WITH THE INSTALLATION WHILE THE UNIT IS BEING EVACUATED

Main Harness Installation

Note: All interior electrical connections are made at the MAC.

1. From the APU, route the following harnesses up through the access hole and into the sleeper. Connect to the mating connectors on the MAC as shown:
 - Power/Ground 2-pin connector (**MAC PWR, MAC GND**)
 - Cond/Can 6-pin connector (**COND FAN 2, COND FAN RTN 1, CANIH RIO 1, CANIL RIO 1**)

Figure 22. All TriPac 3 Electrical Connections to MAC Shown

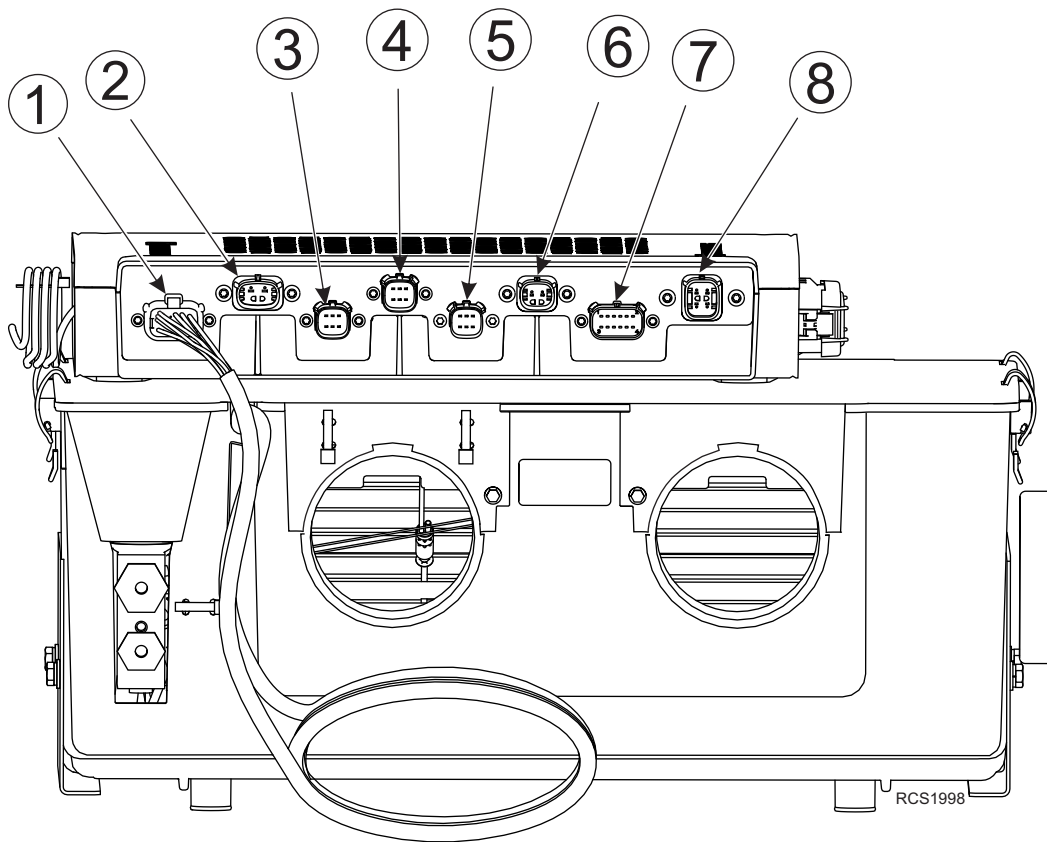

1.	Evaporator	5.	HMI
2.	Power/Ground	6.	Truck Integration (option)
3.	Condenser/CAN	7.	Heater
4.	Telematics (option)	8.	Hourmeter (option)

HMI Controller Installation

HMI LOCATION

- Choose a location inside the truck's sleeper that is easily accessible and visible from the drivers bunk.
- To accurately measure inside air temperature, mount the HMI away from windows, air vents, and out of direct sunlight.
- HMI harness is typically routed through an access hole in the interior wall to the MAC. Keep this in mind when choosing the location for the HMI.

Note: Refer to the illustrations.

1. Remove HMI from mounting bracket.
2. Use mounting bracket as a template.
 - a. Position mounting bracket on interior wall making sure the **UP** arrow is facing up and the bracket is level.
 - b. Mark location of the four mounting holes and remove mounting bracket.

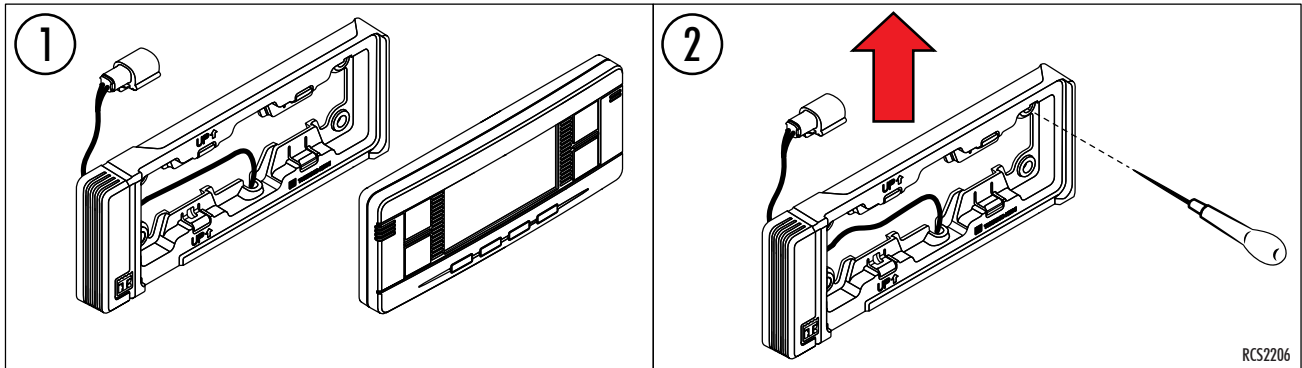

3. Measure and mark the C/L for the access hole.
 - a. Drill (4) mounting holes per the size of mounting fasteners being used.
 - b. Use a hole saw and drill (1) 1-1/4 in. access hole, located right of center, see image below.
4. Attach HMI harness connectors as shown:
 - a. 2-pin connector to connector on back of mounting bracket.
 - b. 8-pin connector to back of HMI.
 - c. Push locking tab on connector into place and then slide locking tab on HMI to secure connector.
 - d. Route HMI harness through the access hole, behind the interior wall to the MAC.

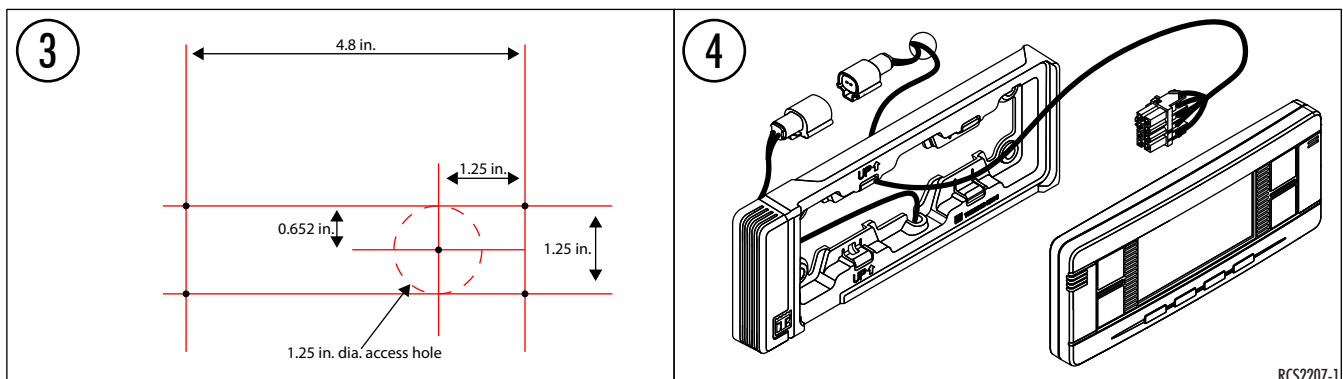

5. Secure mounting bracket to wall with installer supplied hardware.
 - a. Reinstall HMI onto mounting bracket.
6. Attach HMI 6-pin harness connector to mating HMI connector on the MAC.
 - a. Neatly bundle and secure any excess harness.

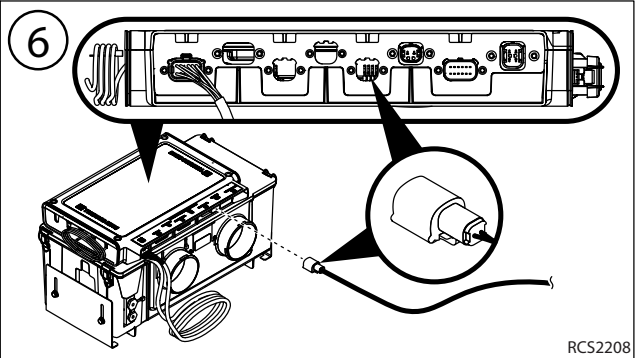
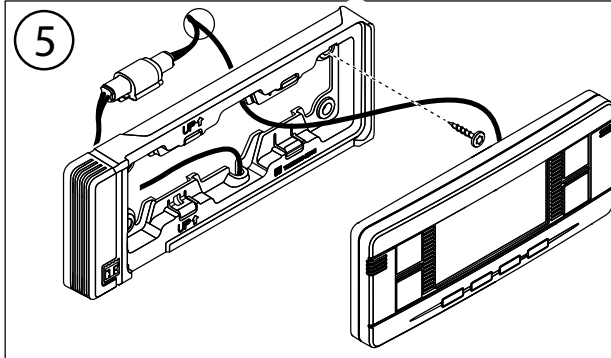

RCS2208

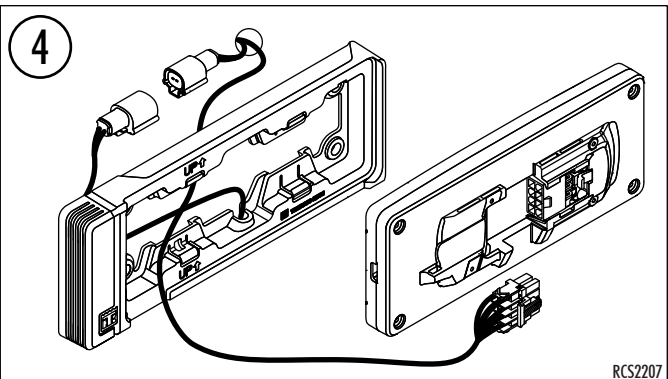
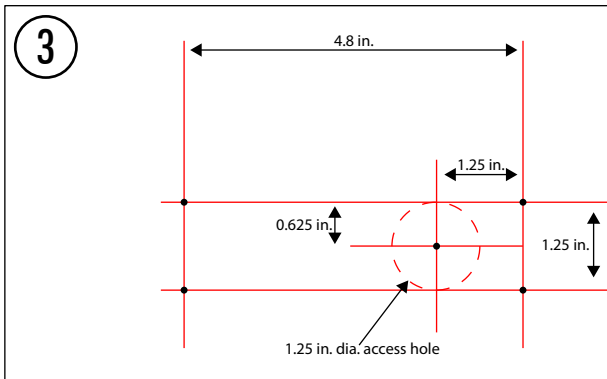

RCS2207

Heater Fuel Pump Connections

⚠ Caution

Risk of Injury!

To prevent the APU from starting unexpectedly, set all electrical controls to the OFF position BEFORE connecting wires to battery.

1. Route the heater fuel pump harness to the heater fuel pump.
2. **DO NOT** connect the fuel pump harness to the fuel pump at this time. The fuel pump harness will be attached later after the fuel pump has been primed.
3. Connect heater harness to the assigned MAC controller connection location.

Figure 23. Heater Fuel Pump Connections Shown

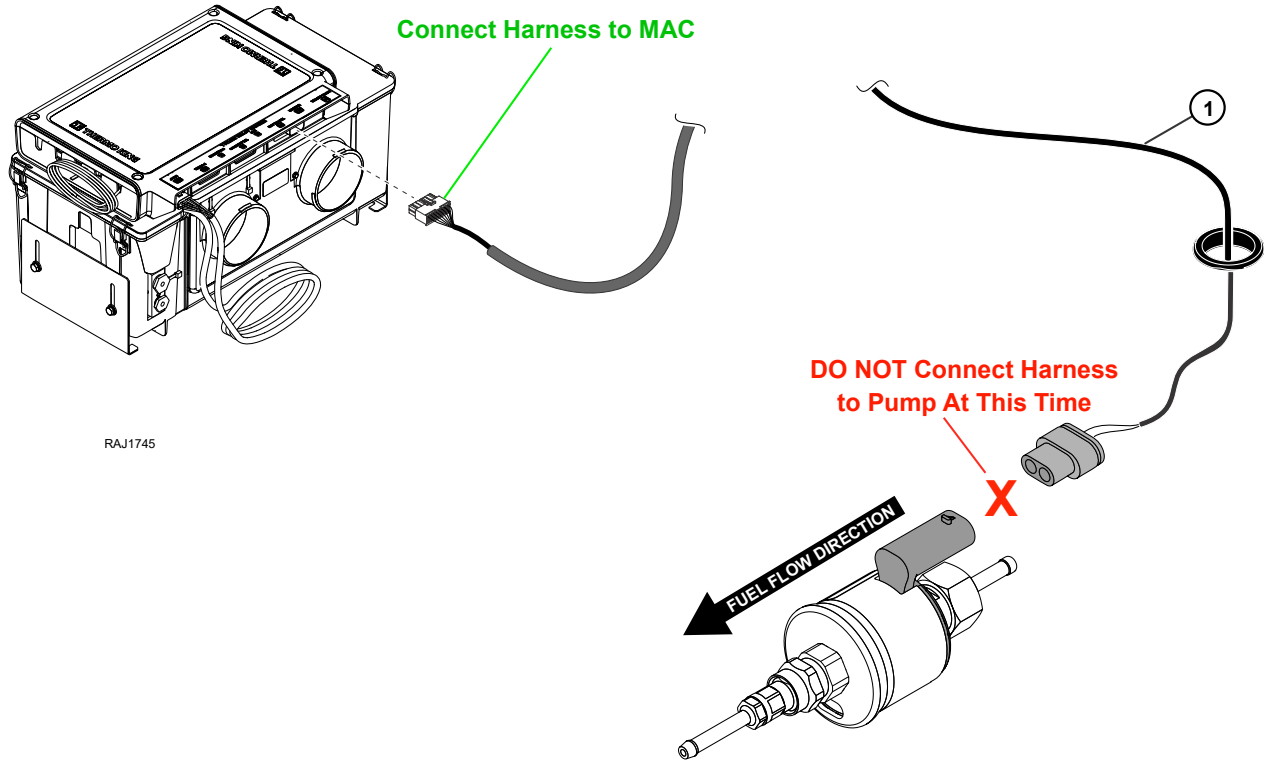

RAJ1745

Fuse Holder and APU Battery Connections

Power Inverter Option Only — Route and connect the power inverter cables to the battery and fuse holder now. Refer to TK 56837-8-IM.

Important Battery Cable Installation Information

Important: Do not attach both the positive and the negative cables to a single battery. For best results, attach the positive cable to the first battery and the negative cable to the last battery as shown.

1. FUSE HOLDER

- a. Mount fuse holder securely to battery box structure with (installer supplied) 1/4-20 hardware within 12.0 inches (304.8 mm) of positive battery terminal. It is not acceptable to leave fuse holder loose or tied to other cabling.
- b. **DO NOT** install fuse at this time.

2. POSITIVE BATTERY CABLE AND VOLTAGE SENSING WIRE

- a. Route positive cable with voltage sensing wire from TriPac to fuse holder.
- b. Cut battery cable to length and strip 1/2 to 3/4 in. (13 to 19 mm) of insulation from cable end.
- c. Slide heat shrink tubing and terminal ring with **small hole** onto end of cable. Attach terminal ring firmly to cable.
- d. Position heat shrink tubing to cover exposed wires on terminal ring and use a heat gun to shrink tubing in place.
- e. Install cable onto fuse holder stud and only hand tighten nut.
- f. Cut voltage sensing wire to length, strip end, attach in-line fuse with splice connector.
- g. Slide heat shrink tubing and terminal ring onto other end of in-line fuse. Attach terminal ring firmly to wire.
- h. Position heat shrink tubing to cover exposed wires on terminal ring and use a heat gun to shrink tubing in place. This wire will be attached in the step 3.

3. SHORT POSITIVE BATTERY CABLE

- a. Fabricate short cable (from the excess positive cable) that reaches from the battery positive terminal to fuse holder and strip 1/2 to 3/4 in. (13 to 19 mm) of insulation from cable ends.
- b. Slide heat shrink tubing and terminal ring with **small hole** onto end of cable. Attach terminal ring firmly to cable.
- c. Slide heat shrink tubing and terminal ring with **large hole** onto other end of cable. Attach terminal ring firmly to cable.
- d. Position heat shrink tubing to cover exposed wires on terminal rings and use a heat gun to shrink tubing in place.
- e. Install battery cable end with **small hole** terminal ring followed by the voltage sensing wire onto the fuse holder stud and only hand tighten nut.
- f. Install battery cable end with **large hole** terminal ring connector onto the battery's **POSITIVE (+)** connection and tighten securely.
- g. Apply Superlube (PN 203-524) onto the battery's connection.

4. NEGATIVE BATTERY CABLE

- a. Route negative cable from TriPac to tractor's negative battery, cut to length and strip 1/2 to 3/4 in. (13 to 19 mm) of insulation from cable end.
- b. Slide supplied heat shrink tubing and terminal ring onto end of cable. Attach terminal ring firmly to end of cable.
- c. Position heat shrink tubing to cover exposed wires on terminal ring and use a heat gun to shrink tubing in place.
- d. Install negative cable terminal lug onto the battery's **NEGATIVE (-)** connection and tighten securely.
- e. Apply Superlube (PN 203-524) onto the battery's connection.

5. FUSE

- a. Remove nuts from fuse holder and place fuse onto the studs and on top of sensing wire and battery cables lugs, then reinstall nuts.
- b. Tighten the nuts to 120 in-lb (13.5 N•m) and close the fuse holder cover securely.



THERMO KING

Fuse Holder and APU Battery Connections

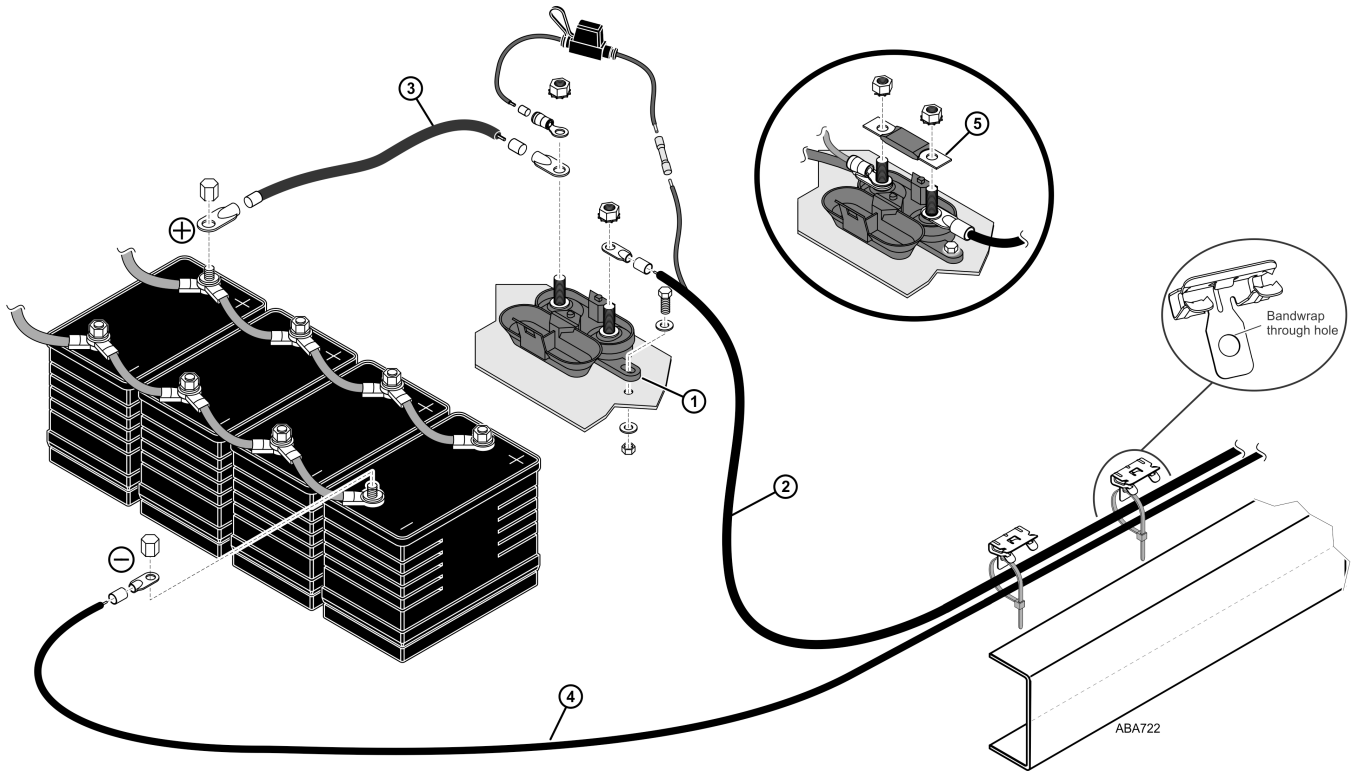

HMI Flash Loading Procedures

Important: New TriPac 3 installation require the HMI to be flashloaded with the operating software. This procedure may take 45 minutes to 1 hour to complete. Once the procedure is started **DO NOT** push any buttons, power off, or disconnect the HMI. Doing so will cause the download to fail.

Important: All TriPac 3 units built on or after **September 28th, 2023** are shipped with a pre-flashloaded HMI. HMI flashloading is not required on units built on or after **September 28th, 2023**.

1. Press the **ON** button – **Bootloader Mode** will appear on the HMI screen for approximately 45 minutes. **See note above.**



Flash-loading in progress will appear next.

Important: This screen may be seen for approximately 5 minutes. **DO NOT** power off or disconnect the HMI while flashload is in process. Doing so will cause the download to fail.



Flashload Success will then appear indicating the flashload was successful.

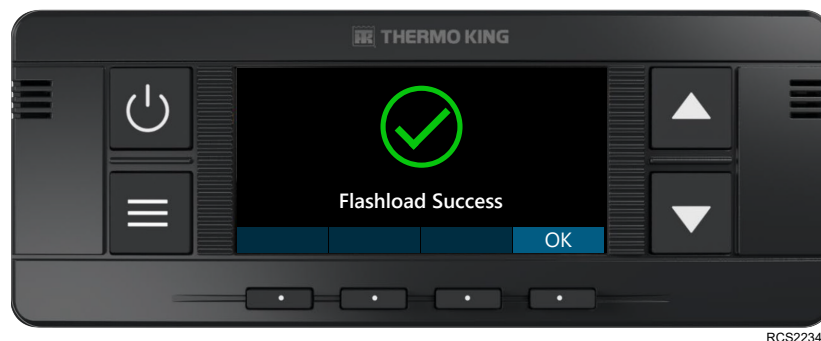

2. Press the **OK** button.
3. Press the **OFF** button.

The HMI is now fully operational.

A/C Wiring Installation

1. At the APU, locate the condenser fan and receiver drier binary switch harness. Route harness to the condenser fan.
 - a. Attach 2-pin connector (COND FAN 2, COND FAN RTN 1) to condenser fan.
 - b. Attach 2-pin connector (HPCO AC CLUTCH PWR 2, HPCO RTN 1) to receiver drier binary switch.
2. Secure all harness adequately.

Note: Excessive harnesses lengths should be doubled up and secured with band wraps. DO NOT CUT THE WIRE HARNESES!

Figure 24. Condenser Fan and Binary Switch Connections Shown

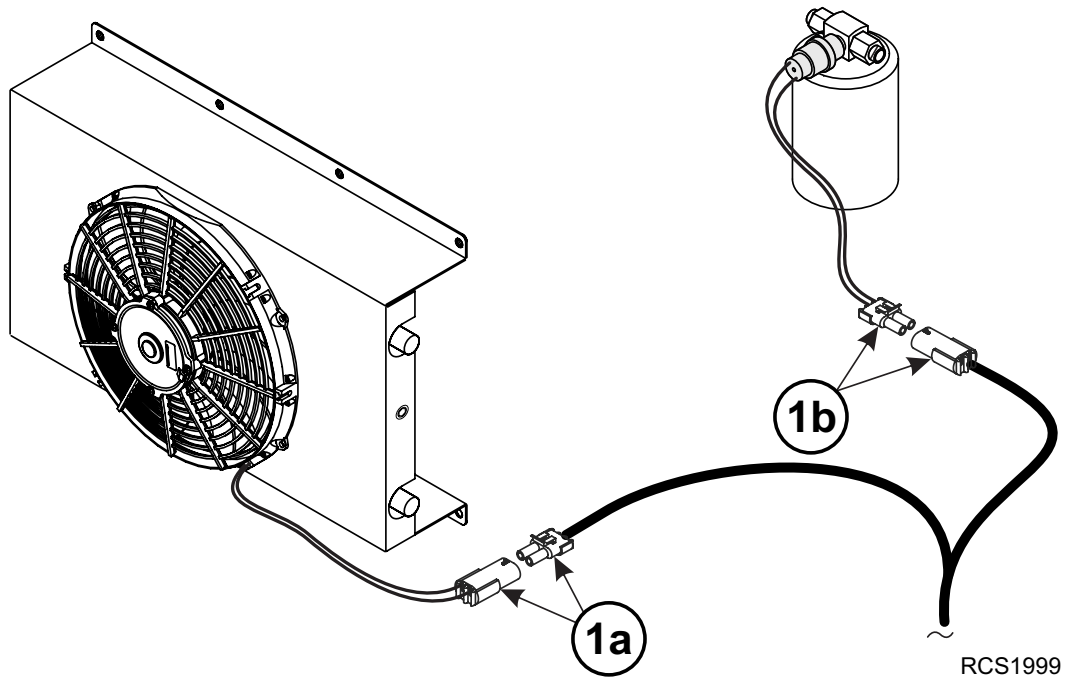

Standby Truck Integration Harness without Switch (Option)

Special Tools Required
Digital Meter (204-615)

1. Access truck's ignition switch wires at rear of switch:
 - a. Turn ignition switch to the "ACCESSORY" position and use a digital meter to locate a wire connection with **NO POWER (0 Vdc)**.
 - b. Turn ignition switch to the "ON" position and re-check for voltage at the same wire connection tested earlier. If voltage is present, this is where the **IGN** wire will be connected.

Connect IGN wire to:	"ON" circuit of ignition switch or "ON" circuit of fuse panel
-----------------------------	---

2. Route standby switch harness to the **MAC** and attach to **TRUCK INTGRTN** connection.

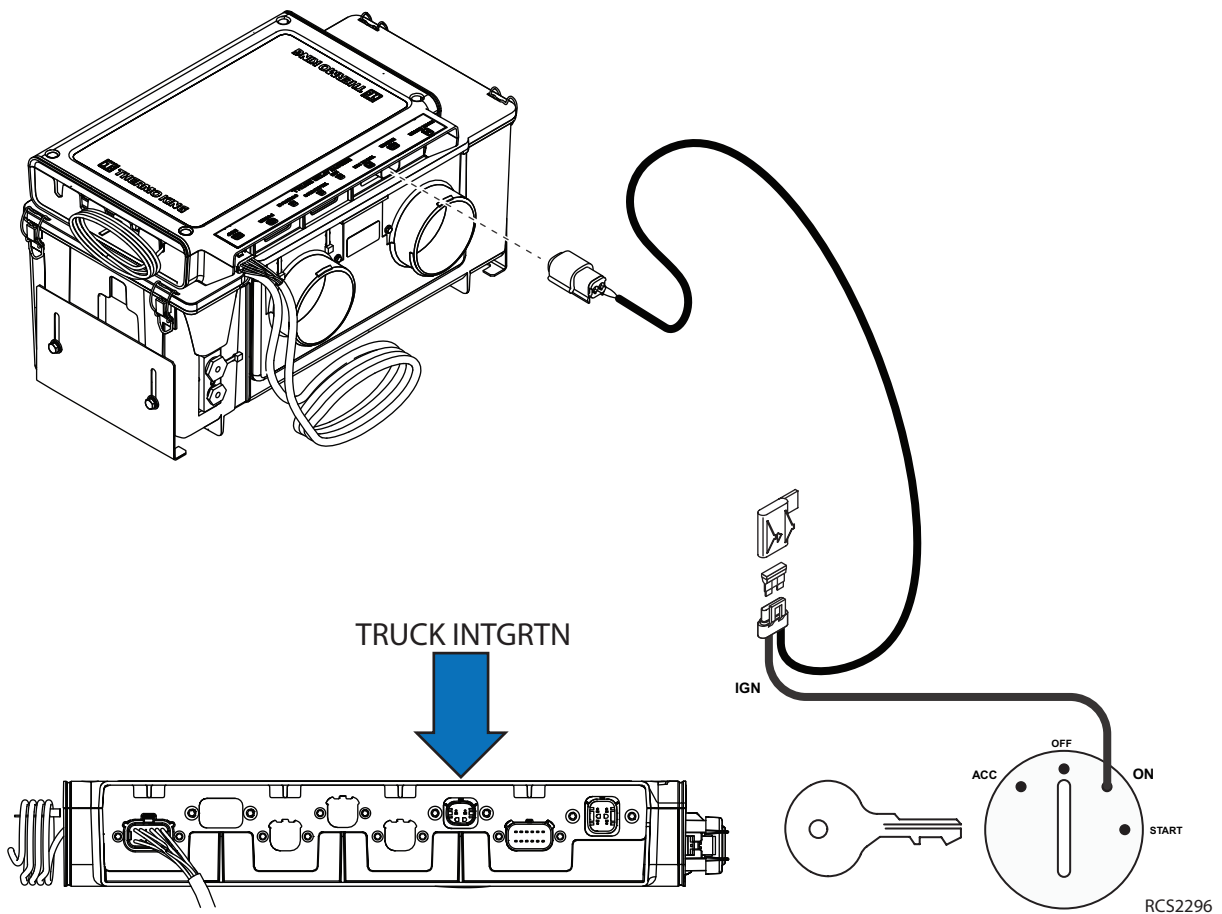

Standby Truck Integration Harness with Switch (Option)

Special Tools Required
Digital Meter (204-615)
Drill Motor with 1/2" Drill Bit

1. Access truck's ignition switch wires at rear of switch:
 - a. Turn ignition switch to the "ACCESSORY" position and use a digital meter to locate a wire connection with **NO POWER (0 Vdc)**.
 - b. Turn ignition switch to the "ON" position and re-check for voltage at the same wire connection tested earlier. If voltage is present, this is where the **IGN** wire will be connected.

Typically the standby switch is installed in the dashboard in a location that is easily accessible for the driver.

2. Remove dash panel (if required). Mark and drill 1/2" hole.
3. Install standby switch, nameplate and nut. Confirm the 2 A wire on switch is facing **UP** and then tighten nut securely.
4. Connect **IGN** wire with in-line fuse to:

Connect IGN wire to:	"ON" circuit of ignition switch or "ON" circuit of fuse panel
-----------------------------	---

5. Route standby switch harness to the **MAC** and attach to **TRUCK INTGRTN** connection.

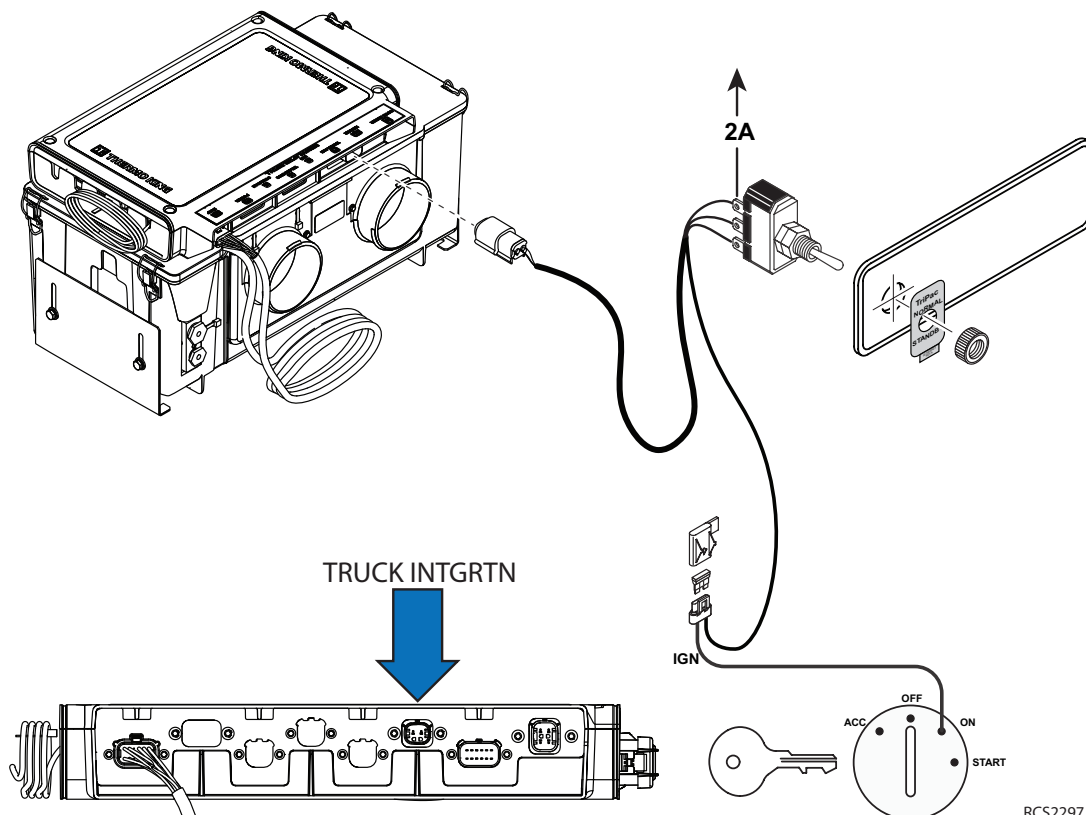

RCS2297

Fuel Pickup Tube Installation

Preferred Installation – Optional Adapter Plate (100379)

Note: Some OEM's offer a fuel tank option which provides three auxiliary fuel fitting connections. With this option, the fuel pickup tube and adapter plate are not needed. Simply route and connect the APU's fuel supply and return lines and the heater's fuel supply line to these fittings. Always check your fuel tank for these fittings before installing the fuel pickup tube or adapter plate.

⚠ Danger

Hazard of Explosion!

Use caution when working in or around the area of the diesel fuel tank. Diesel fuel vapors are potentially explosive. Do not smoke while working near the diesel fuel tank.

The following installation is for OEM fuel tanks equipped with an auxiliary fuel level sender (FLS) 5 bolt mounting flange.

Special Tools Required
Tape Measure
Tubing Cutter
Torque Wrench

IMPORTANT INSTALLATION TIPS

- Identify and mark APU FUEL SUPPLY pickup tube for reference later.
 - Remove protective caps from ends of pickup tubes prior to installation.
 - Do not apply any type of sealant material to fuel pickup assembly. Doing so will result in plugged fuel lines.
1. Locate auxiliary FLS mounting flange and block off plate on tractor's fuel tank. Remove block off plate and clean surface area of all dirt, grease, etc.
 2. Install adapter plate 100379 (counter sunk holes facing up) and the gasket. Secure with the supplied screws and torque to 90 lb-in. (10.2 N•m) maximum.
 3. The APU diesel engine fuel supply tube is 24" and heater fuel supply tube is 23".
 - a. Measure and cut APU diesel fuel supply tube 2" shorter than fuel tank diameter.
 - b. Measure and cut heater fuel supply tube 3" shorter than fuel tank diameter. The heater fuel supply tube is identified by not having a fitting.
 4. Loosen and slide the hardware to top of the pickup tube assembly.
 5. Spread pickup tubes approximately 12" apart then squeeze pickup tubes back together and insert tubes and bushing into hole of adapter plate.
 6. Tip back-up washer and insert into hole of adapter plate.
 - a. With back-up washer on underside of adapter plate, thread nut onto bushing and hand tighten.
 - b. OPTION - Install supplied fuel pump bracket for fuel heater.
 - c. Position pickup tube as needed to facilitate fuel line connections and tighten nut to 16 to 18 ft-lb. (21 to 24 N•m).
 7. Install supplied warning nameplate onto fuel tank in a visible area near fuel cap.

Figure 25. Optional Adapter Plate Installation Shown

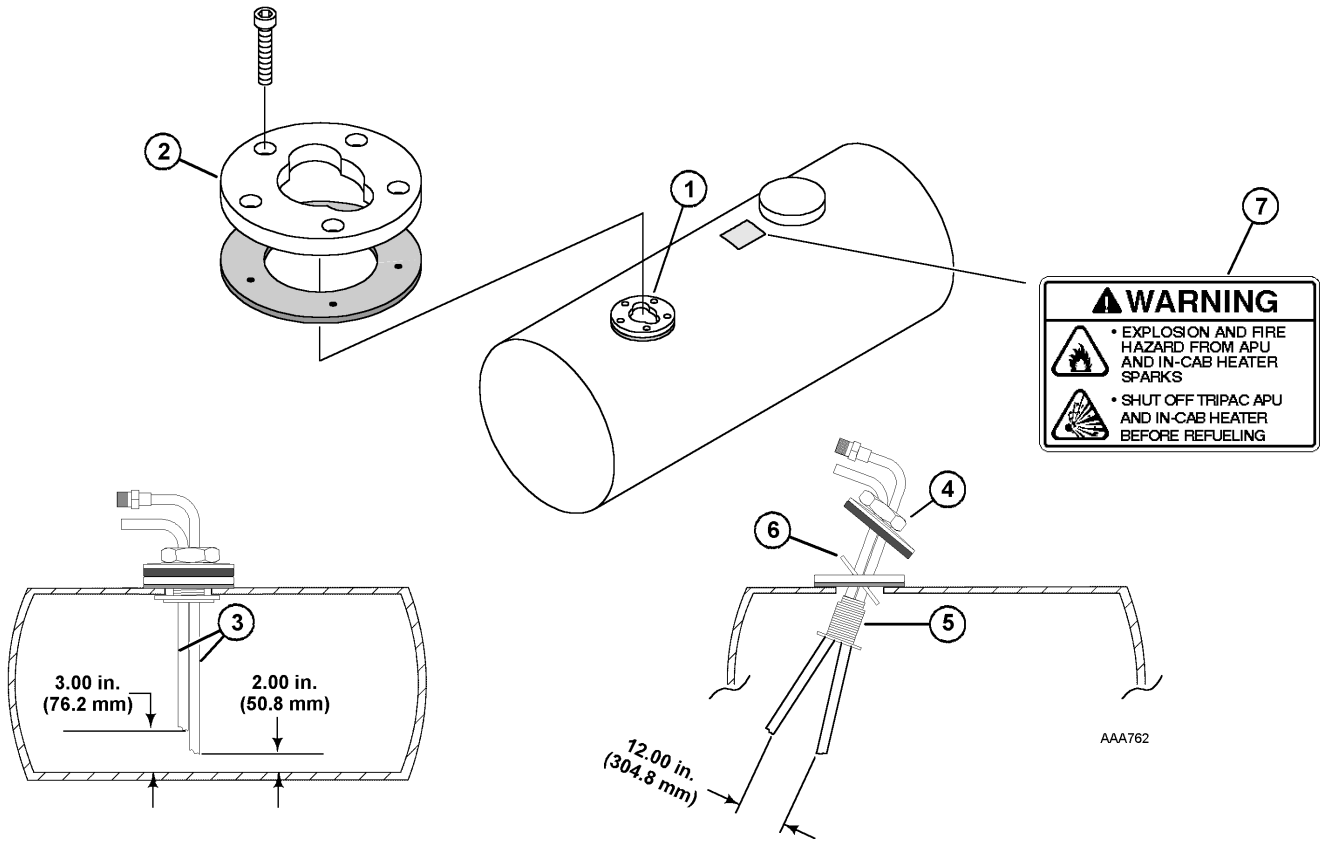

Alternative Installation – Drilling Hole In Fuel Tank

Note: Some OEM's offer a fuel tank option which provides three auxiliary fuel fitting connections. With this option, the fuel pickup tube and adapter plate are not needed. Simply route and connect the APU's fuel supply and return lines and the heater's fuel supply line to these fittings. Always check your fuel tank for these fittings before installing the fuel pickup tube or adapter plate.

Danger

Hazard of Explosion!

Use caution when working in or around the area of the diesel fuel tank. Diesel fuel vapors are potentially explosive. Do not smoke while working near the diesel fuel tank.

Danger

Hazard of Explosion!

Diesel fuel vapors are potentially explosive. Use extreme caution when drilling holes in or around diesel fuel tanks. Sparks from an electric drill or drill bit could cause an explosion. Drain all diesel fuel from the tank and use nitrogen or an inert gas to purge the diesel vapors from the tank prior to drilling into or around the fuel tank. Keep the diesel fuel tank filled with inert gas while drilling.

Special Tools Required
Tape Measure
Drill Motor
Step Reamer Bit
1-1/4" Hole Saw
Tubing Cutter
Heavy Grease
Torque Wrench

IMPORTANT INSTALLATION TIPS

- Identify and mark APU FUEL SUPPLY pickup tube for reference later.
 - Remove protective caps from ends of pickup tubes prior to installation.
 - Do not apply any type of sealant material to fuel pickup assembly. Doing so will result in plugged fuel lines.
 - Check for internal baffles in fuel tank BEFORE drilling any holes.
1. Tape paper template (supplied with pickup tube) onto tractor's fuel tank and center punch three holes. Remove template from tank.
 2. Drill a 1/4" pilot hole then drill:
 - a. 1/2" diameter outer holes first with step reamer.
 - b. 1-1/4" diameter inner hole next with hole saw.
 - c. Thoroughly clean and flush the tank to remove any chips.
 3. The APU diesel engine fuel supply tube is 24" and the heater fuel supply tube is 23".
 - a. Measure and cut APU diesel fuel supply tube 2" shorter than fuel tank diameter.
 - b. Measure and cut heater fuel supply tube 3" shorter than fuel tank diameter. The heater fuel supply tube is identified by not having a fitting.
 4. Loosen and slide hardware to top of pickup tube assembly.
 5. Spread pickup tubes approximately 12" apart then squeeze pickup tubes back together and insert tubes and bushing into hole of adapter plate.
 6. Tip back-up washer and insert it to fuel tank hole.

Fuel Pickup Tube Installation

- a. With back-up washer on underside of fuel tank hole, thread nut onto bushing and hand tighten.
 - b. OPTION - Install supplied fuel pump bracket for fuel heater.
 - c. Position pickup tube as needed to facilitate fuel line connections and tighten nut to 16 to 18 ft-lb. (21 to 24 N•m).
7. Install supplied warning nameplate onto fuel tank in a visible area near fuel cap.

Figure 26. Alternative Installation Drilling Hole In Fuel Tank Shown

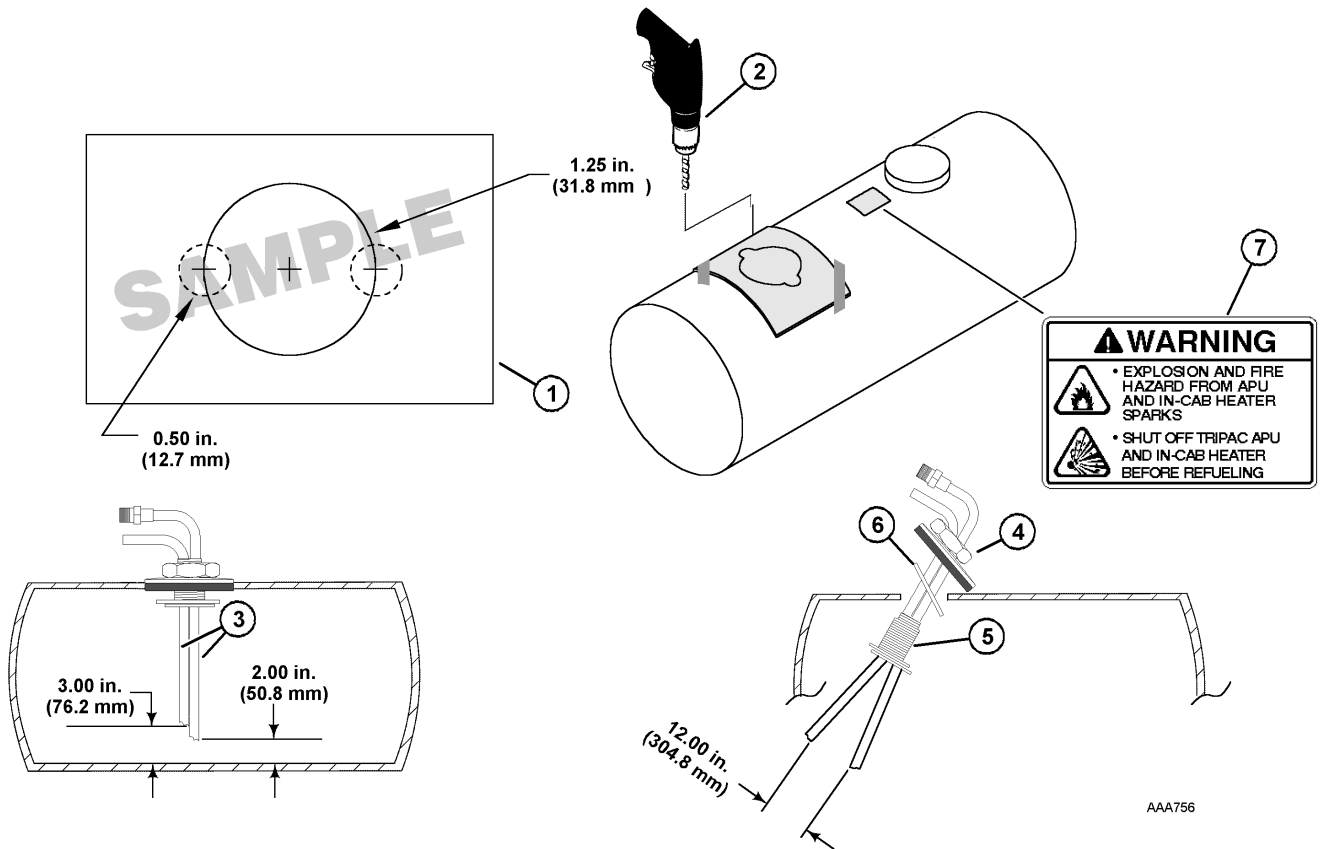

AAA756

Heater Fuel Pump and Fuel Line Installation

Special Tools Required
Utility Knife
Hose Cutting Tool 2040677

Important: Proper mounting angle of the fuel pump is necessary to allow any air or vapor in the fuel lines to pass through the pump rather than cause a blockage (Detail's A and B).

The fuel pump can be installed using either the L-bracket or the fuel tank mounting bracket (both are supplied).

L-Bracket Installation Procedures

1. Choose a protected mounting location close to the fuel pick-up tube and heater.
2. Install the fuel pump into the supplied rubber mounting clamp and attach the L-bracket.
3. Position the fuel pump at a 15 to 35 degree angle with the outlet end facing up (outlet end has connector and smaller barb fitting) and secure the clamp and bracket. **(Detail A)**.

Fuel Tank Bracket Installation Procedures

1. Loosen the fuel pickup tube nut and position the supplied fuel pump bracket under the nut then re-tighten the nut to 16 to 18 ft-lb. (21 to 24 N•m).

Note: The bracket goes under the nut, not under the washer or rubber gasket.

2. Install the fuel pump into the supplied rubber mounting clamp and attach the rubber clamp to the tank mounted bracket securely.

Fuel Line Installation Procedures

1. Attach the rubber hose connection to the outlet end of the fuel pump and secure with supplied hose clamp.
2. Route the plastic fuel line (installed earlier on the heater) to the fuel pump and cut to length. Insert the fuel line into the rubber hose connection until it butts up tight with the fuel pump's outlet pipe **(Detail B)**. Secure with supplied hose clamp.
 - The fuel line must be installed correctly to prevent air bubbles **(DETAIL B)**.
 - The fuel line from the pickup tube, to fuel pump, to heater should be routed at a continuous rise.
 - Only use a hose cutter or utility knife to cut plastic fuel lines. Do not use a wire cutter as this will pinch the plastic fuel line closed.
3. Attach fuel line from the fuel pick-up supply to the inlet end of the fuel pump and secure with supplied hose clamp.

Note: The heater fuel pickup supply tube is identified by not having a fitting.

Figure 27. Heater Fuel Pump and Fuel Line Installation Shown

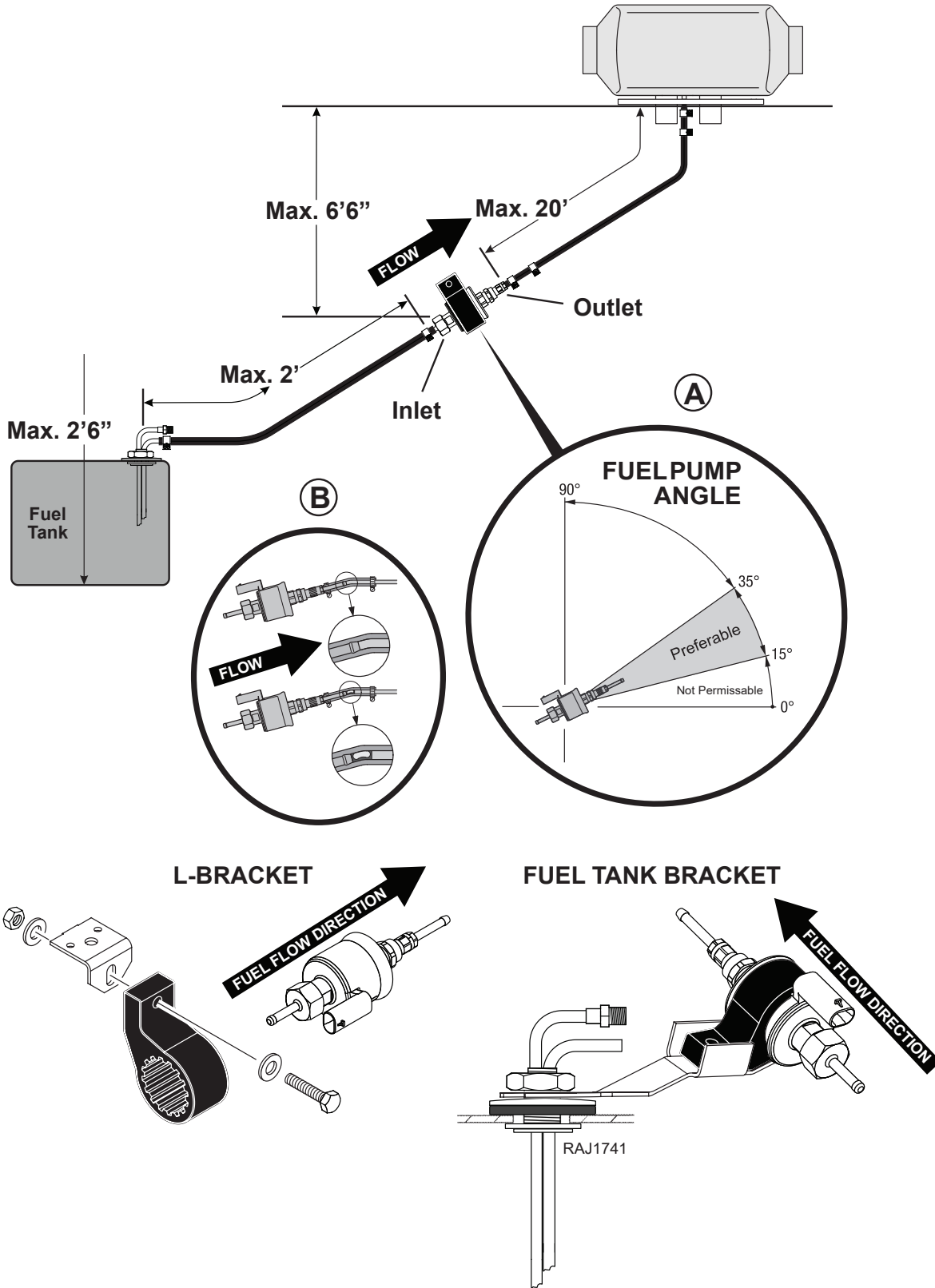

APU Fuel Line Installation

Special Tools Required
Utility Knife

Note: Be sure to connect the APU's fuel supply line to the fuel **SUPPLY** pickup tube connection identified and marked earlier

1. Route APU fuel supply line to **SUPPLY** connection of fuel pickup tube, cut to proper length and attach with compression fittings.
2. Route APU fuel return line to **RETURN** connection of fuel pickup tube, cut to proper length and attach with compression fittings.
3. Route and secure all fuel lines with adequate clamps.

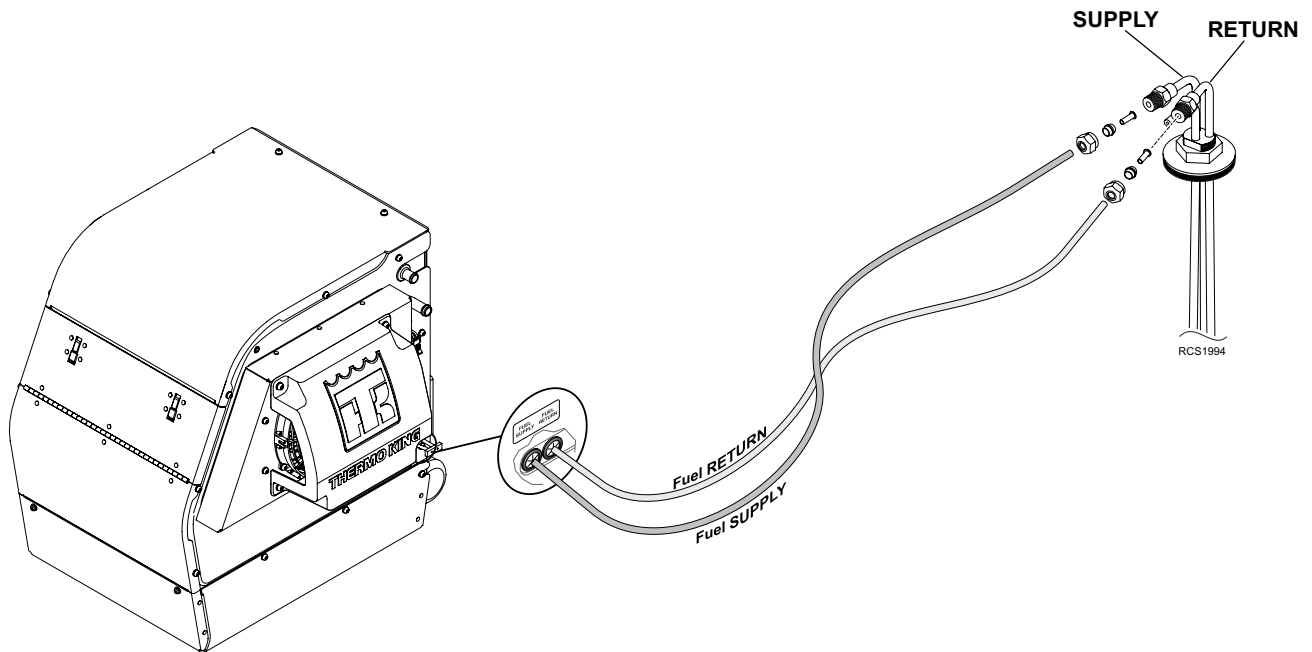

Tractor Coolant Hose Installation

Preferred Installation – APU Coolant Hoses Tee’d Directly Into Tractor’s Heater Hoses

Note: Skip this step if your APU has the Closed Loop Cooling Option.

Coolant Hose Routing and Connections

Note: If the Arctic Block Temperature Sensor Option is to be installed, it should be installed at this time.

Each coolant hose installation will be different. Carefully review the tractor’s engine cooling system to determine the best method for installing the cooling hoses and hand valves. Consult tractor dealer or OEM for assistance in identifying correct coolant hoses or engine fittings required for proper installation.

Note: All APU coolant hoses should be installed in such a way as to allow the hand valves to isolate the APU cooling system from the tractor’s cooling system. This hand valve must be located as close to the tractor’s engine as possible.

Theory of Operation

With the tractor’s engine shut off, and the TriPac APU engine operating, warm coolant is circulated from the APU engine up to the tractor’s engine and then back to the APU engine. This keeps the tractor’s engine warm allowing for easier cold starts.

- When the TriPac APU engine is running and coolant temperature reaches normal operating temperature of 180 F (82 C), the thermostat will open allowing hot coolant to flow from the APU **OUTLET** fitting forward to the tractor’s engine.
- Hot coolant enters the tractor’s engine block through an **INLET** fitting typically located near the water pump.
- Hot coolant circulates through the tractor’s engine block and exits an **OUTLET** fitting typically used for the heater.
- Warm coolant then returns to the TriPac APU and enters the **INLET** fitting.
- Warm coolant circulates through the APU’s engine block to absorb heat before being pumped back out to the tractor’s engine.
- Hand valves are installed to allow the APU’s cooling system to be isolated from the tractor’s cooling system to allow for component servicing.

Installation Procedures

Special Tools Required
Utility Knife
Pipe Thread Sealer

1. Drain coolant from tractor’s radiator and engine. Keep for re-use.
2. Locate **HEATER INLET** coolant hose on tractor’s engine:
 - a. Cut tractor’s heater inlet hose and install pipe fittings, elbow, tee fitting and hand valve.
 - b. From the hand valve, connect and route a new coolant hose back to the **OUTLET** fitting located on the APU.
 - c. **CLOSE** hand valve.
3. Locate **HEATER OUTLET** coolant hose on the tractor’s engine:
 - a. Cut tractor’s heater outlet hose and install pipe fittings, elbow, tee fitting and hand valve.
 - b. From shutoff valve, connect and route a new coolant hose back to the **INLET** fitting located on the APU pre-cooler.
 - c. **OPEN** hand valve.
4. Install protective plastic sleeving on all coolant hoses and secure coolant hoses with clamps.
5. Make sure the APU **OUTLET** hand valve (tractor inlet, next to water pump) is **closed**. If this valve is left open, coolant will be sitting on top of the TriPac thermostat and not allow the TriPac engine to bleed air.

Note: The system will be bled of air later by following the “A/C System Charging and APU Engine Start-up Procedures”.

- a. Add coolant removed earlier back into the tractor’s radiator.
 - b. **DO NOT** start the tractor’s engine at this time.
6. Install supplied coolant nameplate in a visible area near the tractor’s coolant fill cap.

Figure 28. APU Coolant Hoses Tee'd Directly Into Tractor's Heater Hoses Shown

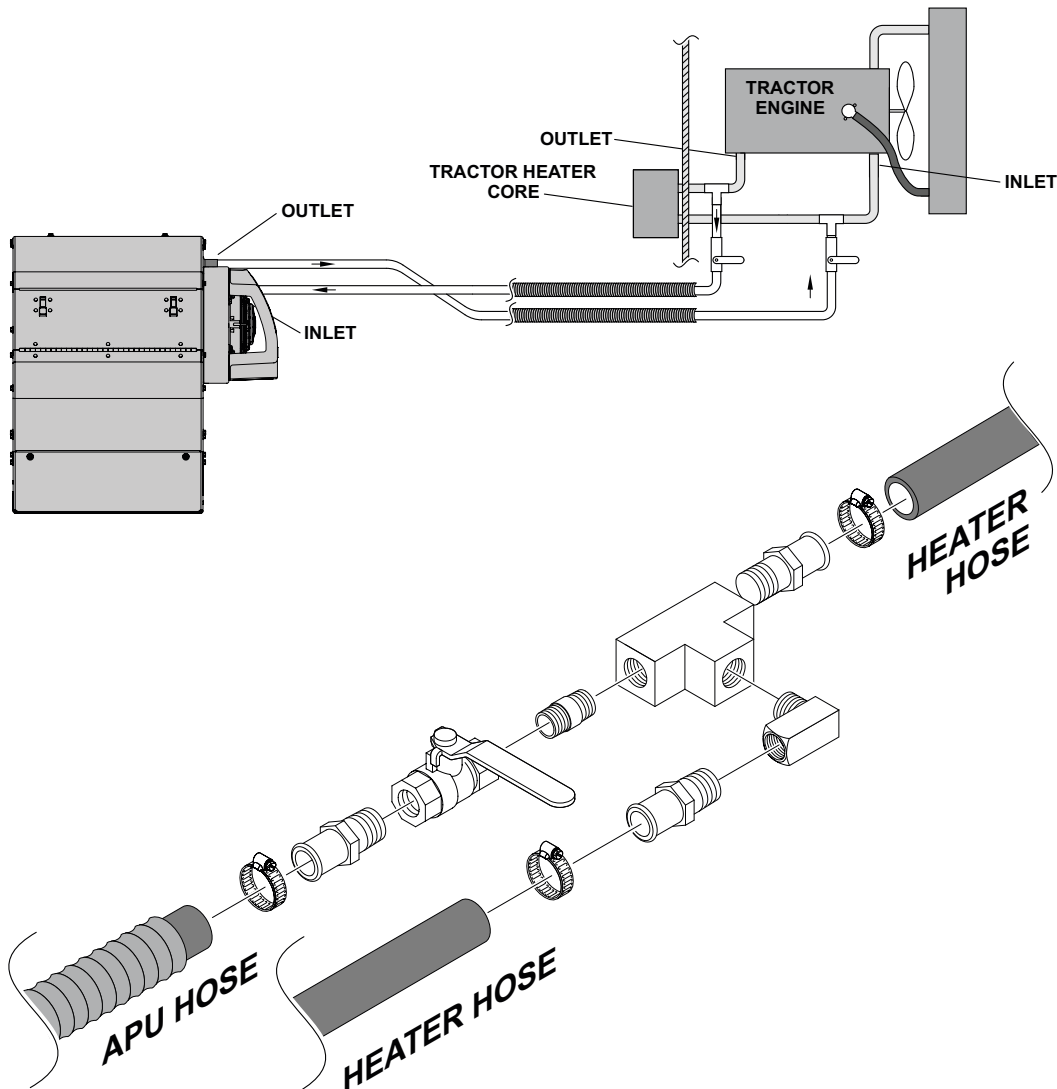

ABA715-1

6

NOTICE

This truck is equipped with auxiliary power unit. Coolant system must be bled after main engine coolant system servicing.



Alternative Installation – APU Coolant Hoses Attached Directly To Fittings On Tractor’s Engine

Note: Skip this step if your APU has the Closed Loop Cooling Option.

Coolant Hose Routing and Connections

Note: If the Arctic Block Temperature Sensor Option is to be installed, it should be installed at this time.

Each coolant hose installation will be different. Carefully review the tractor’s engine cooling system to determine the best method for installing the cooling hoses and hand valves. Consult tractor dealer or OEM for assistance in identifying correct coolant hoses or engine fittings required for proper installation.

Note: All APU coolant hoses should be installed in such a way as to allow the hand valves to isolate the APU cooling system from the tractor’s cooling system. This hand valve must be located as close to the tractor’s engine as possible.

Theory of Operation

With the tractor’s engine shut off, and the TriPac APU engine operating, warm coolant is circulated from the APU engine up to the tractor’s engine and then back to the APU engine. This keeps the tractor’s engine warm allowing for easier cold starts.

- When the TriPac APU engine is running and coolant temperature reaches normal operating temperature of 180 F (82 C), the thermostat will open allowing hot coolant to flow from the APU **OUTLET** fitting forward to the tractor’s engine.
- Hot coolant enters the tractor’s engine block through an **INLET** fitting typically located near the water pump.
- Hot coolant circulates through the tractor’s engine block and exits an **OUTLET** fitting typically used for the heater.
- Warm coolant then returns to the TriPac APU and enters the **INLET** fitting.
- Warm coolant circulates through the APU’s engine block to absorb heat before being pumped back out to the tractor’s engine.
- Hand valves are installed to allow the APU’s cooling system to be isolated from the tractor’s cooling system to allow for component servicing.

Installation Procedures

Special Tools Required
Utility Knife
Pipe Thread Sealer

1. Drain coolant from tractor’s radiator and engine. Keep for re-use.
2. Use the tractor’s heater hoses as a guide to locate an **INLET** plug on the engine before the water pump. Remove plug and:
 - a. Install hose fittings, short section of coolant hose and hand valve.
 - b. From the hand valve, install a hose fitting and route a new coolant hose back to the **OUTLET** fitting located on the APU.
 - c. **CLOSE** hand valve.
3. Use the tractor’s heater hoses as a guide to locate an **OUTLET** plug on the engine block. Remove plug and:
 - a. Install hose fittings, short section of coolant hose and hand valve.
 - b. From the hand valve, install a hose fitting and route a new coolant hose back to the **INLET** fitting located on the APU pre-cooler.
 - c. **OPEN** hand valve.
4. Install protective plastic sleeving on all coolant hoses and secure coolant hoses with clamps.
5. Make sure the APU **OUTLET** hand valve (tractor inlet, next to water pump) is **closed**. If this valve is left open, coolant will be sitting on top of the TriPac thermostat and not allow the TriPac engine to bleed air.

Note: The system will be bled of air later by following the “A/C System Charging and APU Engine Start-up Procedures”.

- a. Add coolant removed earlier back into the tractor’s radiator.
 - b. **DO NOT** start the tractor’s engine at this time.
6. Install supplied coolant nameplate in a visible area near the tractor’s coolant fill cap.

Figure 29. APU Coolant Hoses Attached Directly To Fittings On Tractor’s Engine Shown

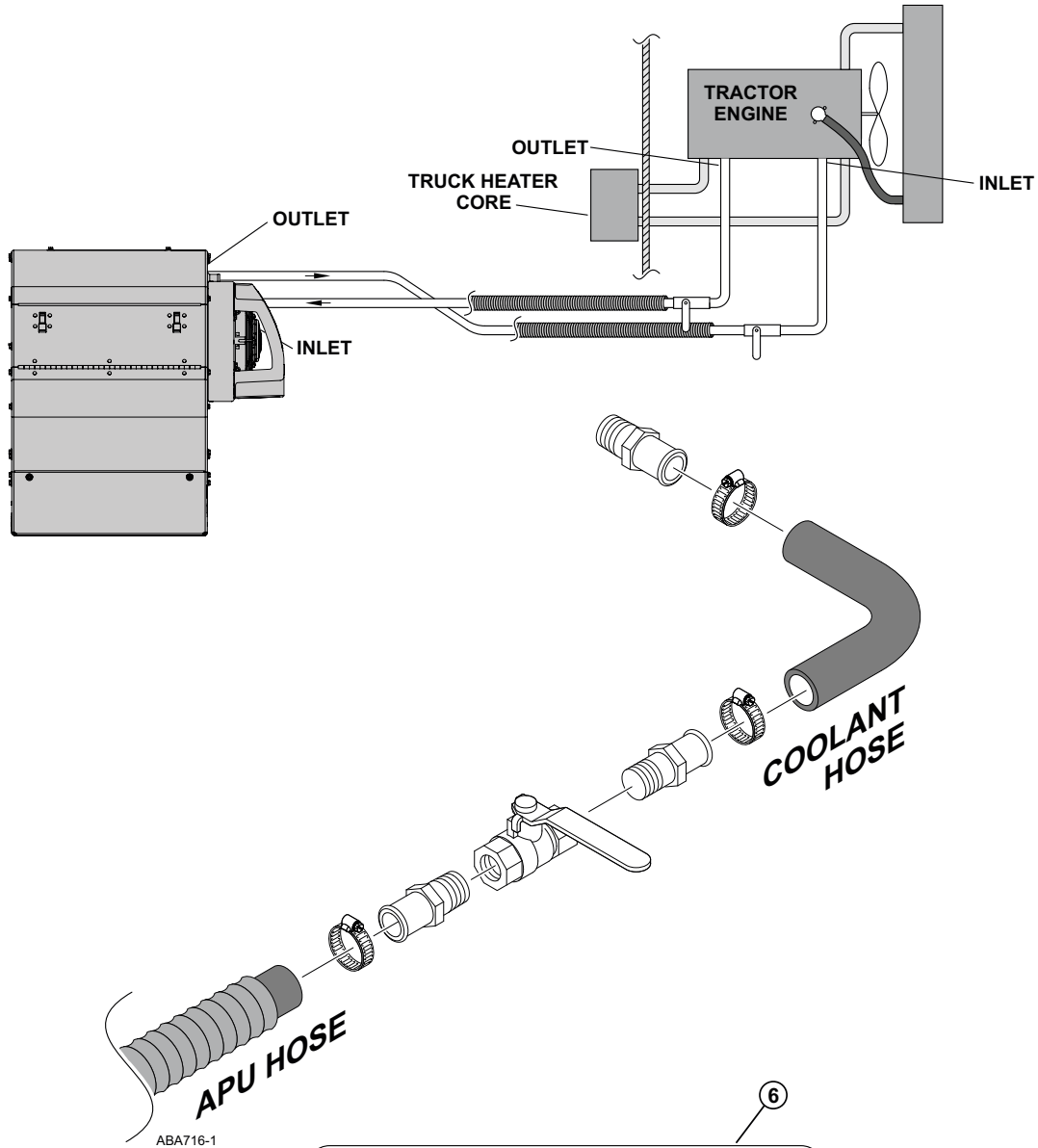

6

NOTICE

This truck is equipped with auxiliary power unit. Coolant system must be bled after main engine coolant system servicing.

Arctic Switch (Option)

Installation Procedures

⚠ Caution

Risk of Injury!

Always wear safety goggles and work gloves when working with antifreeze. The APU and tractor's engine coolant system should be at ambient temperature to prevent hot, pressurized coolant from causing painful burns to exposed skin and eyes.

⚠ Caution

Risk of Injury!

To prevent the APU from starting unexpectedly, set all electrical controls to the OFF position BEFORE connecting wires to battery.

1. Locate Arctic Option harness (**WT2, WT2-RTN**) band wrapped inside unit, near top, right side of frame. Un-band and route harness and connector out of unit, through hole in right side of frame, behind pre-cooler coil. Secure connector to anchor provided on outside of panel as shown in illustration.
2. Locate **INLET** coolant hose and measure approximately 6.00 in. (152.4 mm) out from APU.
3. Slide sleeving away to expose coolant hose and mark 3.00 in. (76.2 mm) to be removed.
4. Clamp off each side of coolant hose with a hose crimper to prevent excessive coolant loss.
5. Use a hose cutter and remove 3.00 in. (76.2 mm) section of coolant hose.
6. Install tube and sensor assembly with hose clamps.

Important: When tube and sensor assembly is installed horizontally sensor must face down, when installed vertically sensor must face towards APU (**DETAIL A**).

7. Plug sensor harness to mating 2-pin connector (**WT2, WT2-RTN**) located outside APU.
8. Provide a drip loop and secure all wires adequately with supplied band wraps.
9. Operate unit, check for leaks and reinstall sleeving on coolant hose.

Figure 30. Arctic Switch Installation Shown

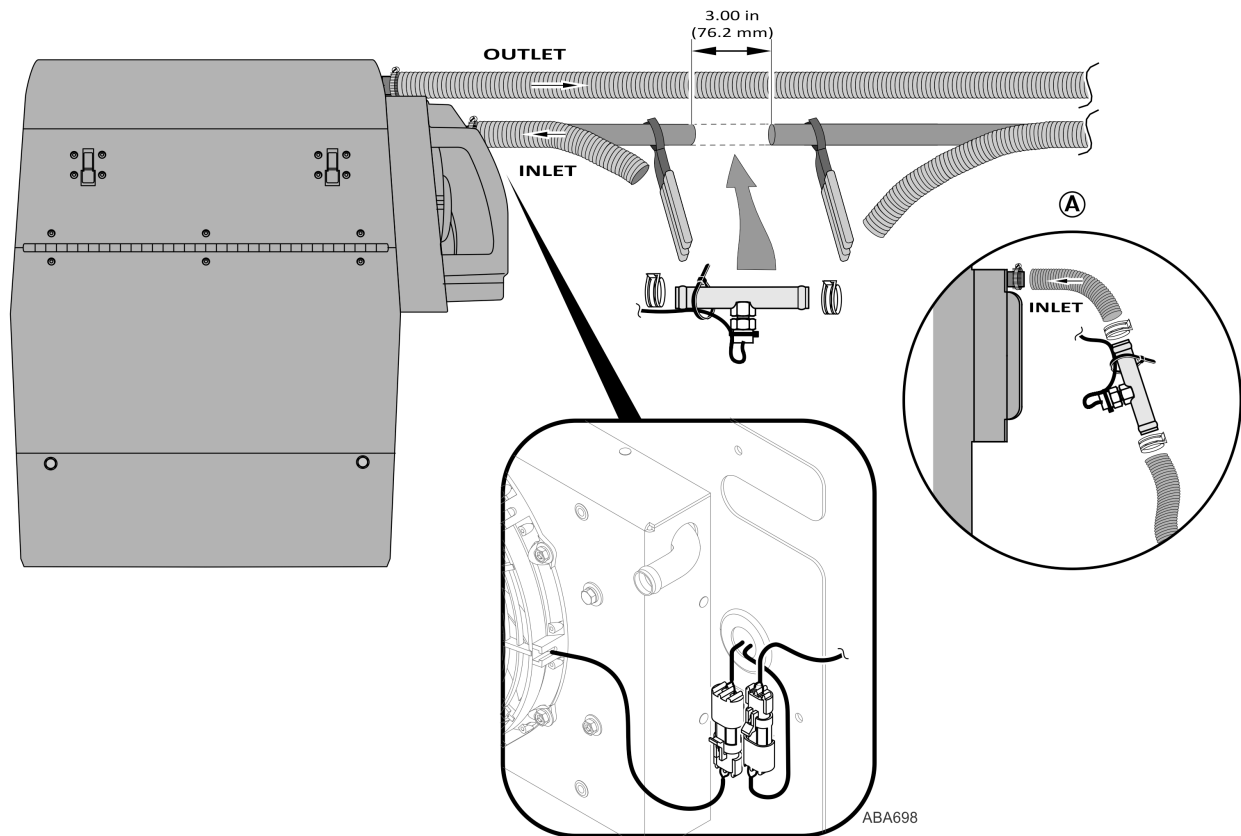

Priming The Heater Fuel System (Heat Option)

Important: *It is important the heater fuel system be primed before attempting to operate the heater for the first time. Failure to prime the pump will cause the unit to shutdown, set diagnostic codes and cause damage to the fuel pump.*

There are four (4) options for priming the TriPac 3 Espar heater fuel pump.

- **Option 1, Modify Heater Priming Harness 2041144:** The priming harness 2041144 heater is specific to the Espar AX1, AX2, D2 and D4 series heaters paired with the TriPac EVOLUTION. Heater priming harness 2041144 must be modified to work with the TriPac 3 Series of Espar AS2 D2L /AS2 D4L, AS3 D2L, AM3 D4L heaters.
- **Option 2, Use Heater Priming Harness 2041144 and Jumper Harness 2043233:** The priming harness 2041144 heater is specific to the Espar AX1, AX2, D2 and D4 series heaters paired with the TriPac EVOLUTION. Heater priming harness 2041144 and jumper Harness 2043233 can be used together to prime the TriPac 3 Espar AS2 D2L /AS2 D4L, AS3 D2L, AM3 D4L heater fuel system.
- **Option 3, Use the TriPac 3 / Evolution Heater Priming Harness 2043232:** Heater Priming Harness 2043232 will work to prime both the new TriPac 3 and TriPac Evolution series of Espar heater fuel pumps without modification or jumpers. It has a “Y” connection to fit both style fuel pumps.
- **Option 4, Use the Air Heater EasyScan Diagnostic Tool Part Number 2043228:** Thermo King offers the Air Heater EasyScan Diagnostic Tool: Part Number 2043228. The EasyScan diagnostic tool supports all ESPAR heaters and control units, providing evaluation of the current operating states, function tests, and fault analyses on devices and components. The Air Heater EasyScan Diagnostic Tool 2043228 is capable of priming the TriPac 3 heater fuel system.

OPTION 1: Priming Heater Fuel Pump (Modify Heater Priming Harness 2041144)

Important: It is important the heater fuel pump be primed before attempting to operate the heater for the first time. Failure to prime the pump will cause the unit to shutdown, set diagnostic codes and cause damage to the fuel pump.

Special Tools Required
Heater Priming Harness (2041144)

Important: Heater Priming Harness 2041144 is specific to the Espar AX1, AX2, D2 and D4 series heater paired with the TriPac EVOLUTION. For use with the TriPac 3 Espar heaters AS2 D2L, AM2 D4L, AS3 D2L, and AM3 D4L, the harness 2041144 fuel pump connector must be modified with these fuel pump connector parts:

- A) Qty. 2 of terminal PN 1452668-1 (MCON RECEPTACLE AWG 20-18(S) – TYCO)
- B) Qty. 1 of connector PN 872-857-561 (2-PIN CONNECTOR-TYCO)
- C) Qty. 2 of seal PN 967067 (WIRE SEAL – TYCO)

Figure 31. Heater Fuel Pump Priming Harness Connections - Harness 2041144 Modification

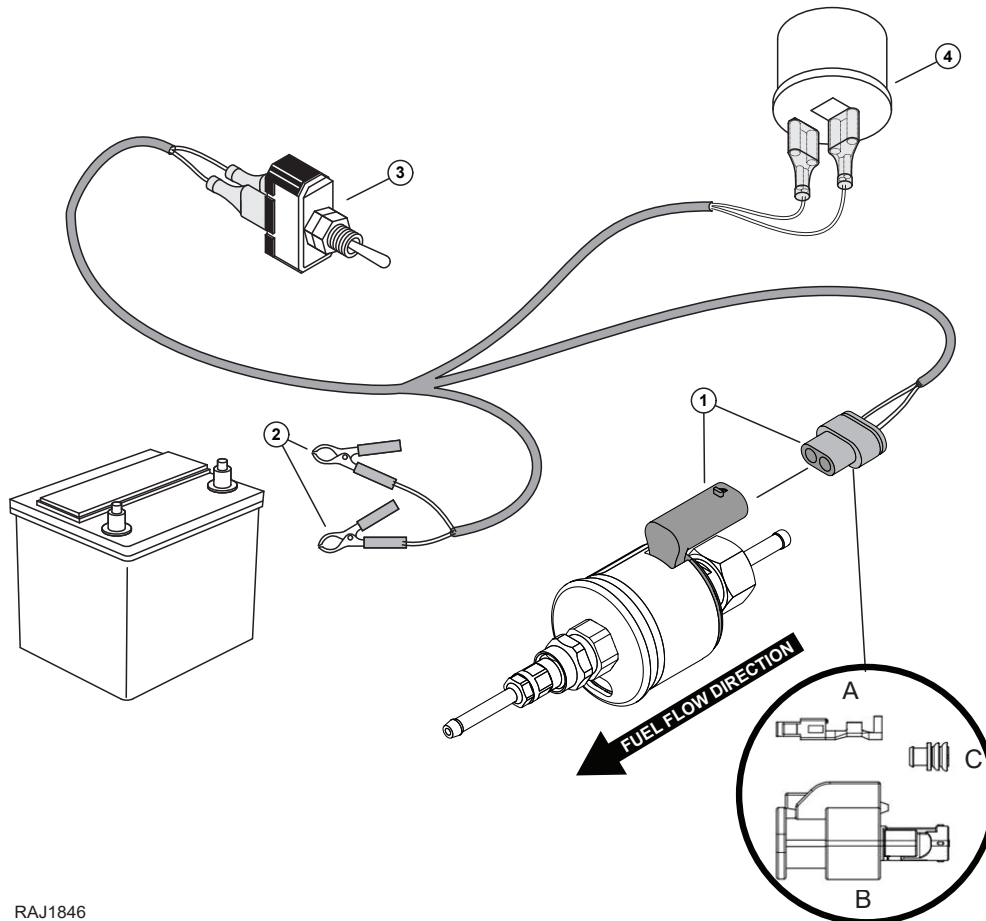

RAJ1846

Note: Verify there is a sufficient amount of fuel in the fuel tank before beginning the priming procedures.

The heater uses a pulse style fuel pump. You must use the heater priming harness to operate the fuel pump to prime the system. Applying continuous power to the pump will not work

1. Attach **Heater Priming Harness** connector to heater fuel pump.
2. Attach alligator clips to the battery:



Priming The Heater Fuel System (Heat Option)

- RED to(+) Positive Battery Connection
 - BLACK to(-) Negative Battery Connection
3. Turn priming harness switch to the “ON” position.
 4. Flasher unit will operate the fuel pump (ON/OFF/ON/OFF) to prime the system.
 5. Allow system to operate for approximately 5 minutes to bleed air from the fuel lines.
Note: Running the fuel pump longer than 5 minutes will cause the heater to emit excessive white smoke when operated.
 6. Check fuel lines and system for leaks.
 7. Turn priming harness switch to the “OFF” position. Disconnect positive and then negative battery connections.
 8. Disconnect priming harness connector from heater fuel pump.
 9. Attach heater fuel pump harness onto heater fuel pump.

OPTION 2: Priming Heater Fuel Pump (Harness 2041144 and Jumper Harness 2043233)

Important: It is important the heater fuel pump be primed before attempting to operate the heater for the first time. Failure to prime the pump will cause the unit to shutdown, set diagnostic codes and cause damage to the fuel pump.

Special Tools Required
Heater Priming Harness 2041144
Heater Priming Harness Jumper 2043233

Important: Heater Priming Harness 2041144 is specific to the Espar AX1, AX2, D2 and D4 series heater paired with the TriPac EVOLUTION. To use this harness with the TriPac 3 Espar heaters AS2 D2L, AM2 D4L, AS3 D2L, and AM3 D4L, the Heater Priming Harness Jumper 2043233 must also be used.

Figure 32. Heater Fuel Pump Priming Harness Connections - Heater Priming Harness 2041144 + Jumper 2043233

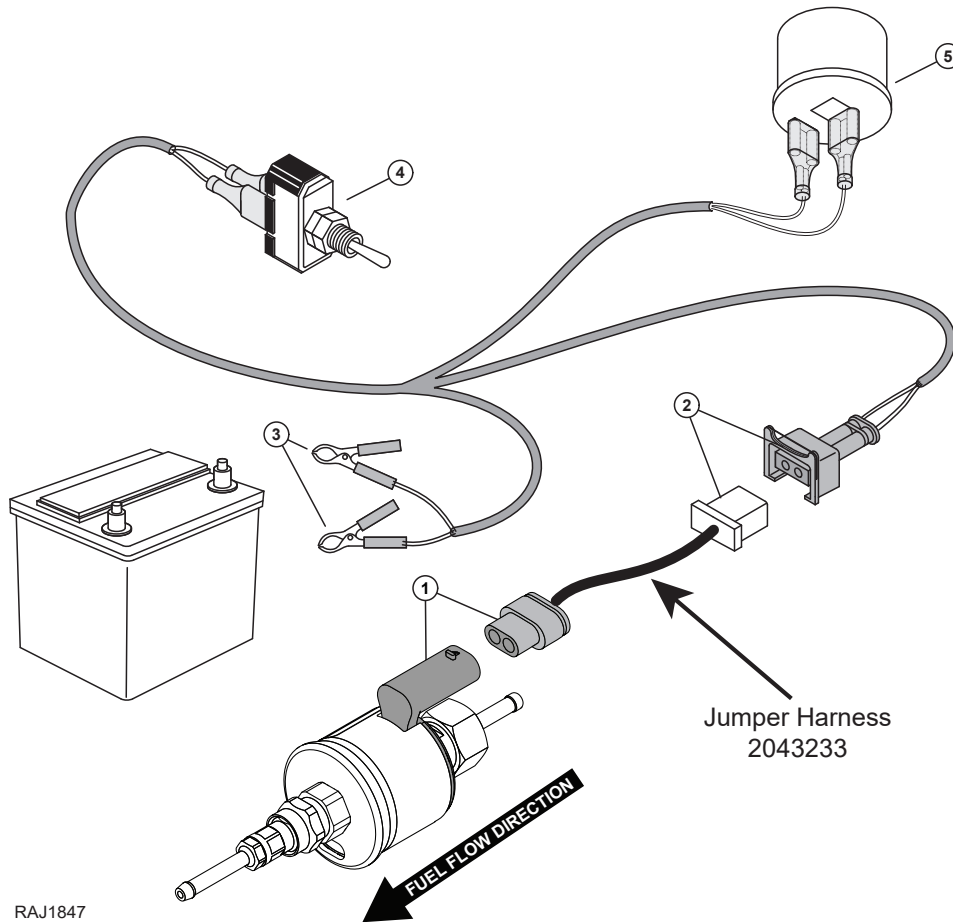

RAJ1847

Note: Verify there is a sufficient amount of fuel in the fuel tank before beginning the priming procedures.

The heater uses a pulse style fuel pump. You must use the heater priming harness to operate the fuel pump to prime the system. Applying continuous power to the pump will not work

1. Attach **Heater Priming Jumper Harness 2043233** connector to heater fuel pump.
2. Attach **Heater Priming Harness 2041144** to **Jumper Harness 2043233** connector.
3. Attach alligator clips to the battery:
 - **RED to (+) Positive Battery Connection**



Priming The Heater Fuel System (Heat Option)

- **BLACK to(-) Negative Battery Connection**

4. Turn priming harness switch to the “ON” position.
5. Flasher unit will operate the fuel pump (ON/OFF/ON/OFF) to prime the system.
6. Allow system to operate for approximately 5 minutes to bleed air from the fuel lines.

Note: Running the fuel pump longer than 5 minutes will cause the heater to emit excessive white smoke when operated.

7. Check fuel lines and system for leaks.
8. Turn priming harness switch to the “OFF” position. Disconnect positive and then negative battery connections.
9. Disconnect priming harness / jumper harness connector from heater fuel pump.
10. Attach heater fuel pump harness onto heater fuel pump.

OPTION 3: Priming Heater Fuel Pump (Priming Harness 2043232)

Important: It is important the heater fuel pump be primed before attempting to operate the heater for the first time. Failure to prime the pump will cause the unit to shutdown, set diagnostic codes and cause damage to the fuel pump.

Special Tools Required
Heater Priming Harness 2043232

Important: Heater Priming Harness 2043232 will work to prime both the new TriPac 3 and TriPac Evolution series of Espar heater fuel pumps without modification or jumpers. It has a "Y" connection to fit both style fuel pumps.

Figure 33. Heater Fuel Pump Priming Harness Connections – Heater Priming Harness 2043232

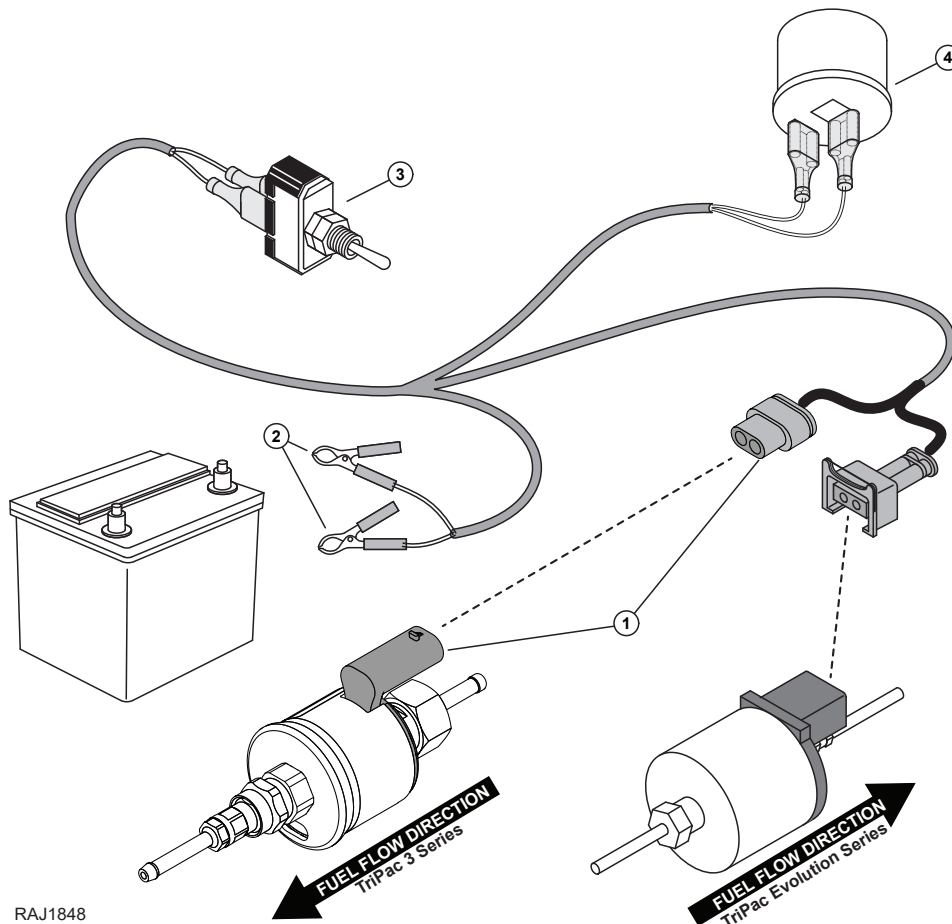

RAJ1848

Note: Verify there is a sufficient amount of fuel in the fuel tank before beginning the priming procedures.

The heater uses a pulse style fuel pump. You must use the heater priming harness to operate the fuel pump to prime the system. Applying continuous power to the pump will not work

1. Attach **Heater Priming Jumper Harness 2043232** connector to heater fuel pump.
2. Attach alligator clips to the battery:
 - **RED to (+) Positive Battery Connection**
 - **BLACK to (-) Negative Battery Connection**
3. Turn priming harness switch to the "ON" position.
4. Flasher unit will operate the fuel pump (ON/OFF/ON/OFF) to prime the system.



THERMO KING

Priming The Heater Fuel System (Heat Option)

5. Allow system to operate for approximately 5 minutes to bleed air from the fuel lines.

Note: Running the fuel pump longer than 5 minutes will cause the heater to emit excessive white smoke when operated.

6. Check fuel lines and system for leaks.

7. Turn priming harness switch to the "OFF" position. Disconnect positive and then negative battery connections.

8. Disconnect priming harness connector from heater fuel pump.

9. Attach heater fuel pump harness onto heater fuel pump.

OPTION 4: Priming Heater Fuel Pump (EasyScan Tool 2043228)

Important: *It is important the heater fuel pump be primed before attempting to operate the heater for the first time. Failure to prime the pump will cause the unit to shutdown, set diagnostic codes and cause damage to the fuel pump.*

Special Tools Required
Air Heater EasyScan Diagnostic Tool 2043228

Important: *The Air Heater EasyScan Diagnostic Tool 2043228 is capable of priming the heater fuel system. This procedure (H33A) can also be found in the TriPac 3 Diagnostic Manual 57116-19-OD.*

Note: *Verify there is a sufficient amount of fuel in the fuel tank before beginning the priming procedures.*

The heater uses a pulse style fuel pump. You must use the heater priming harness to operate the fuel pump to prime the system. Applying continuous power to the pump will not work



Priming The Heater Fuel System (Heat Option)

H33A – Air Heater Fuel Priming

Purpose:

To prime the air heater fuel line.

Materials Required:

- EasyScan Diagnostic Unit with supplied cables.
- EasyScan Diagnostic Program installed on a computer.

Procedure

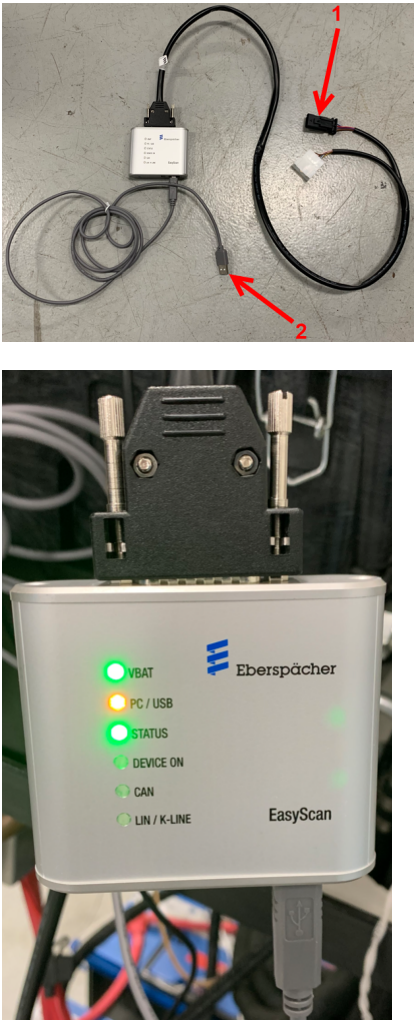
Step	Action	Result	Comments
1	Connect EasyScan Diagnostic Unit to Air Heater connector (1) and computer (2). Once connected properly, display lights will illuminate.		VBAT = Correctly connected to Air Heater STATUS = Blinking Green CAN = Blue when Diagnostics is selected
2	Open EasyScan on a computer.		

Step	Action	Result	Comments
3	Choose Select on the left side of the EasyScan screen and expand product offerings until AX2 or AX3 are shown. Check the box next to the appropriate product for your application.		
4	Choose Diagnostics on the left side of the EasyScan screen.	The CAN light on the EasyScan Diagnostic Unit will illuminate (blue). The Identification data screen will display.	
5	Choose the Components tab.		

Priming The Heater Fuel System (Heat Option)

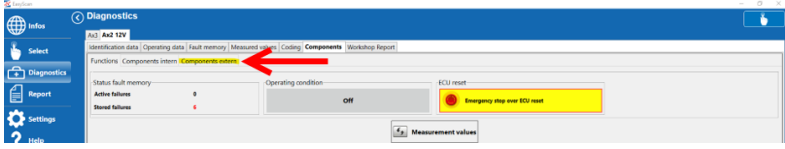
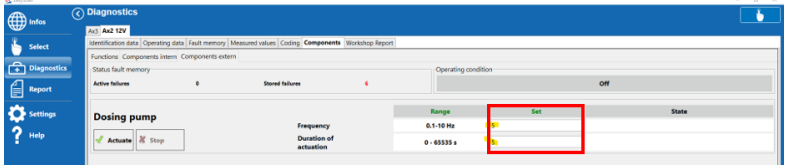
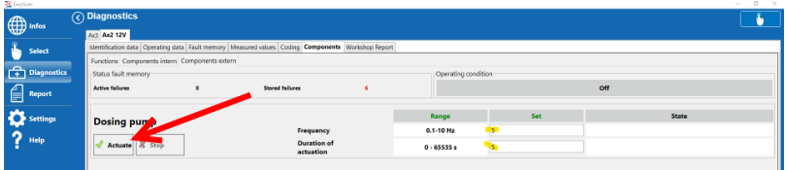
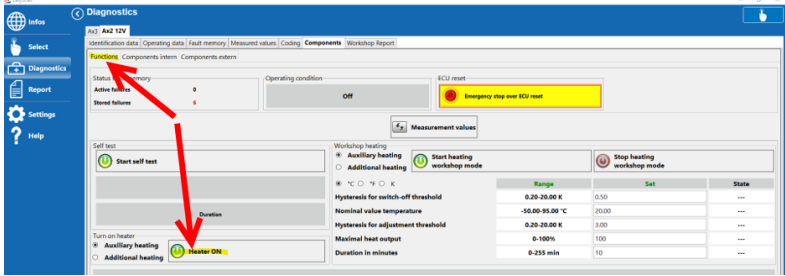
Step	Action	Result	Comments
6	Choose Components extern.		
7	<p>Enter a Frequency.</p> <ul style="list-style-type: none"> Thermo King recommends a medium range of pump frequencies between 3 and 5 Hz. This is a typical operation range for the pump when the heater is in service. Any number between .1 and 10 can be chosen, with higher numbers pumping fuel faster. <p>Enter Duration of actuation.</p> <ul style="list-style-type: none"> Thermo King recommends short intervals to prevent excess raw fuel being pumped into the combustion chamber. Use five second intervals, and watch the fuel being advanced until it enters the heater body. This is enough to prime the line and allow the heater to start via its own pre-start priming sequence. 		
8	With values set in step 7, click Actuate at bottom left corner of the screen.		It is recommended to have short durations and to position yourself to observe fuel moving through the fuel line.
<div style="border: 1px solid black; padding: 5px; text-align: center;"> <p>Notice</p> <p>Equipment Damage!</p> <p>Do not pump excess raw fuel into the chamber, this can result in damage to the heater.</p> </div>			
9	When the system is primed, the heater can be activated using EasyScan or using the In-Cab HMI by putting the system into heat mode and selecting a temperature above the current cab temperature.	<p>If using EasyScan, choose Functions > Heater ON.</p> 	

ConnectedSuite (Option)

Installation Best Practices

NOTE:
Record the serial number of TKV5 module before installing the module onto the truck.
The serial number will be used later to complete the activation procedures.

The following best practices should be followed to ensure a successful installation.

- For maximum signal strength the telematics module should be mounted as high as possible on rear exterior of cab/sleeper with an unobstructed line of sight towards the sky.
- Telematics module must be installed with harness connector facing down. NOT FACING UP OR SIDEWAYS.
- Seal all holes drilled into cab/sleeper with appropriate sealer.
- Secure telematics harness every 24.00 in. (609.6 mm) with insulated clamps. Clamps and fasteners are installer supplied.
- Do not overtighten any of the mounting hardware or damage to the components will result.

Note: To complete the installation, the ConnectedSuite software will need to be setup and programmed by an authorized Thermo King Dealer.

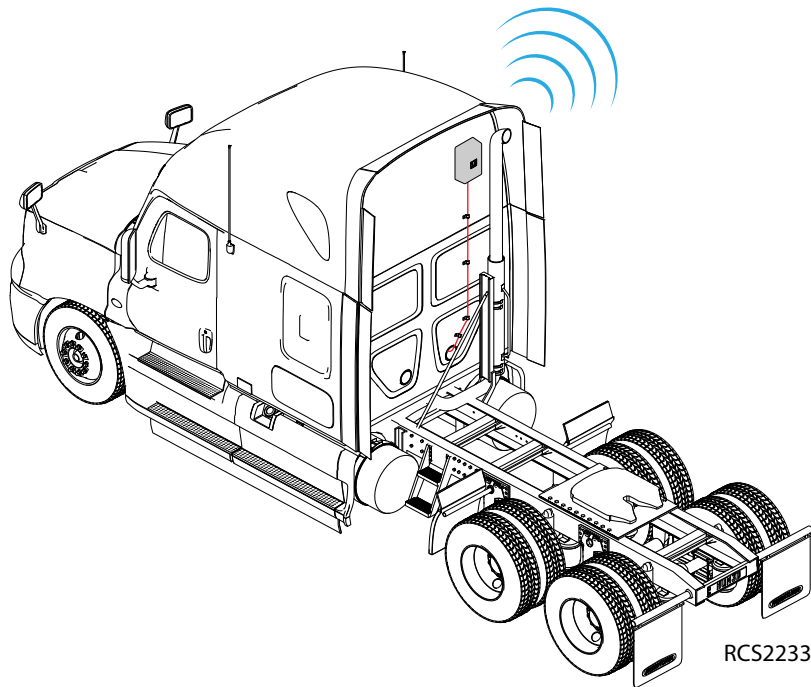

Installation Procedures

NOTE:
Record the serial number of TKV5 module before installing the module onto the truck.
The serial number will be used later to complete the activation procedures.

1. Preassemble the components:
 - a. Attach module to mounting base with four long M5 screws supplied and tighten to 3.4–4.9 Nm (30–44 in-lb).
 - b. Connect harness securely to module.
 - c. Insert cable tie mount into hole in mounting base and secure harness to base with cable tie.

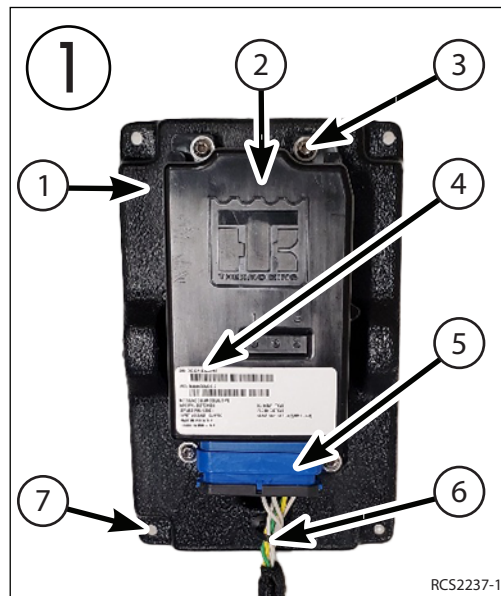

1.	Mounting Base	5.	Telematics Harness
2.	TKV5 Module	6.	Cable Tie
3.	Mounting Screws	7.	Truck mounting holes
4.	TKV5 Serial Number Location		

2. Install assembly onto truck with installer supplied fasteners.

Note: For maximum signal strength the telematics module should be mounted as high as possible on rear exterior of cab/sleeper with an unobstructed line of sight towards the sky.

- a. Install cover with two short M5 screws supplied and tighten to 3.4–4.9 Nm (30–44 in-lb).
 - b. Secure telematics harness every 24.00 in. (609.6 mm) with insulated clamps. Fasteners and clamps are installer supplied.
 - c. Route harness under cab, up through access hole, into bunk area.
3. Connect telematics harness as follows:
 - a. Remove existing **HMI** connector from the MAC and reconnect it to the mating **HMI** connector on the telematics harness.
 - b. Attach **HMI** connector to mating **HMI** connector on the MAC.
 - c. Attach **TELM** connector to mating **TELM** connector on the MAC.
 - d. **USB** connector does not get connected.
 - e. Neatly bundle and secure all excess harnesses.
 4. Proceed to the **ConnectedSuite Activation Procedures** on the next page.

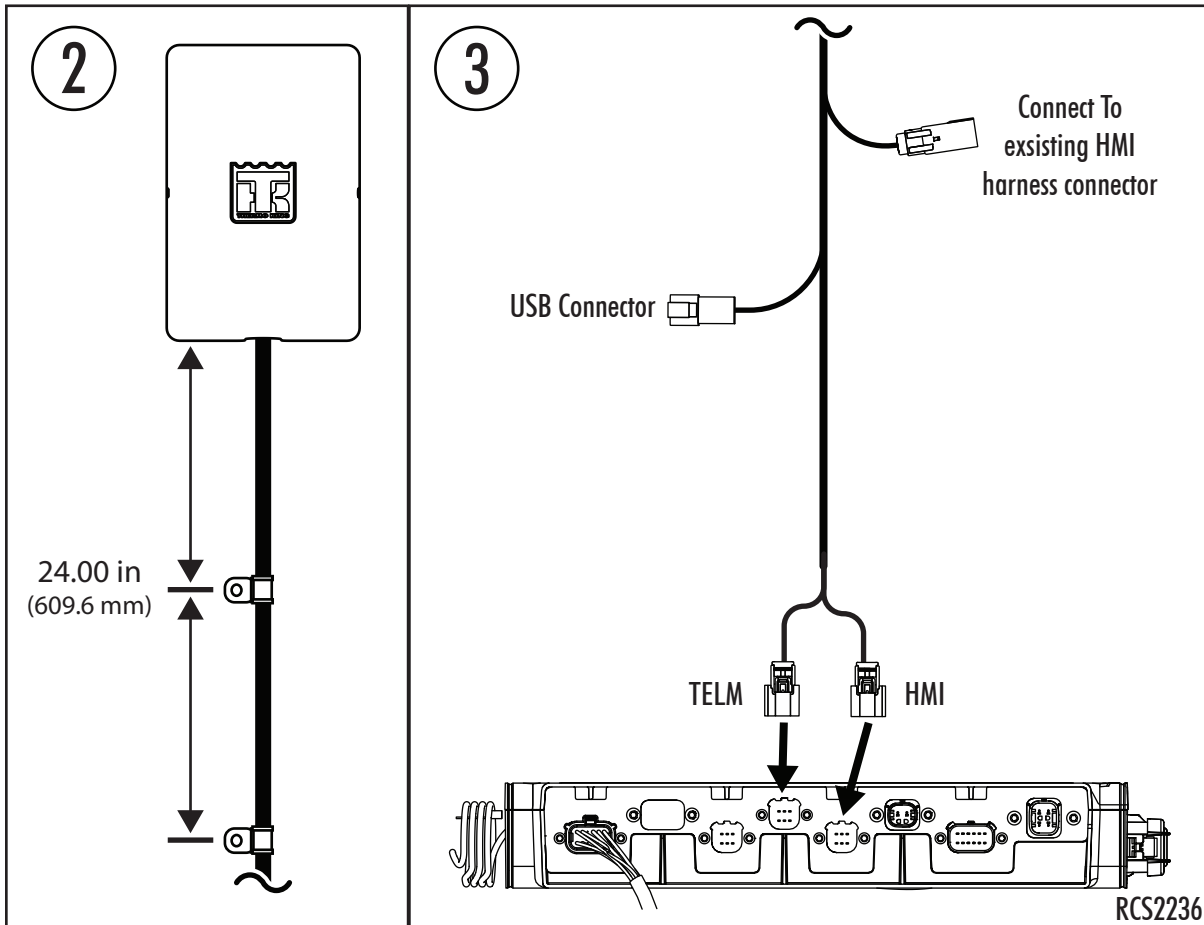



THERMO KING

ConnectedSuite (Option)

ConnectedSuite™ Activation Procedures

Customer Installations - Contact an authorized Thermo King Dealer to set up and activate the ConnectedSuite software.

Dealer Installations – Customer set up and activation process can be found [here](#).

Heater Start-Up Procedures

Note: See Operating and Diagnostic Manual TK 57116-19-OD for further diagnosis and service procedures if needed.

Note: Follow the instructions included in the EasyScan Kit to install, update, diagnose, and operate the heater.

Note: The EasyScan tool is not required for heater start-up. It can be used for diagnosing start-up issues.

Special Tools Required
Air Heater EasyScan Diagnostic Tool (Part Number 2043228)
Note: The EasyScan Diagnostic Tool (Part Number 2043228) is new for the TriPac 3 / AX2 and AX3 Espar Heaters. It is not required for heater start-up and can be used for diagnosing start-up issues.

Connecting Diagnostic Tool

1. Connect the 8-pin diagnostic connector to the mating connector located on the heater harness inside the sleeper near the heater.

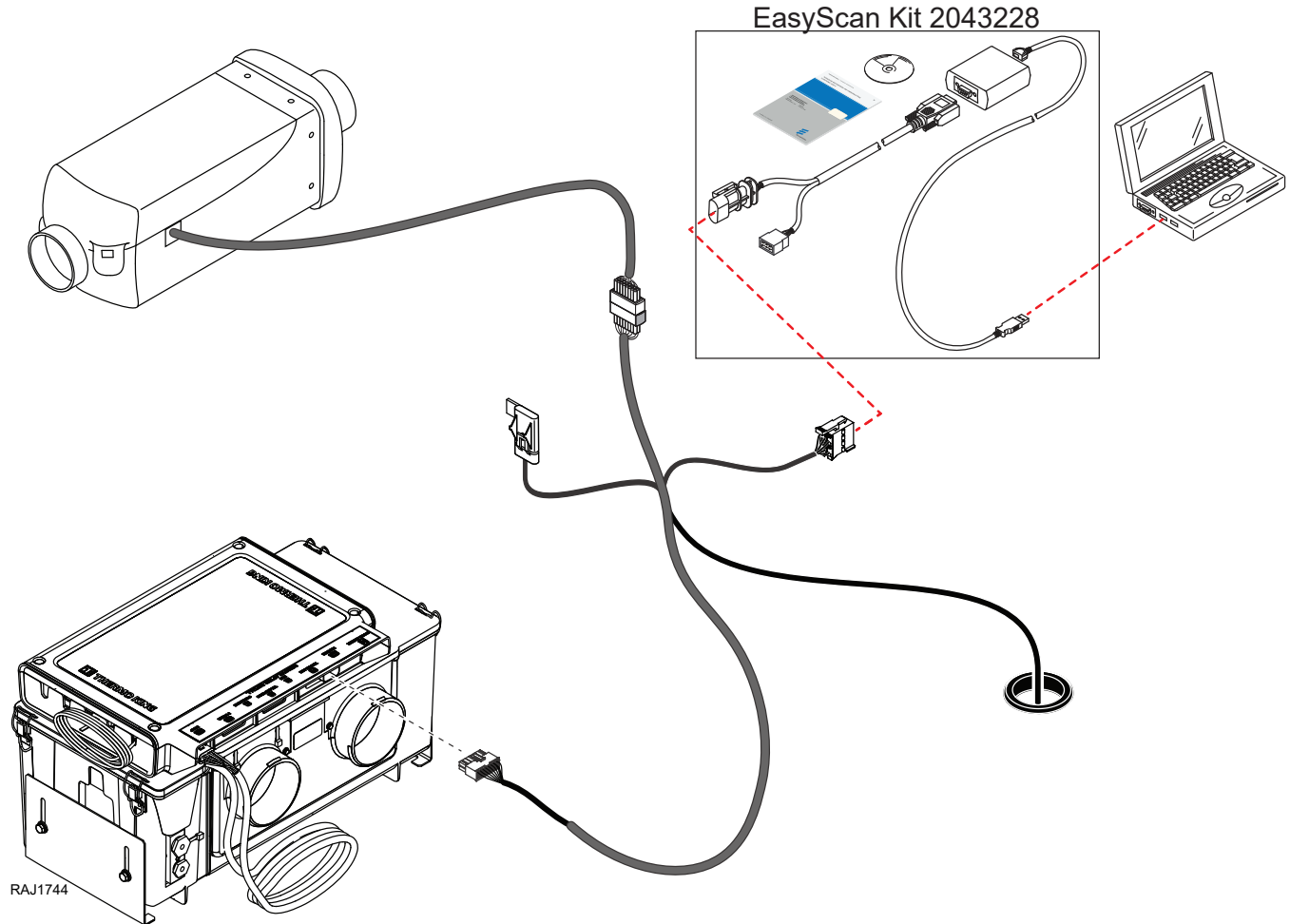

A/C System Charging and APU Engine Start-up Procedures

This is a multi-step procedure consisting of:

- a. adding a partial refrigerant charge to the system
- b. verifying APU engine has the proper amount of oil
- c. bleeding air from the APU cooling system
- d. bleeding air from the APU fuel lines
- e. running the APU with the A/C operating and adjusting the engine rpm's

Important: The engine RPM is not adjustable on TriPac 3 units equipped with the ATD exhaust system. The adjustment locations shown below have anti-tamper features.

Figure 34. Engine Speed Adjustment

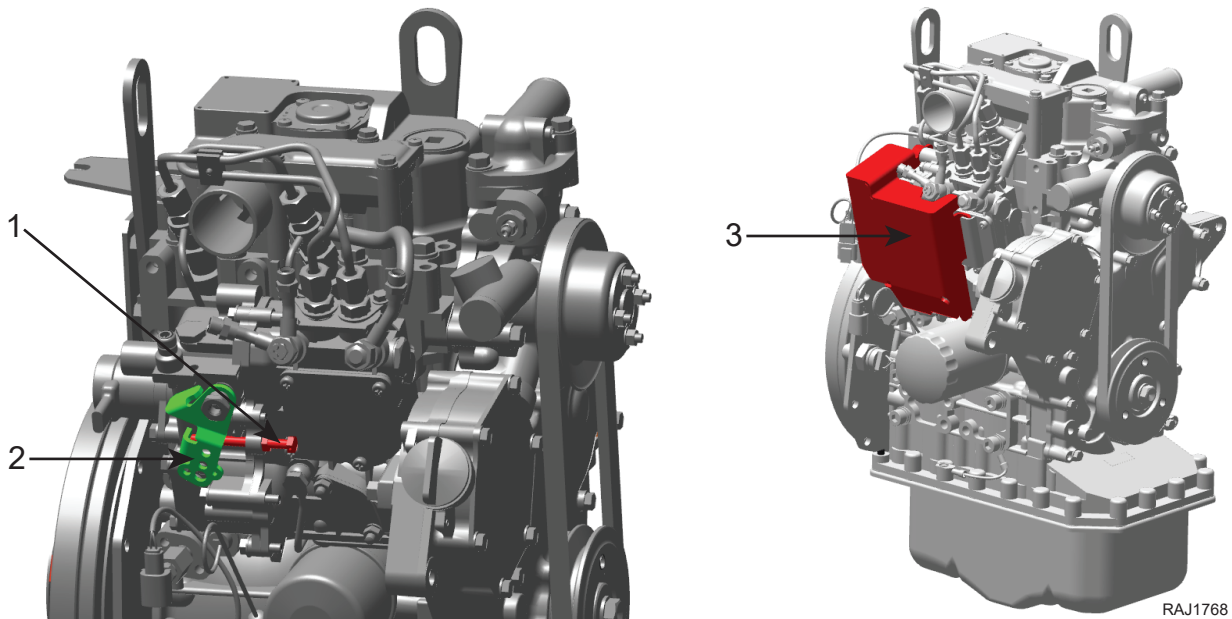

1.	Low Speed Limiting Bolt
2.	Governor Lever
3.	Anti-tamper Cover (ATD Units Only)

- f. system fluids leak check
- g. verifying alternator output voltage
- h. adding a full refrigerant charge to the system

Adding Refrigerant Charge

Important: Before starting the APU engine, oil and coolant levels must be checked to prevent damage to the engine and the A/C system must have a partial charge of refrigerant added to prevent damage to the A/C compressor. See "Bleeding the Coolant System" and "Bleeding the Fuel Lines" before adding a partial refrigerant charge.

Special Tools Required	
R134a Refrigerant	
Scale	

1. Connect refrigerant hoses to the unit's service fittings.
2. Connect refrigerant bottle to gauge manifold and place it on the scale.
3. Open refrigerant bottle valve for liquid and purge the charging line.
4. Keep the low pressure side valve of the gauge manifold closed. Open the high pressure side valve.
5. Add refrigerant until reaching 1 lb. 8 oz. of R-134a.
6. Close refrigerant bottle valve and the high side valve of the gauge manifold.

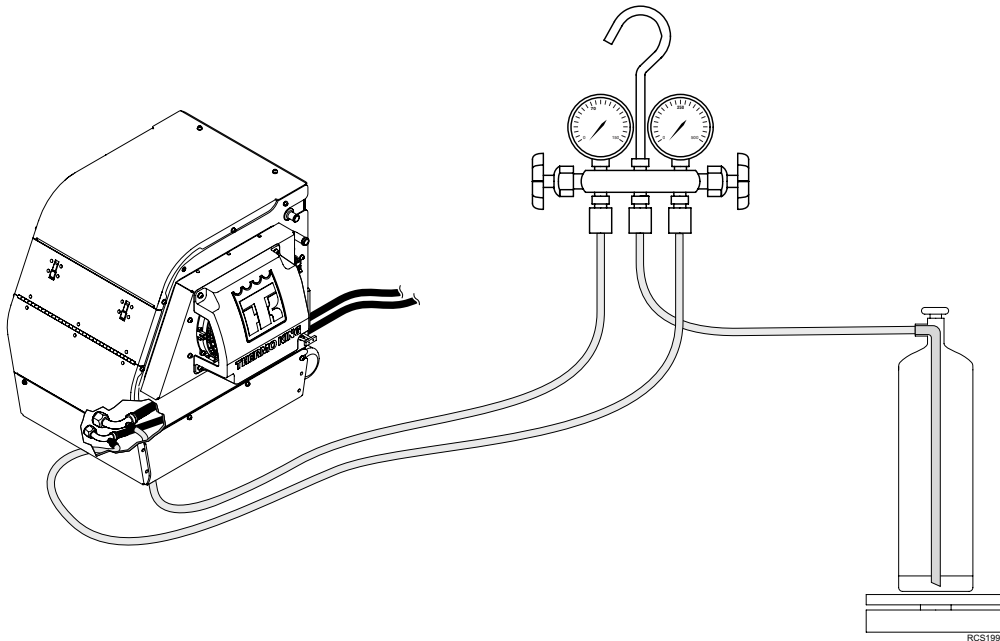

APU Engine Start-up Procedures

Important: To avoid damage to the APU engine and A/C compressor, verify the APU engine has proper amount of oil and the A/C system has a partial refrigerant charge **before** starting the engine.

Important: Units equipped with the Closed Loop Cooling Option only - Check sight glass on overflow tank to confirm coolant level before starting the APU's engine.

TriPac APU Oil Specifications	
Oil Capacity	4.5 qts. (including filter) 6.5 qts. Maximum
Oil Type	10W-30 for temperatures at or above -13 F (-25 C) 5W-30 for temperatures at or below -13 F (-25 C)

Bleeding the Standard Cooling System

Often when a TriPac unit cooling system is refilled, air is trapped in the engine block and/or under the thermostat. Use the following procedure to bleed air out of the block and the cooling system:

Note: If an engine runs with air trapped in the block, the engine may be damaged. Air in the block causes the high water temperature sensor reading to be inaccurate and delayed. This prevents the engine shutting down in time to prevent damage due to engine overheat.

Notice**Equipment Damage!**

Do not start the engine without bleeding the air out of the block.

1. Verify the TriPac OUTLET hand valve is CLOSED (tractor inlet, next to water pump). If this valve is left open, coolant will be sitting on top of the TriPac thermostat and not allow the TriPac engine to bleed air.
2. Open the TriPac INLET hand valve.
3. Install hose on bleed valve and place clean container underneath to catch any coolant.
4. Open bleed valve on the engine to allow air to bleed out.
5. When a steady stream of coolant flows from the bleed valve, tighten the bleed valve and remove the hose.

Figure 35. Coolant Bleed Valve Location On Water Pump

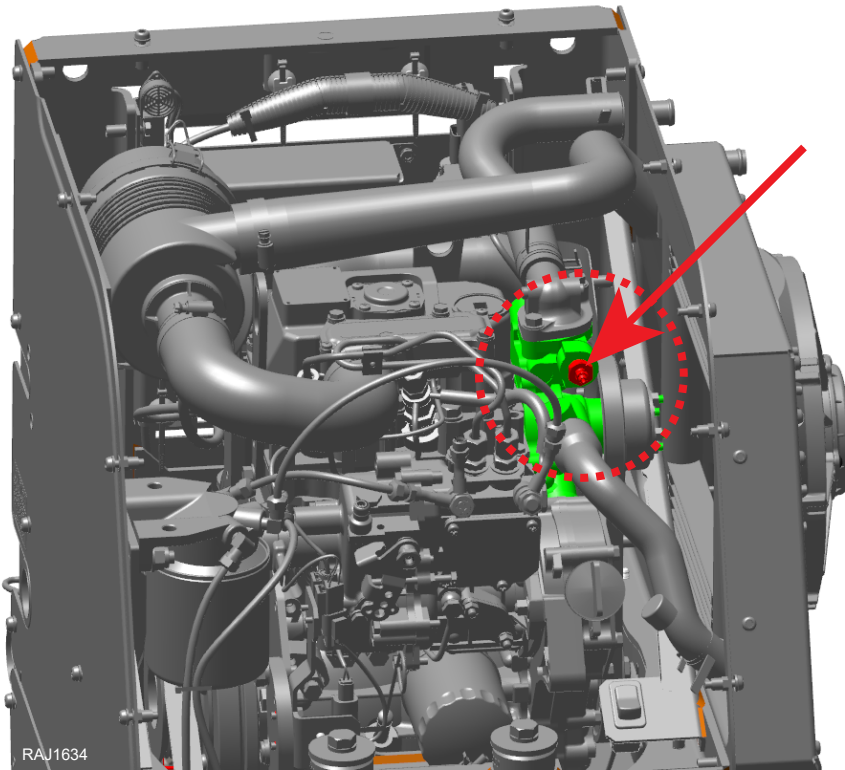

6. Open the TriPac OUTLET hand valve.
7. Replace drained coolant from the TriPac back into the truck's radiator.
8. Start the TriPac engine and use a non-contact thermometer pointed at the bleed valve area to monitor the coolant temperature.

Notice**Equipment Damage!**

Do not start the TriPac engine before a partial refrigerant charge has been added or damage to the A/C compressor will result.

9. When the temperature reaches 150 F (66 C), shut off the engine for 2 minutes to allow the thermostat to heat soak and open completely to purge air out of block, head, and water pump.
10. After 2 minutes, re-start the engine. The remaining air in the system will be forced to the truck radiator and the TriPac APU should now be bled of all air.
11. Properly dispose of any excess coolant according to local regulations.

Bleeding the Optional Closed Loop Cooling System

Often when a TriPac unit cooling system is refilled, air is trapped in the engine block and/or under the thermostat. Use the following procedure to bleed air out of the block and the cooling system:

Note: *If an engine runs with air trapped in the block, the engine may be damaged. Air in the block causes the high water temperature sensor reading to be inaccurate and delayed. This prevents the engine shutting down in time to prevent damage due to engine overheat.*

Notice

Equipment Damage!

Do not start the engine without bleeding the air out of the block.

1. Install hose on bleed valve and place clean container underneath to catch any coolant.
2. Open bleed valve on the engine to allow air to bleed out.

Figure 36. Coolant Bleed Valve Location On Water Pump

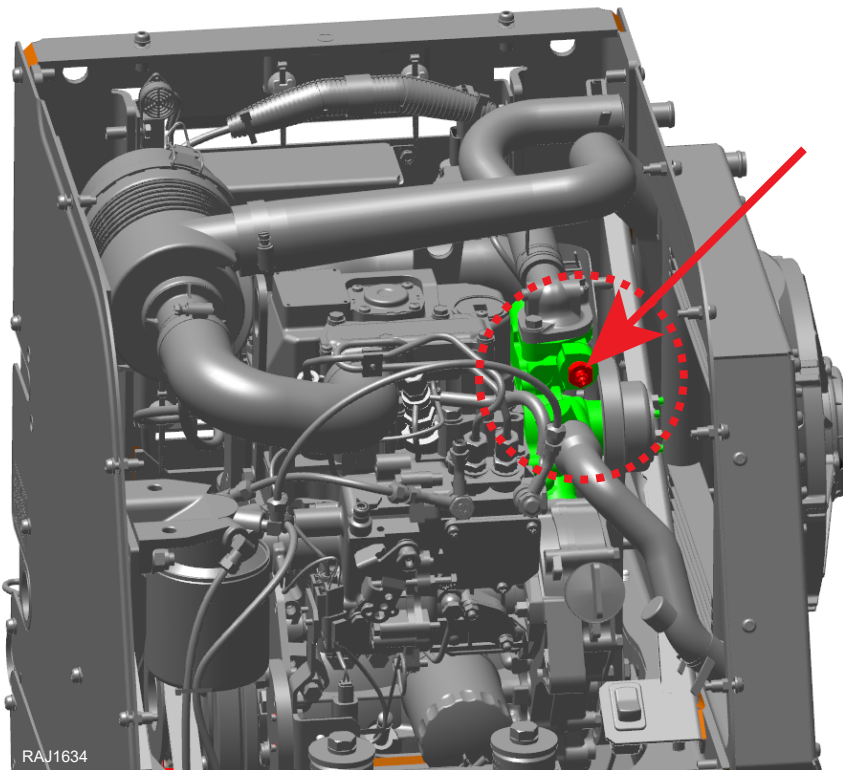

3. Slowly pour coolant into the expansion tank until a steady stream of coolant flows from the bleed valve, then close it and remove the hose.
4. Slowly pour coolant to the expansion tank until the coolant level is at the top of the window in the expansion tank.
5. Install the expansion tank cap.
6. Start the TriPac engine and use a non-contact thermometer pointed at the water pump bleed valve area to monitor the coolant temperature.

Notice

Equipment Damage!

Do not start the TriPac engine before a partial refrigerant charge has been added or damage to the A/C compressor will result.



THERMO KING

A/C System Charging and APU Engine Start-up Procedures

7. When the temperature reaches 150 F (66 C), shut off the engine for 2 minutes to allow the thermostat to heat soak and open completely to purge air out of block, head, and water pump.
8. Slowly remove the expansion tank cap and slowly pour coolant to the expansion tank until the coolant level is at the top of the window in the expansion tank, then reinstall the expansion tank cap.
9. After 2 minutes, re-start the engine.
10. Repeat steps 7 – 9 until the coolant level stabilizes. The TriPac APU cooling system should now be bled of all air.

Unit Setup Procedures

The TriPac 3 control system must be setup before performing the Run In Procedure and releasing unit to the customer. You will need to program the system configuration and programmable features based on unit options and customer requirements. While it is possible to complete the setup and programming settings via the HMI, it is recommended that WinTrac be used for these settings. This procedure will use the WinTrac communication software that is on the TriPac 3 Main Application Controller (MAC). An Internet connection is not required to operate WinTrac.

Note: *Unit serial number and in-service date need to be entered to clear Alarm 111.*

Required Tools

- PC computer with Internet Explorer 10 or higher.
- Interconnect cable USB-A to USB-C.

Opening WinTrac

1. Power HMI on.
2. Locate the USB interconnect cable attached to the MAC.
3. Connect interconnect cable to laptop computer running Microsoft Windows and Internet Explorer 10 or higher.
4. Open WinTrac application.

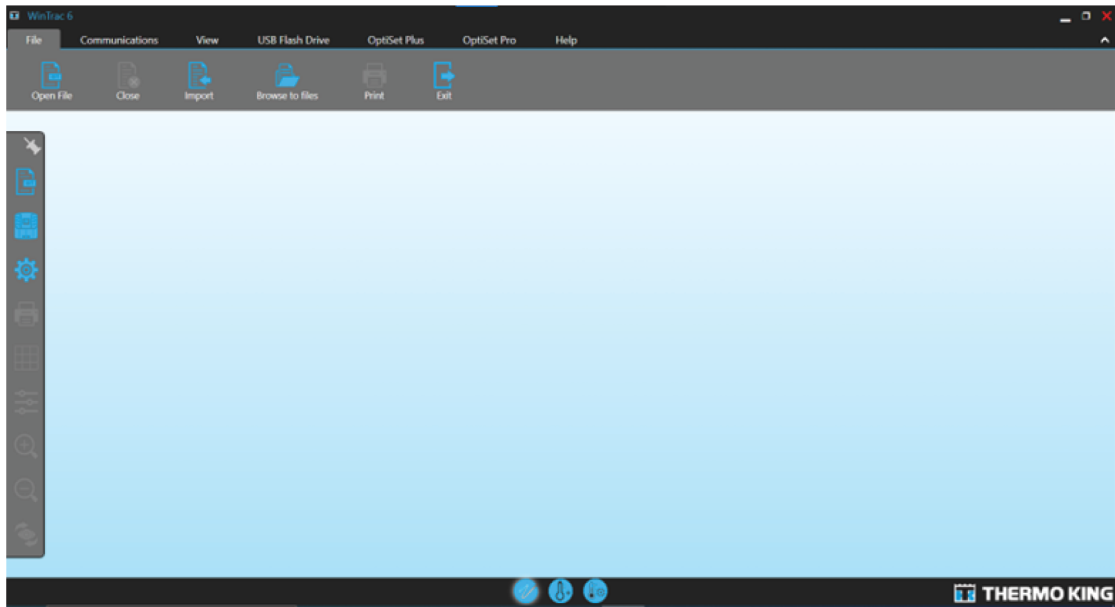

RCS2210

5. Select **Seek Device** on the left hand side of the screen.

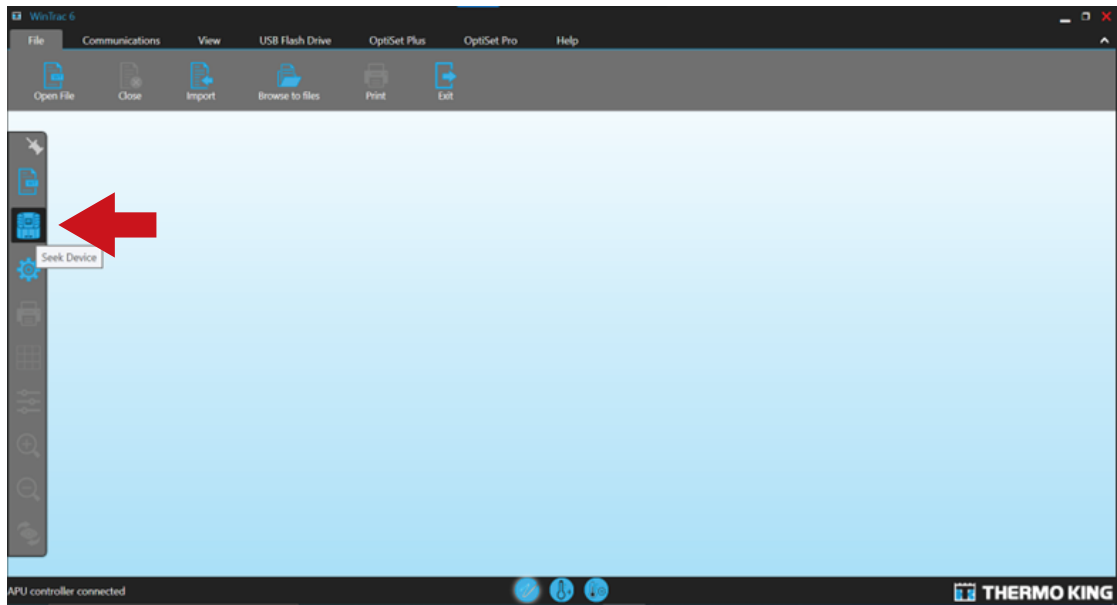

RCS2211-1

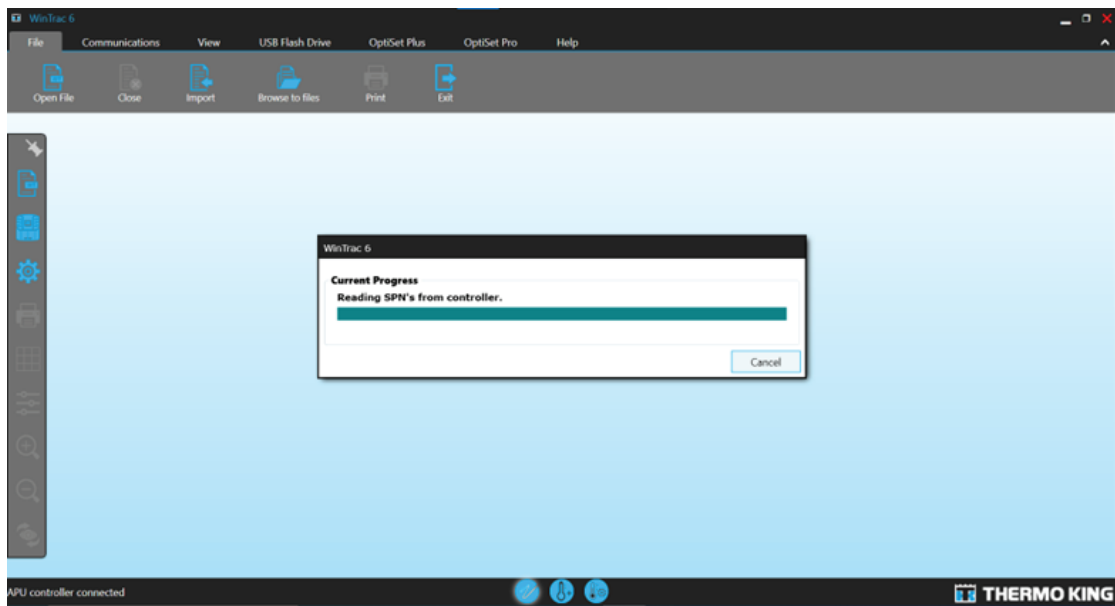

RCS2212-1

The unit is now connected to WinTrac.

Unit Information

1. Select **Unit Information** tab at the top of the screen, **double click** the empty **Unit Serial Number** box, and enter your unit's serial number.
2. Select **Update Unit** at the bottom of screen to save your information.

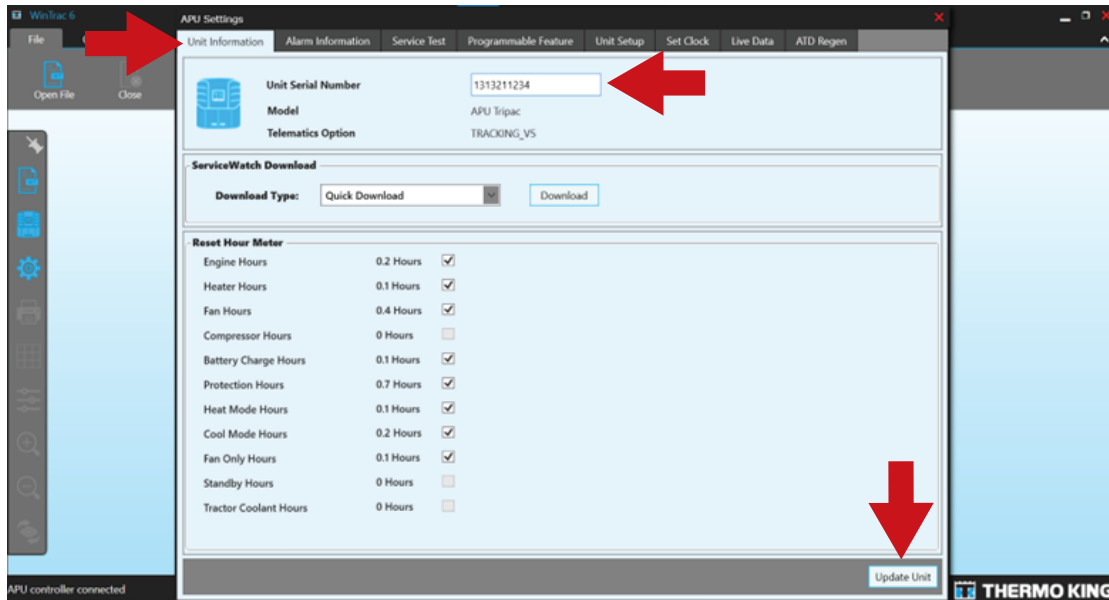

RCS2213-1

Unit Setup

Enter unit setup information as follows:

1. Select **Unit Setup** tab at the top of the screen.
2. Select **Model Number** and choose your unit:
 - M904613/M904671 is **without** ATD (Aftertreatment Device)
 - M904609/M904672 is **with** ATD (Aftertreatment Device)

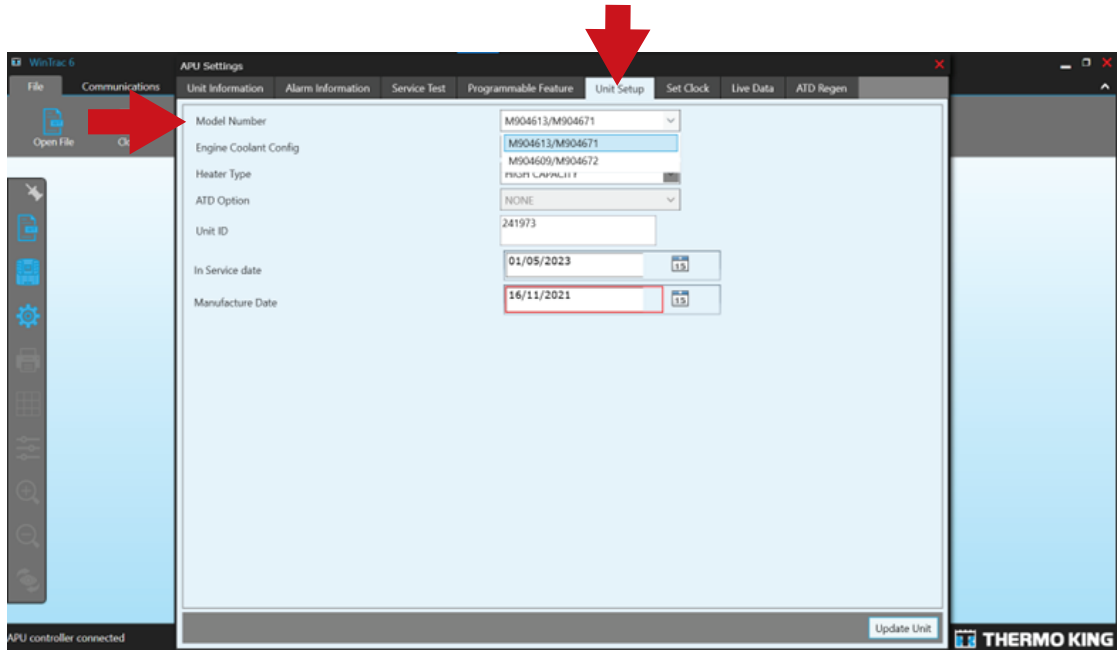

RCS2214-1

3. Select **Engine Cooling Config** and choose which type the unit has:

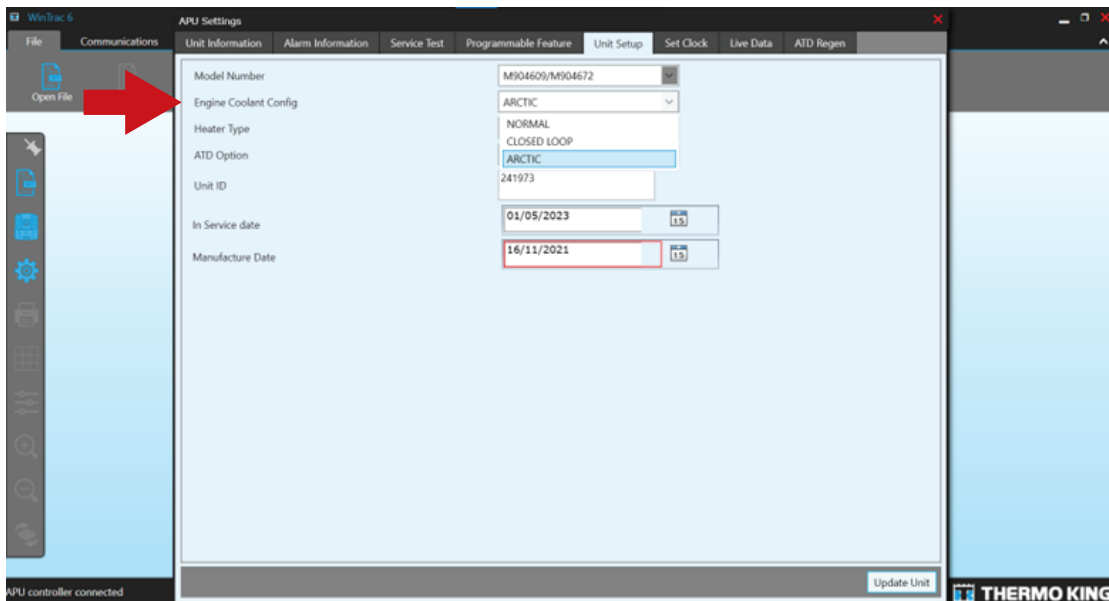

RCS2216-1

4. Select **Heater Type** and choose which type the unit has. Verify that the heater is set to standard (D2) or high (D4) capacity CAN depending on your heater size:

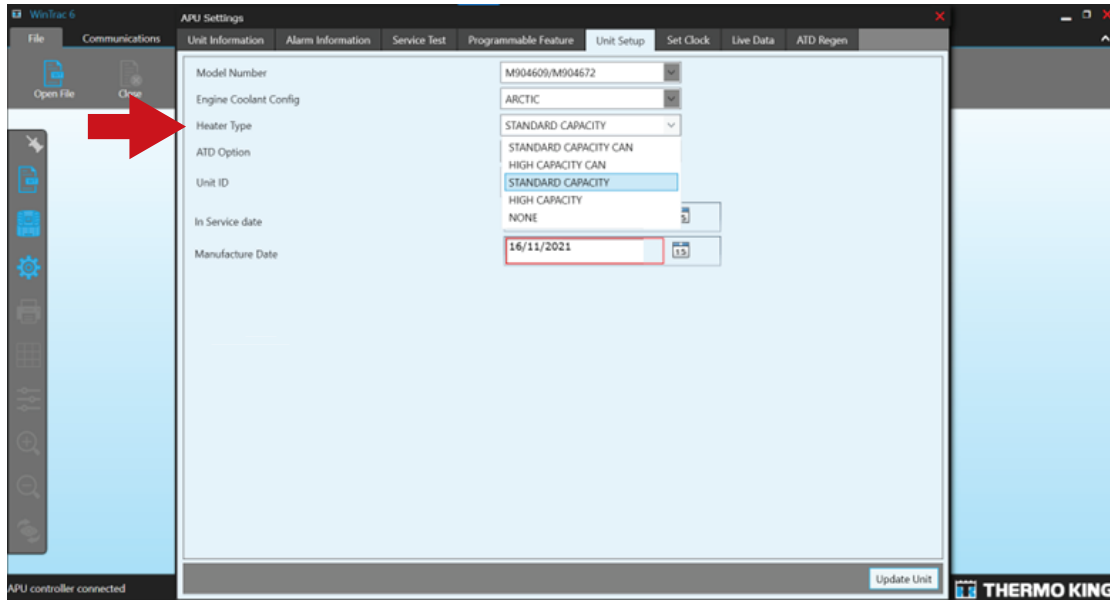

RCS2217-1

5. Select **In Service Date** and enter date customer takes delivery of unit.

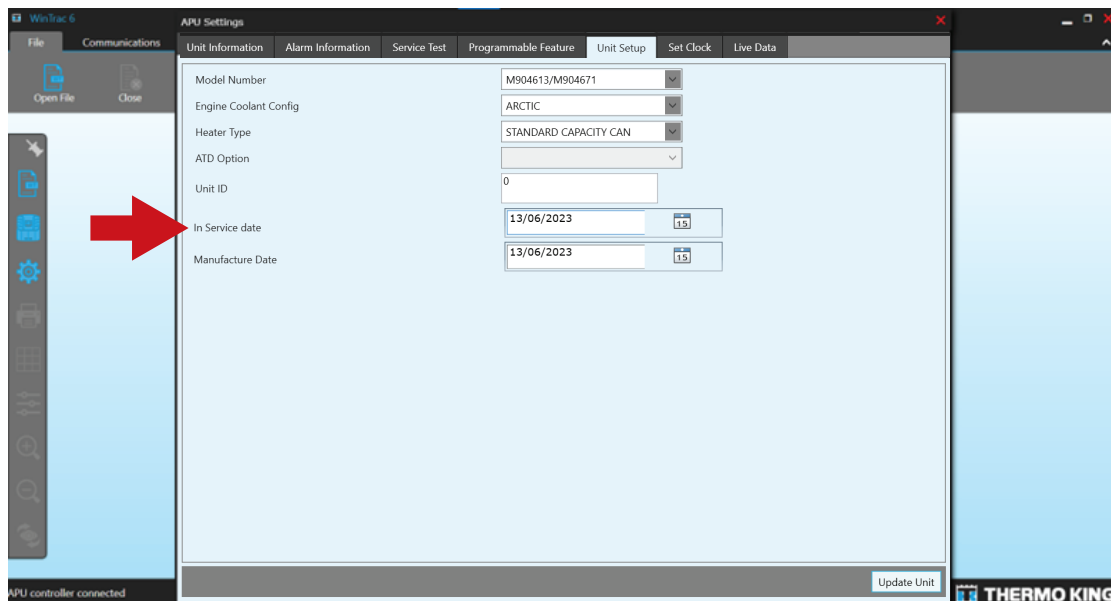

RCS2215-1

Unit Setup Procedures

6. Select **Manufacture Date** and enter date from unit serial plate.
7. Select **Update Unit** at bottom of screen to save all settings.

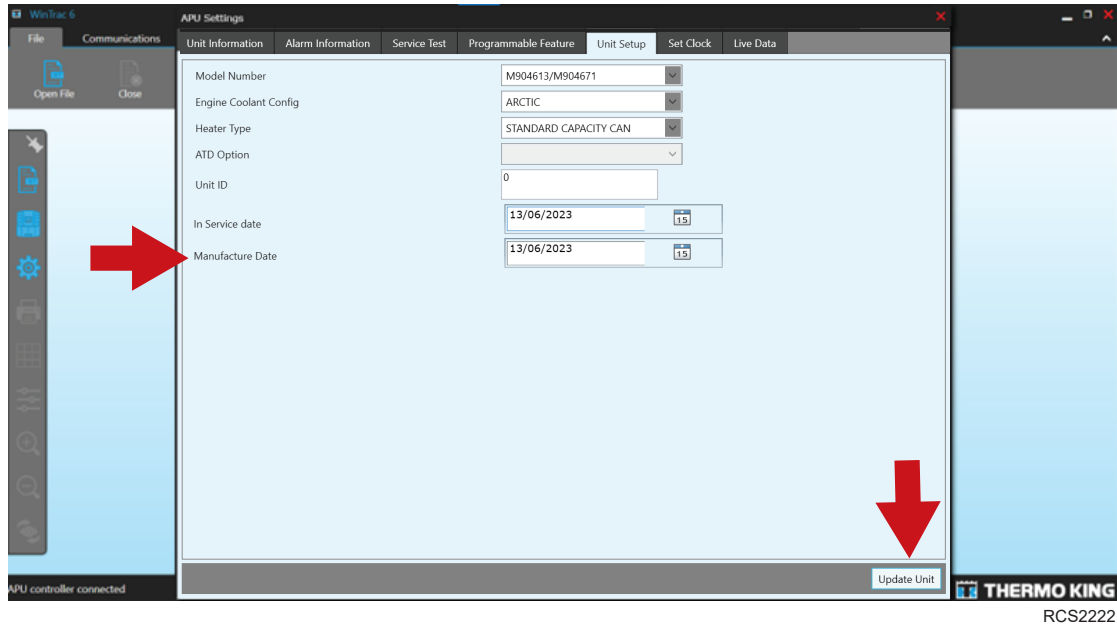

8. Select **Programmable Features** tab at the top of the screen and make changes as required.

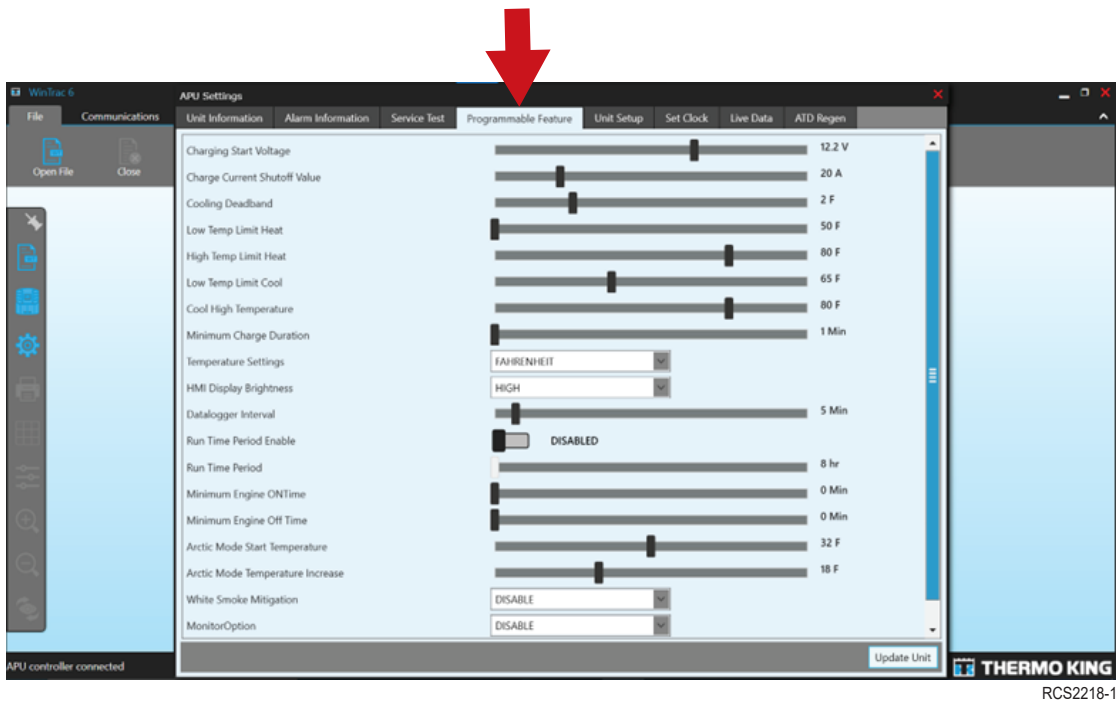

9. Select **Update Unit** at bottom of screen to save all settings.



Set Clock

The Real Time Clock should always be set to the current date and time.

1. Select **Set Clock** at bottom of screen to save settings.
2. Select **Set Clock** tab at the top of the screen and enter current date and time.

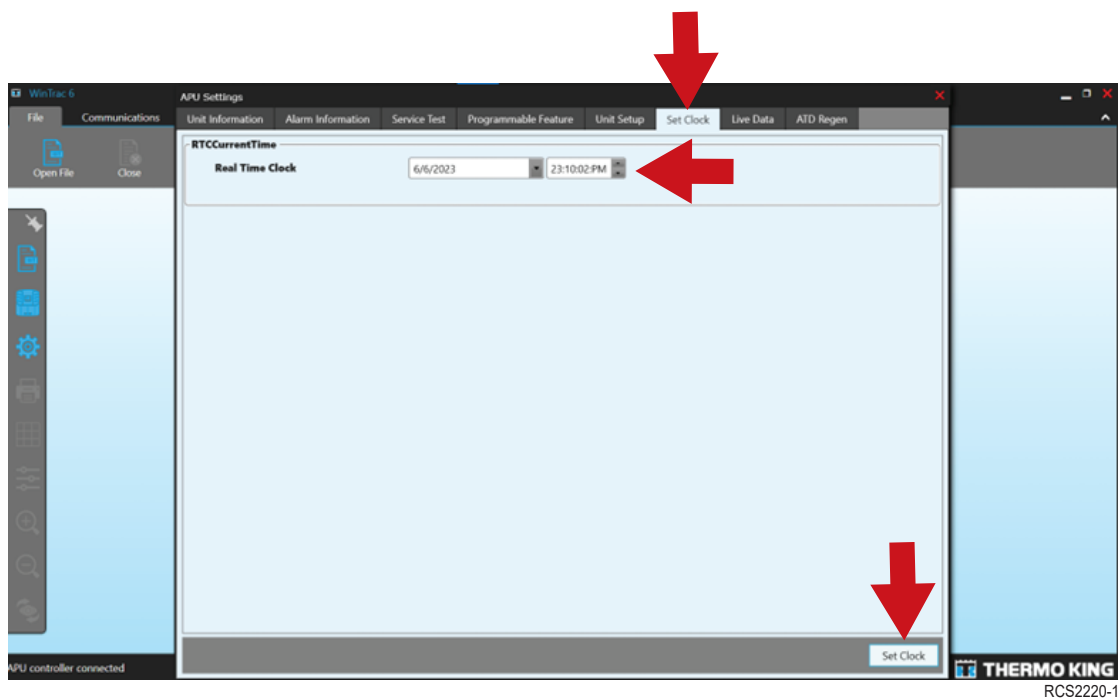

3. After entering data in the tabs, power the HMI off then on again to get the settings to save. A long press of the power button for five seconds will open the **Mode Selection** screen to shut down the unit.

Run-in Test

A 10 hour run-in test under load must be performed before delivery of a TriPac 3 unit to the customer. The Run in Test will force both the air conditioning system (using a low temperature setpoint) and the heating system (using a high temperature setpoint) to run for 10 hours.

This test will be done using the HMI and will stop automatically at the end of 10 hours.

1. Verify there is at least 5 gallons of fuel in the fuel tank to operate the system for 10 hours.
2. **Closed Loop Cooling Option Only** - Place a clean container under the overflow hose of the APU's overflow tank. This is to catch any coolant that may be expelled during the initial 10 hour engine run-in.
3. Select **Menu Button**.
4. Scroll to **Advanced Menu** then push **Select** button.

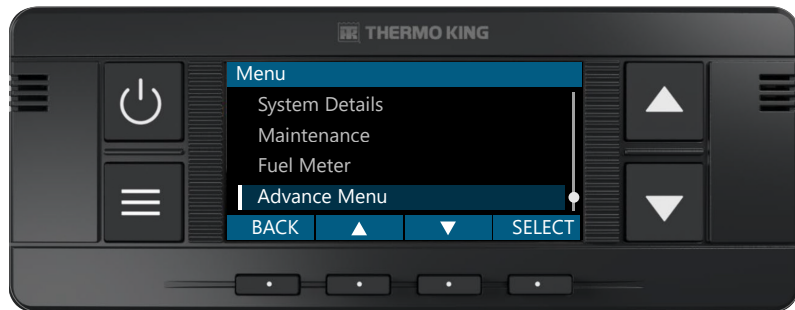

RCS2241

5. **ENTER PIN** — enter **0000** then push **Select** Repeat this 2 more times. The password will default to the last 4 digits of the serial number that was entered at the initial setup.

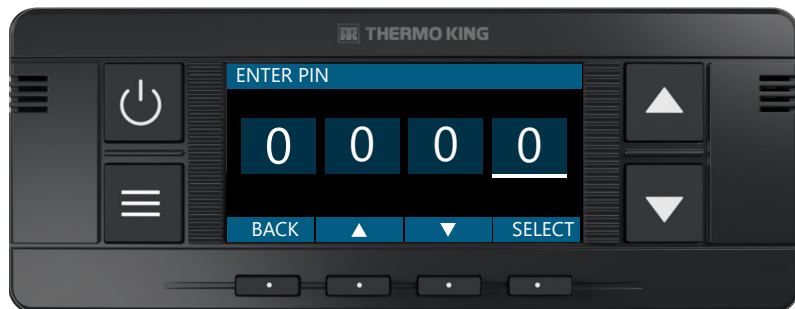

RCS2242

6. Select **Service Test**.

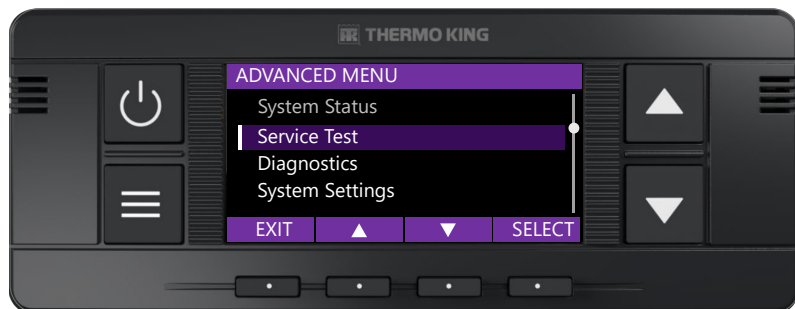

RCS2243

7. Select **Run-In Test**.

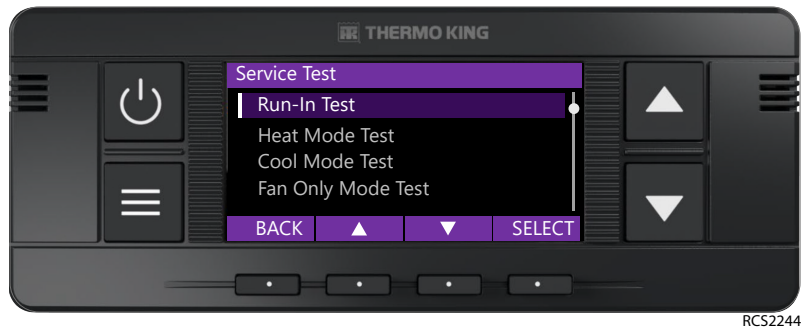

8. Select **YES**.



The APU engine will start and heater will ignite.

Note: Do not start truck after Service Test is initiated or the run in test will terminate.

If any other alarms are listed diagnose and repair as required. Refer to Diagnostic Manual TK 57117–19–MM or contact your authorized Thermo King Dealer.

9. After completing the Run-In Test, check engine oil level. Add oil as required.

Installing Nameplates (ATD Units Only)

Important: CARB requires this Verified Clean APS label be permanently affixed to the exterior on the driver's side of the hood, in an area one foot by one foot from the top and front edges of the hood and affixed to the driver's side door where shown below.

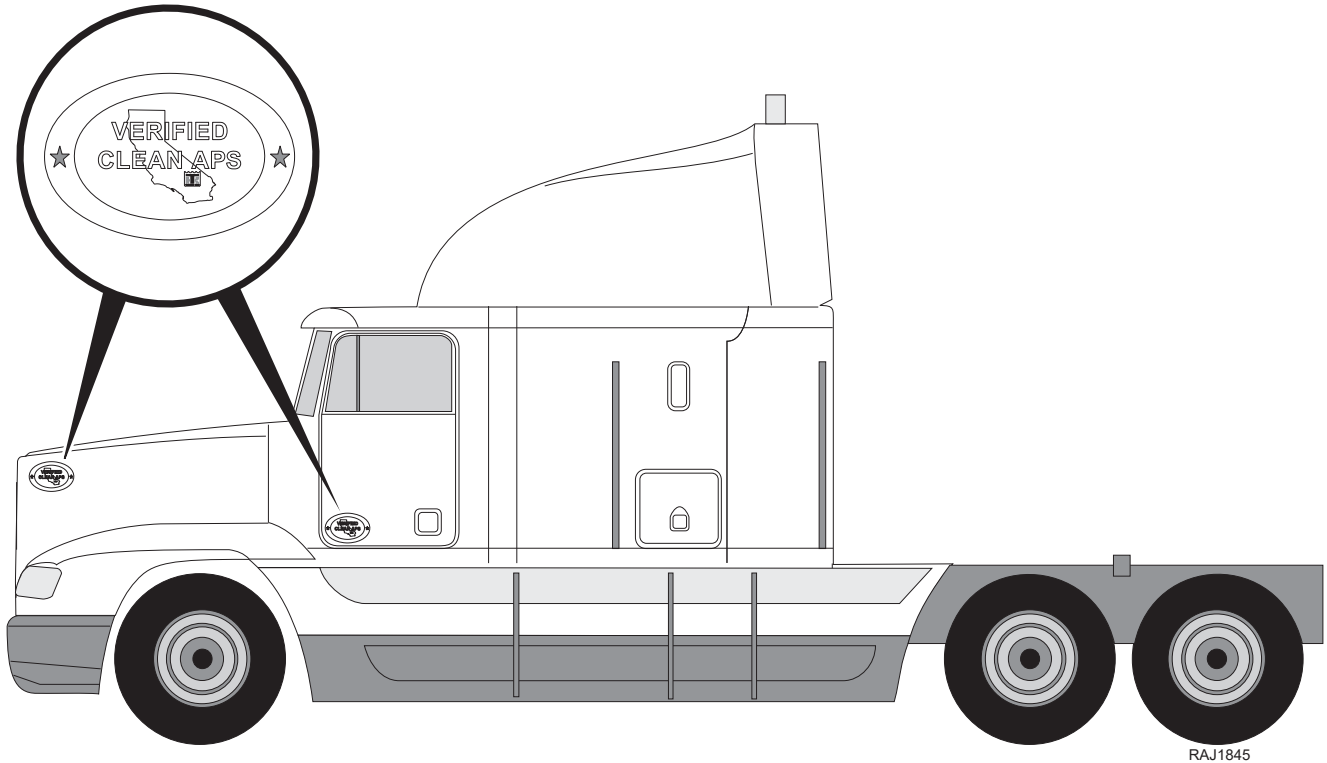

System Check List

- APU Mounting Bolts Positioned, Tightened and Torqued to Specs.
- Coolant Hoses Routed and Secured Properly
- Condenser Mounting Bolts Secured and Sealed with Silicone
- A/C Receiver Drier Mounting Bolts Secured
- A/C Evaporator Mounting Bolts Secured
- Evaporator Drain Tube Water Valves (Kazoos) Installed
- A/C Refrigeration Tubing Routed and Secured
- All Wiring Harnesses Routed, Connected and Secured
- A/C System Charged, Free of Leaks and Operates Correctly
- Heater Intake and Exhaust Hoses Routed Safely and Secured
- Heater System Operates Correctly
- All Fuel Lines are Routed Safely and Secured
- All Fuel Line Connections are Tight and Leak Free
- All Guards, Covers and Grilles Installed Securely
- 3" access hole in the sleeper floor is completely caulked from both inside and underneath
- Verified any unused holes in the sleeper floor are completely sealed closed with caulking
- Verify the unit has the latest software version in the MAC, RIO, and HMI through system details in the HMI. Check Asset Library for latest software version. Update if needed.
- All System Run-In Procedures Performed
- Coolant Levels for Truck and APU are Topped Off
- Unit Operated For 10 Hours
- Thoroughly Clean and Vacuum Interior of Sleeper
- Release to Customer

Thermo King – by Trane Technologies (NYSE: TT), a global climate innovator – is a worldwide leader in sustainable transport temperature control solutions. Thermo King has been providing transport temperature control solutions for a variety of applications, including trailers, truck bodies, buses, air, shipboard containers and railway cars since 1938. For more information, visit www.thermoking.com or www.tranetechnologies.com.

Thermo King has a policy of continuous product and product data improvements and reserves the right to change design and specifications without notice. We are committed to using environmentally conscious print practices.