



Operator's Manual

TriPac® Envidia™

Revision B

October 2020

TK 56460-19-OP-EN

TRANE
TECHNOLOGIES

Introduction

This manual is published for informational purposes only and the information furnished herein should not be considered as all-inclusive or meant to cover all contingencies. If more information is required, consult your Thermo King Service Directory for the location and telephone number of the local dealer.

Thermo King's warranty shall not apply to any equipment which has been "so installed, maintained, repaired or altered as, in the manufacturer's judgment, to affect its integrity."

Manufacturer shall have no liability to any person or entity for any personal injury, property damage or any other direct, indirect, special, or consequential damages whatsoever, arising out of the use of this manual or any information, recommendations or descriptions contained herein. The procedures described herein should only be undertaken by suitably qualified personnel. Failure to implement these procedures correctly may cause damage to the Thermo King unit or other property or personal injury.

There is nothing complicated about operating and maintaining your Thermo King unit, but a few minutes studying this manual will be time well spent.

Performing pre-trip checks and enroute inspections on a regular basis will minimize operating problems. A regular maintenance program will also help to keep your unit in top operating condition. If factory recommended procedures are followed, you will find that you have purchased the most efficient and dependable temperature control system available.

All service requirements, major and minor, should be handled by a Thermo King dealer for four very important reasons:

- They are equipped with the factory recommended tools to perform all service functions
- They have factory trained and certified technicians
- They have genuine Thermo King replacement parts
- The warranty on your new unit is valid only when the repair and replacement of component parts is performed by an authorized Thermo King dealer

Customer Satisfaction Survey

Let your voice be heard!

Your feedback will help improve our manuals. The survey is accessible through any internet-connected device with a web browser.

Scan the Quick Response (QR) code or click or type the web address https://tranetechnologies.iad1.qualtrics.com/jfe/form/SV_2octfSHoUJxsk6x?Q_CHL=qr&Q_JFE=qdg to complete the survey.



Table of Contents

Safety	7
Danger, Warning, Caution, and Notice.....	7
Safety Precautions.....	7
Inverter Operation Warnings.....	9
Refrigerant Oil Hazards.....	10
Refrigerant Hazards.....	10
First Aid.....	10
Safety Nameplates.....	12
Unit Description	13
Unit Features.....	13
Suggestions to Maximize Run Time.....	13
System Components.....	14
Battery Box.....	14
Evaporator/Control Box.....	15
Condenser and Receiver Drier.....	16
HMI Controller.....	16
Optional Heater.....	17
Control Circuits.....	17
Power Sources.....	17
Truck Integration.....	19
OEM Battery Pack.....	19
Alternator.....	19
Ignition Switch.....	19
Protection Devices.....	20
Air Conditioning System.....	20
Electrical System Fuses.....	20
Manual Pre-Trip Inspection	21
Before Starting the TriPac Envidia Unit.....	21

Operating Instructions	22
HMI Control Panel Operation	22
HMI Control Panel Display	22
On/Off Knob	23
Mode Selection	23
Temperature Selection	24
Fan Selection	25
Driver Selectable Settings	25
Icons	27
Battery Power Indicators.....	27
System Alarm Icons.....	28
Battery Alarm Icon	29
Battery Charging.....	29
Truck Running	29
Shore Power.....	31
Recommendations for Maximum Performance and Battery Run Time when in Cool Mode.....	32
Power Inverter (Optional)	33
Specifications	34
Electrical Control System.....	34
Fuses	34
Fuse Locations	35
Optional AC to DC Power Converter.....	36
Optional Power Inverter	36
Air Conditioning System	36
Optional Heater.....	36
Maintenance Inspection Schedule	37
Electrical.....	37

Structural 38

Air Conditioning System 38

Diesel Fuel-Fired Heater 39

TriPac Warranty 40

 Software License 40

Serial Number Locations 41

Emergency Cold Line 42

Safety

Danger, Warning, Caution, and Notice

Thermo King® recommends that all service be performed by a Thermo King dealer and to be aware of several general safety practices.

Safety advisories appear throughout this manual as required (refer to examples below). Your personal safety and the proper operation of this unit depend upon the strict observance of these precautions.

▲ DANGER

Example!

Indicates an imminently hazardous situation which, if not avoided, will result in death or serious injury.

▲ WARNING

Example!

Indicates a potentially hazardous situation which, if not avoided, could result in death or serious injury.

▲ CAUTION

Example!

Indicates a potentially hazardous situation which, if not avoided, could result in minor or moderate injury and unsafe practices.

NOTICE

Example!

Indicates a situation that could result in equipment or property-damage only accidents.

Safety Precautions

Thermo King recommends all services be performed by a Thermo King dealer. However, there are several general safety practices you should be aware of:

Safety**⚠ DANGER****Fire Hazard!**

Always turn the TriPac system OFF at the HMI Control Panel On/Off button while the truck is being refueled. Fuel vapors could ignite if they come in contact with TriPac electrical or heater components.

⚠ DANGER**Hazardous Voltage!**

The compressor and compressor controller operates with 220 Vac 1 phase voltage. Voltages of this magnitude can be lethal. All service should be performed only by a certified Thermo King technician.

⚠ WARNING**Personal Protective Equipment (PPE) Required!**

Always wear goggles or safety glasses when working with or around the refrigeration system or battery. Refrigerant or battery acid can cause permanent damage if it comes in contact with your eyes.

⚠ WARNING**Risk of Injury!**

Turn the unit HMI Controller Off before opening the Battery Box or inspecting any part of the unit.

⚠ CAUTION**Sharp Edges!**

Exposed coil fins can cause lacerations. Service work on the evaporator or condenser coils is best left to a certified Thermo King technician.

NOTICE**Equipment Damage!**

Do not connect other manufacturer's equipment or accessories to the unit unless approved by Thermo King. Failure to do so can result in severe damage to equipment and void the warranty.

Inverter Operation Warnings

⚠ DANGER

Risk of Injury!

Do not use the Thermo King Power Inverter in life support or health care applications where a malfunction or failure of the inverter could cause failure of a life support device or medical equipment or significantly alter the performance of that equipment.

⚠ DANGER

Hazardous Voltage!

Potentially lethal voltages exist within the power inverter as long as the battery supply is connected. During any service work, the battery supply should be disconnected.

⚠ DANGER

Risk of Injury!

Do not connect or disconnect batteries while the power inverter is operating from the battery supply. Dangerous arcing may result.

⚠ CAUTION

Risk of Injury!

Protect against possible electrical shock hazards. If the inverter is operated in wet or damp conditions a user-supplied, portable GFCI (ground fault circuit interrupter) must be connected between each inverter receptacle and the equipment it powers.

NOTICE

Equipment Damage!

You may experience uneven performance results if you connect a surge suppressor, line conditioner or UPS system to the output of the inverter.

NOTICE

Equipment Damage!

Some appliances or electronic devices may not operate properly when powered through a DC to AC power inverter. Refer to the owner's guide for each device to determine its compatibility.

Refrigerant Oil Hazards

Observe the following when working with or around refrigerant oil.

⚠ WARNING

Personal Protective Equipment (PPE) Required!

Protect your eyes from contact with refrigerant oil. The oil can cause serious eye injuries. Protect skin and clothing from prolonged or repeated contact with refrigerant oil. To prevent irritation, wash your hands and clothing thoroughly after handling the oil. Rubber gloves are recommended.

Refrigerant Hazards

Although fluorocarbon refrigerants (R-404A/R-452A and R-134a) are classified as safe, observe caution when working with refrigerants or around areas where they are being used in the servicing of your unit.

⚠ DANGER

Hazardous Gases!

Refrigerant in the presence of an open flame, spark, or electrical short produces toxic gases that are severe respiratory irritants which can cause serious injury or possible death.

⚠ DANGER

Refrigerant Vapor Hazard!

Do not inhale refrigerant. Use caution when working with refrigerant or a refrigeration system in any confined area with a limited air supply. Refrigerant displaces air and can cause oxygen depletion, resulting in suffocation and possible death.

⚠ WARNING

Personal Protective Equipment (PPE) Required!

Refrigerant in a liquid state evaporates rapidly when exposed to the atmosphere, freezing anything it contacts. Wear butyl lined gloves and other clothing and eye wear when handling refrigerant to help prevent frostbite.

First Aid

REFRIGERANT

- **Eyes:** For contact with liquid, immediately flush eyes with large amounts of water and get prompt medical attention.
- **Skin:** Flush area with large amounts of warm water. Do not apply heat. Remove contaminated clothing and shoes. Wrap burns with dry, sterile, bulky dressing to protect from infection. Get prompt medical attention. Wash contaminated clothing before reuse.
- **Inhalation:** Move victim to fresh air and use Cardio Pulmonary Resuscitation (CPR) or mouth-to-mouth resuscitation to restore breathing, if necessary. Stay with victim until emergency personnel arrive.
- **Frost Bite:** In the event of frost bite, the objectives of First Aid are to protect the frozen area from further injury, warm the affected area rapidly, and to maintain respiration.

REFRIGERANT OIL

- **Eyes:** Immediately flush with large amounts of water for at least 15 minutes. Get prompt medical attention.
- **Skin:** Remove contaminated clothing. Wash thoroughly with soap and water. Get medical attention if irritation persists.
- **Inhalation:** Move victim to fresh air and use Cardio Pulmonary Resuscitation (CPR) or mouth-to-mouth resuscitation to restore breathing, if necessary. Stay with victim until emergency personnel arrive.
- **Ingestion:** Do not induce vomiting. Immediately contact local poison control center or physician.

ENGINE COOLANT

- **Eyes:** Immediately flush with large amounts of water for at least 15 minutes. Get prompt medical attention.
- **Skin:** Remove contaminated clothing. Wash thoroughly with soap and water. Get medical attention if irritation persists.
- **Ingestion:** Do not induce vomiting. Immediately contact local poison control center or physician.

BATTERY ACID

- **Eyes:** Immediately flush with large amounts of water for at least 15 minutes. Get prompt medical attention. Wash skin with soap and water.

ELECTRICAL SHOCK

Take IMMEDIATE action after a person has received an electrical shock. Get quick medical assistance, if possible.

Safety

The source of the shock must be quickly stopped, by either shutting off the power or removing the victim. If the power cannot be shut off, the wire should be cut with a non-conductive tool, such as a wood-handle axe or thickly insulated cable cutters. Rescuers should wear insulated gloves and safety glasses, and avoid looking at wires being cut. The ensuing flash can cause burns and blindness.

If the victim must be removed from a live circuit, pull the victim away with a non-conductive material. Use wood, rope, a belt or coat to pull or push the victim away from the current. **DO NOT TOUCH** the victim. You will receive a shock from current flowing through the victim's body. After separating the victim from power source, immediately check for signs of a pulse and respiration. If no pulse is present, start Cardio Pulmonary Resuscitation (CPR). If a pulse is present, respiration might be restored by using mouth-to-mouth resuscitation. Call for emergency medical assistance.

ASPHYXIATION

Move victim to fresh air and use Cardio Pulmonary Resuscitation (CPR) or mouth-to-mouth resuscitation to restore breathing, if necessary. Stay with victim until emergency personnel arrive.

Safety Nameplates

Figure 1. Typical TriPac Envidia Safety Nameplates Shown

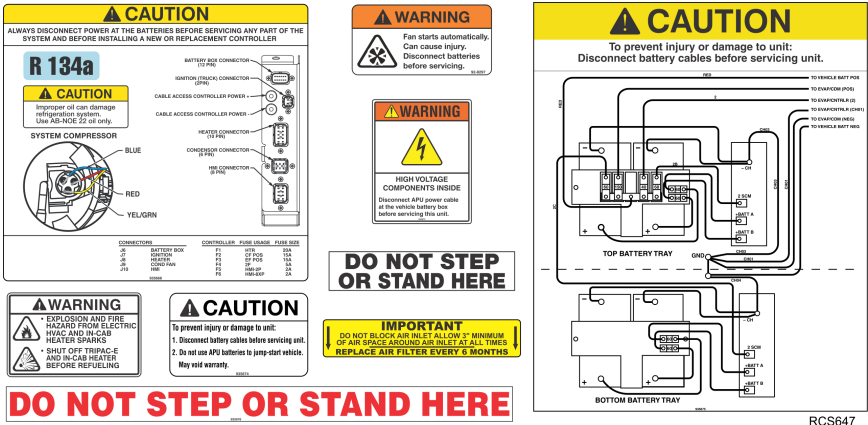

Unit Description

TriPac Envidia is an all-electric, battery based Auxiliary Heating and Cooling Temperature Management System. TriPac Envidia allows drivers to reduce unnecessary truck engine idling, conserve diesel fuel and save money.

TriPac Envidia's air conditioning provides sleeper compartment cooling in hot conditions. An optional fuel-fired air heater provides sleeper compartment heating in cold conditions. The all-electric operation and noise-dampening construction provides quiet operation for uninterrupted rest.

Thermo King's patented battery charging technology automatically maintains and charges the TriPac Envidia batteries when the tractor is on the road.

Optional Shore Power Converter provides the capability of running the TriPac Envidia system or charging the batteries if 115 Vac 15 Amp electrical power is available.

Note: *The system is designed for overnight driver comfort. Several hours of drive time are needed to charge the TriPac Envidia batteries before the next TriPac Envidia operation. Layover of more than one night may exhaust the TriPac Envidia battery reserve.*

Unit Features

- Easy to operate HMI Controller.
- Superior truck cab sleeper compartment cooling.
- Quiet and efficient variable speed hermetic (sealed) air conditioning compressor.
- Smart Charger Modules (SCM) ensures proper charging and discharging of the TriPac Envidia and tractor batteries to promote maximum battery life.
- Optional diesel fuel-fired sleeper compartment air heater.
- Optional 1000 Watt inverter for on-board appliances.
- Optional Shore Power converter to extend operating time and recharge batteries.

Suggestions to Maximize Run Time

Maximum climate control time is controlled by the total available power reserve in the TriPac Envidia and truck batteries. To achieve maximum run

Unit Description

time the operator should take steps to conserve power reserve by reducing power consumption, especially when outside temperature is high. Suggested steps include:

- Keep window curtains closed to reduce radiant heat that will increase cab temperature.
- Close curtain between cab and sleeper overnight to reduce air conditioning load.
- Limit the on time and number of cab lights and accessories to reduce battery power drain.
- Limit the on time and number of devices or appliances connected to the optional AC Power Inverter to reduce battery power drain.
- Plug into shore power when available. An optional power converter provides an additional source of power that will extend operation time.

System Components

The TriPac Envidia system includes several major components:

- Battery Box
- Condenser
- Evaporator/Control Box
- HMI Controller
- Heater (Optional)
- 1000 Watt Inverter (Optional)
- AC/DC Shore Power Converter (Optional)

Battery Box

The battery box is mounted to the truck frame rail. The battery box contains four Thermo King NXT Absorbed Glass Mat (AGM) Deep Cycle batteries. These batteries have been specifically designed for the TriPac Envidia system to maximize battery life and support deep discharge cycles. They provide increased power storage capacity for the system. The batteries are automatically charged by the tractor's alternator when the tractor is on the road.

Thermo King recommends that the tractor's batteries also be of the same type as the TriPac Envidia batteries for optimum performance and battery life.

NOTICE

Equipment Damage!

Do not use the TriPac Envidia batteries to jump start a vehicle. Severe damage to the TriPac Envidia batteries and electrical system will result.

Figure 2. TriPac Envidia Battery Box

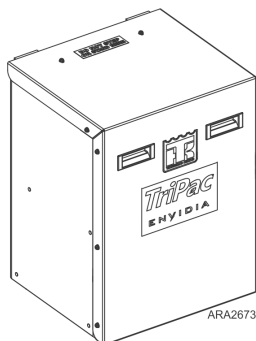

Evaporator/Control Box

The air conditioning evaporator/control box is typically installed under the bunk in the truck cab sleeper compartment. Air ducts from the evaporator/control box distribute cool air throughout the sleeper compartment.

The base controller and the electrical connections for the individual component are located on the side of the evaporator.

Figure 3. Evaporator/Control Box Shown

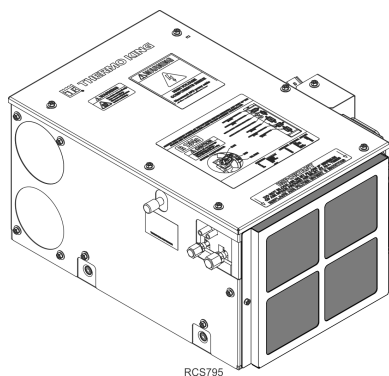

Condenser and Receiver Drier

The air conditioning condenser is mounted on the back of the truck cab. It contains a variable speed fan. The receiver/drier and the ambient temperature sensor are integrated on the housing.

Figure 4. Condenser and Receiver Drier

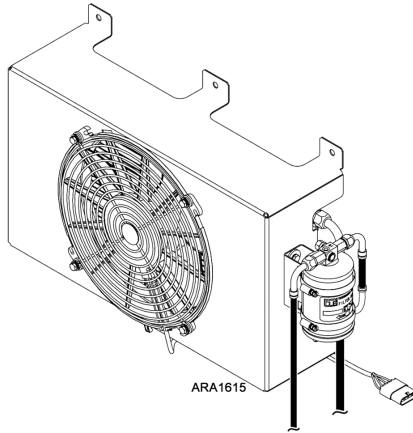

HMI Controller

The HMI controller is typically mounted in the bunk area. The HMI allows the driver to select the desired function of the system. It also provides alarm, battery level and system status feedback to the driver. The HMI has three selector knobs and a battery monitor display. The HMI also contains an integral Cab Temperature Sensor that helps control cab temperature when the TriPac Envidia air conditioning system is operating.

Figure 5. HMI Control Panel



Optional Heater

The optional fuel-fired air heater TriPac Envidia Heater is typically installed in the cargo compartment under the truck cab sleeper compartment. It draws fuel from the truck's diesel fuel tank and electric power from the TriPac Envidia batteries.

Figure 6. Heater

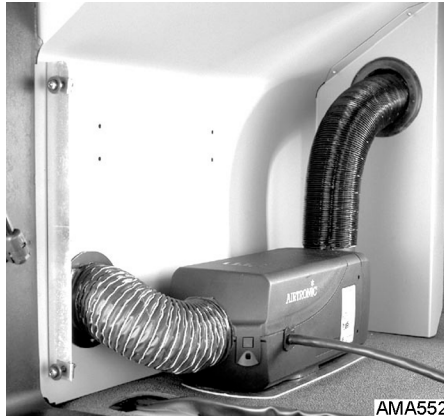

Control Circuits

The primary control circuits operate on 12 Vdc supplied by the system batteries. The compressor control circuits operate on 230 Vac supplied by the Compressor Drive Module.

Power Sources

All of the onboard batteries of a truck with the TriPac Envidia system can be thought of as a reservoir of electrical power. When the truck is parked, the TriPac Envidia system, and any other electrical devices in use, will consume the power in this reservoir. The faster the power is consumed the sooner the reservoir will be empty.

Unit Description

Note: *Use of truck accessories such as lights, refrigerators, TVs, etc., draws power from the batteries and will compete with the climate control electrical demand of the TriPac Envidia system. Heavy use of these devices and/or use of the optional 12 Vdc to 115 Vac Power Inverter will reduce the potential run time of the TriPac Envidia system. In addition, high ambient temperature will cause near continuous operation of TriPac Envidia air conditioning system and is aggravated by lowering the setpoint. This increased electrical demand will reduce the number of hours the system can control cab temperature. In high ambient conditions the driver should reduce the use of electrical accessories to a minimum to extend air conditioning time.*

The TriPac Envidia power management technology will make the most efficient use of the available power. The system will draw from the truck batteries and TriPac Envidia battery pack together. There is a Current Sensor around the interconnect cable between the TriPac Envidia batteries and truck batteries. It provides the Base Controller with information to help manage power flow. A pair of Smart Charger Modules (SCM) monitor and control power flow to and from the TriPac Envidia batteries. The SCMs provide the Base Controller with battery status information. The TriPac Envidia system may draw in excess of 80 amps during full air conditioning demand.

Power for the TriPac Envidia system comes from the following three sources. All system power is sent to a main fuse block in the TriPac Envidia battery box.

TriPac Envidia Battery Box: The TriPac Envidia Battery Box is the primary power source for the TriPac Envidia system.

Truck Batteries: The OEM truck battery bank is the secondary power source for the TriPac Envidia system.

Shore Power (Option): The optional Shore Power Converter is a 115 Vac to 12 Vdc power converter that provides low voltage power to the system. The Converter will help extend operation of the system before the batteries are depleted when the truck is parked and plugged into 115 Vac external or "Shore Power." During moderate ambient temperature conditions with moderate air conditioning demand the converter may support the system without draining the batteries. During high ambient temperature conditions with high air conditioning demand the converter will extend the operating time before the batteries are depleted. The Converter may also act as a secondary battery charging method during periods of low air conditioning or heating demand. The Converter is mounted in the cab, usually under the bunk. If the Shore Power Converter is plugged in while TriPac Envidia and all truck systems are off the converter will charge the Envidia and truck batteries.

If shore power is available, it should be connected when the batteries are near full charge to receive the full extended run time benefit of the Shore Power Converter.

Truck Integration

The TriPac Envidia APU system is integrated with the following OEM Truck systems.

OEM Battery Pack

The OEM truck batteries provide part of the power for the TriPac Envidia system. For base level system performance, there must be four 12 Vdc Group 31 batteries connected to provide 12 Vdc output. For optimum system performance the truck battery pack should be upgraded to four AGM type deep cycle batteries. These batteries have been specifically designed to support deep discharge cycles. Shorter system runtime will be experienced without the battery upgrade.

Alternator

The OEM truck alternator provides primary battery charging for the system while the truck is driving. It should be upgraded to a minimum of 270 amps. With some applications or truck operation profiles, such as short drive times or high system demand, increased battery charging capacity may be required. To provide the additional charging capacity the alternator and charging cables may need to be upgraded to 300 amps or above. Alternator and harness upgrades must be approved by the truck OEM.

Ignition Switch

When the truck ignition switch is turned to the On or Run position a signal is sent to the TriPac Envidia Base Controller. A three minute "Pull ahead" timer is activated and the system will continue to operate. If the switch is still on after three minutes the TriPac Envidia system will be turned off (disabled) and the system will begin a shutdown sequence. Once the sequence is complete, the system does not draw power from the batteries. The time delay prevents short cycling the system during short duration engine operation. If the truck engine continues to run, the battery charging process will begin. When the truck ignition is turned off, the TriPac Envidia system is defaulted off (disabled) and must be turned on (enabled) by the driver.

Protection Devices

Air Conditioning System

The Evaporator/Control box contains sensors that protect the Air Conditioning system.

- **High Pressure Cutout (HPCO) Switch** monitors air conditioning system pressure and generates an alarm if abnormally high system pressure occurs.
- **Compressor Overload Switch (OLS)** monitors compressor temperature and protects against high compressor temperature.

Electrical System Fuses

The electrical system is protected by a number of fuses. The fuses are located on the base controller, on the fuse block in the TriPac Envidia battery box, and in some of the harnesses.

Refer to ("[Fuses](#)," p. 34) in the Specifications Chapter for a list of the fuses and their locations.

Important: *All fuse replacement should be done only by a qualified service technician.*

Manual Pre-Trip Inspection

Pre-trip inspections are an important part of a preventative maintenance program designed to minimize operating problems and breakdowns. Perform this pre-trip inspection before every trip.

Important: *Contact your nearest Thermo King Dealer immediately if problems are found.*

Note: *Pretrip inspections are not intended to take the place of regular maintenance inspections.*

Before Starting the TriPac Envidia Unit

Structural: Visually inspect the unit for leaks, loose or broken parts, and other damage.

Condenser and Evaporator: Check and clean evaporator return air filter. Make sure the condenser and evaporator coils are clean and free of debris.

Ducts and Vents: Verify that air conditioning and heating vents are free of obstructions. Verify that air ducts under bunk are not crushed or kinked.

Heater: Verify heater air intake tube and exhaust pipe under truck are in place, not kinked and free of obstructions.

General: Listen for unusual noises and vibrations.

Operating Instructions

HMI Control Panel Operation

The TriPac Envidia is operated using an HMI (Human Machine Interface) Control Panel which is typically mounted on a wall in the truck cab sleeper compartment.

Figure 7. HMI Control Panel

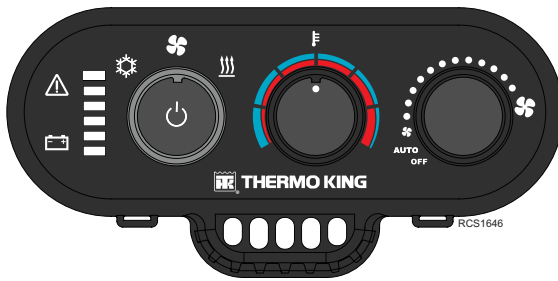

HMI Control Panel Display

The HMI is an easy to use control that allows the driver to select the desired function of the system. It also provides feedback to the driver of alarms, battery level and system status. The HMI has three selector knobs and a battery monitor display. The HMI also contains an integral Cab Temperature Sensor.

The driver can select these functions from the HMI:

- System On/Off
- Mode (Cool, Fan, Heat)
- Desired Cab Temperature (Cooler or Warmer)
- Fan Speed (OFF, Auto, Variable)
- Driver Selectable Settings

When any setting change occurs, there will be a two second delay before the controller recognizes the new setting. The Mode Icon will flash until mode is confirmed by the Base Controller.

⚠ DANGER

Risk of Injury!

Always turn the unit off while refueling the truck. Fuel vapors could ignite if they come in contact with electrical or heater components.

On/Off Knob

The left knob on the HMI face functions as the On/Off switch. Functions are accessed by pressing the left knob.

Figure 8. Press Knob for On or Off



Turn System On: If the system is off, press the left knob for at least 1 second to turn the system on. Less than that is a bump that does not turn the system on.

Turn System Off: If the system is on, press the left knob for more than 2 seconds to turn the system off.

Other operation features can be accessed, depending on how long the left knob is pressed. See “Driver Selectable Settings”.

System Status Display: If the system is off, press the left knob for less than 1 second. Battery and alarm status will display.

Note: *Pressing the left knob for less than 1 second is referred to as a “bump”.*

Mode Selection

Mode selection is accomplished by *rotating* the left knob. It selects between **Cool**, **Fan**, and **Heat** operating modes. A mode icon will blink for a few seconds then light indicating the selection. There will be a two second delay

Operating Instructions

before the new mode is activated to prevent momentary or accidental mode changes.

Figure 9. Mode Selection

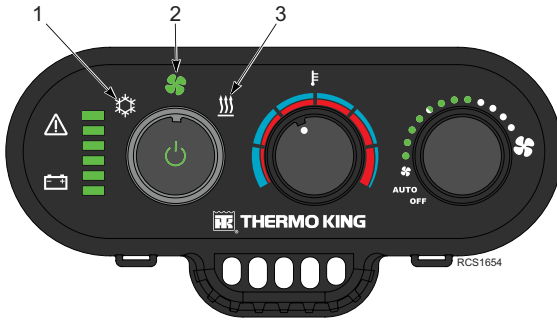

1.	Cool Mode	2.	Fan Only Mode	3.	Heat Mode
----	-----------	----	---------------	----	-----------

Temperature Selection

Temperature selection is accomplished by rotating the center knob. It selects the desired cab temperature cooler (**blue**) or warmer (**red**). Adjust to driver comfort. Refer to (["Recommendations for Maximum Performance and Battery Run Time when in Cool Mode,"](#) p. 32).

Figure 10. Center Knob Adjusts Temperature

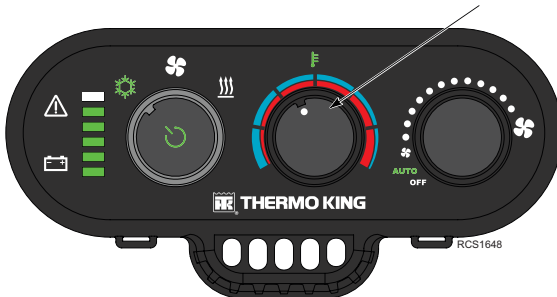

Fan Selection

Evaporator fan speed is adjustable. Rotating the **Fan** selector knob clockwise will increase fan speed; counterclockwise will decrease fan speed.

Figure 11. Right Knob Adjusts Fan Speed

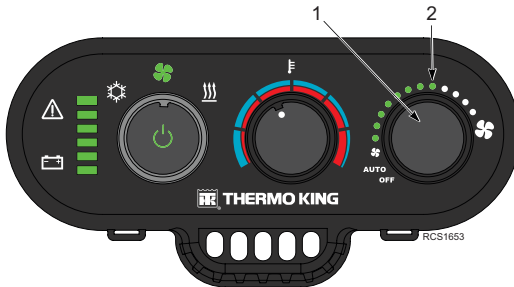

1.	Fan Selector	2.	LEDs
----	--------------	----	------

As fan speed increases LEDs will progressively turn on. As fan speed decreases, LEDs will progressively turn off. The fan will continue to run at the chosen speed.

- AUTO fan speed is the default fan setting when Cool mode is selected. This allows the Base Controller to make fan speed decisions for optimum performance.
- OFF may be selected when in Fan or Heat mode.
- OFF is the default setting when Heat or Fan mode is selected.

Driver Selectable Settings

From the HMI the driver will have access to three additional selectable features. To access these features the driver will use a sequence of “bumps” on the On/Off (left) button. Pressing the On/Off button for ½ second is a bump.

Important: *The Selectable Settings Mode must be exited before the system will resume normal operation.*

- **Alarm Clearing:** Most active system alarms can be cleared from the HMI.
 - TriPac Envidia system is on and the alarm icon is on.

Operating Instructions

- Bump the On/Off button three times to enter the Selectable Settings Mode.
- Press the On/Off Button for 5 seconds to clear the alarms. The alarm icon should turn off. If the alarm condition still exists the alarm will reoccur.
- Bump the On/Off button three additional times to exit the Selectable Settings Mode.
- **HMI Dim:** The brightness of the HMI display LEDs can be changed.
 - The TriPac Envidia system is on.
 - Bump the On/Off button three times to enter the Selectable Settings Mode.
 - Rotate the Fan Speed knob to change display brightness.
 - Bump the On/Off button three additional times to exit the Selectable Settings Mode.
- **Shore Power Charging:** Available if the optional AC to DC Shore Power Converter is installed and plugged-in to an external 115 Vac source. Can be used to charge system batteries while TriPac Envidia and truck systems are off. Taking no action will charge only the truck batteries. The driver may manually select to allow the TriPac Envidia system to immediately switch to charge mode if truck battery voltage is above 13 Vdc. Shore Power Charging must be selected each time the feature is desired.

***Note:** If the system is turned Off at the HMI, after a 15 minute delay the system will automatically sense if Shore Power is connected. It will allow the TriPac Envidia batteries to charge if System Voltage rises above 13.5 Vdc.*

 - Turn the truck ignition and TriPac Envidia system off.
 - Bump the On/Off button once to activate the System Status Display.
 - Bump the On/Off button three times to enter the Selectable Settings Mode.
 - Bump the On/Off Button an additional two times to toggle the feature.
 - Bump the On/Off button three additional times to exit the Selectable Settings Mode.
 - After about 20 seconds the green Battery Monitor bars should begin to scroll up. This indicates the TriPac Envidia system is in charge mode. Refer to Battery Charging in this section.

Icons

The HMI displays Battery Monitor icons, Low Battery icon, and Alarm icon.

Battery Power Indicators

While the system is operating the six Battery Power Indicators illuminate displaying the amount of auxiliary battery power available. When the system is first turned on it will take approximately 20 seconds for the battery power indicators to accurately display. The battery monitor system uses a weighted calculation with Envidia batteries representing about 80% of the power reserve. When the Envidia batteries are depleted there should be 2 Yellow indicators displayed. They represent the reserve in the truck batteries.

Green bars will scroll up while truck ignition is on. This indicates the TriPac Envidia system is in Charge Mode. It does not indicate the TriPac Envidia batteries are charging.

Figure 12. Battery Power Indicators

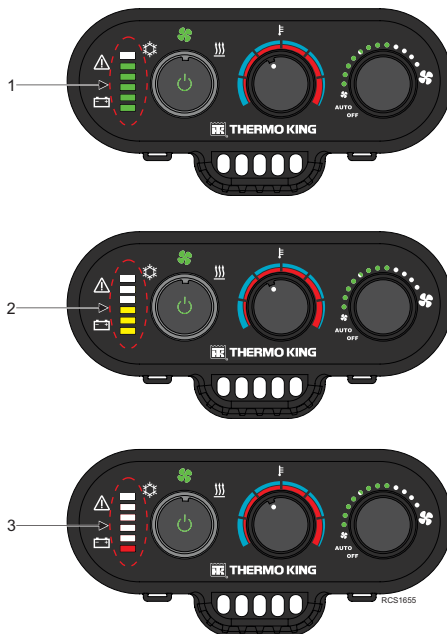

1.	4 - 6 Green Bars = Power 50% to 100%	2.	2 - 3 Green Bars = Power 15% to 50%	3.	1 Green Bar = Power less than 15%
----	---	----	--	----	--------------------------------------

System Alarm Icons

The alarm icon (Yellow or Red) will alert the driver that an abnormal condition exists.

- Yellow = Check Alarm. This type of alarm indicates the system has an abnormal condition that should be checked by a Thermo King technician at the next opportunity. The system will continue to operate but may have reduced capacity.
- Red = Shutdown Alarm. This type of alarm indicates a system fault that should be checked by a Thermo King technician immediately. The system will not operate with this alarm active.

To Clear Alarms: Turn the system Off then On at the HMI. Active alarms will clear. The Alarm icon should go out. If it does not or immediately returns the alarm condition still exists.

Alarms may also be cleared while the system is on. Bump the On/Off button three times then hold it for five seconds. Bump three more times.

Important: If system alarms continue to appear, contact an authorized Thermo King Dealer.

Figure 13. System Alarm Icons Shown

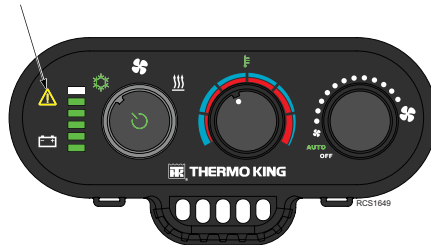

Battery Alarm Icon

If the system has turned off for low power reserve, it may be turned on by pressing the On/Off button on the HMI for at least one second. The system batteries should have been fully charged by running the truck before turning the system on again. If the batteries are not charged, the system may immediately turn off for low power reserve or have very short run time.

Repeated partial charging then fully discharging the system batteries will reduce battery life.

- Red = System off due to low power reserve. System voltage has fallen below 12.3 Vdc. The SCMs have switched to Null and HVAC systems have been disabled preventing further discharge of the system batteries.

Note: *The truck batteries will be the last voltage available. The HVAC system will continue to operate after the Envidia batteries are depleted.*

Figure 14. Battery Alarm Icon



Battery Charging

Truck Running

Charging amperage is provided by the truck alternator. A 270 amp alternator is the minimum required to support the TriPac Envidia system. For many applications or truck operation profiles, such as high tractor duty load, high driver "Hotel Load", extended layover duration, high ambient temperature or short drive times between layovers, increased battery charging capacity may be required. Undersized alternators will increase TriPac Envidia charge time. The truck alternator will spend a higher percentage of operating time at maximum output. This may shorten the life of the truck alternator. To provide the additional charging capacity, the alternator and charging cables

Operating Instructions

will need to be upgraded to 270 amps or more. Verify that alternator and charging cable upgrades are accepted by the truck OEM.

Battery charging will take place in progressive stages that prevents an extremely high alternator charge rate. The process begins when the truck engine is started. The SCMs will be put in Null mode. All TriPac Envidia batteries will be isolated. The truck batteries will begin charging first.

Note: *While the truck is idling there may not be enough amperage produced by the alternator to effectively charge the batteries. Many alternators may require a minimum of 1,200 RPM before effective battery charging is available.*

If the TriPac Envidia system is on when the truck is started, the three minute Pull Ahead timer must expire followed by a four minute system check before the charging process will begin. If the TriPac Envidia system is off when the truck is started, the Base Controller wakes up to check IGN circuit status periodically (every five minutes during first three days, every 15 minutes days 4-6, once per hour after day 6). If it is on, the charging process will begin.

The TriPac Envidia Base Controller will monitor System Voltage. When it rises above 13 Vdc, the Base Controller will begin adding one SCM at a time to the charging process if there is excess charging capacity available from the alternator. Each SCM is capable of charging one battery at 40 amps. First the Base Controller will check each battery. It will put one of the SCMs in Charge mode. It will then choose to charge the battery with the lowest state of charge. As a result, SCM1 battery A may not be the first to begin charging.

Note: *A battery must be above 9.5 volts for the SCM to recognize it for charging. A battery below this voltage should be tested then externally charged before adding it back into the system. A red flashing LED on the SCM will indicate a battery that is under voltage and isolated.*

If System Voltage does not drop significantly when a battery is added, the SCM will remain in Charge mode. If System Voltage does drop there is insufficient reserve charging capacity, the truck batteries are not sufficiently charged. The SCM will return to Null mode for 15 minutes then retry. The SCM will continue trying to engage Charge mode until it is successful.

Once the first SCM is in Charge mode for a time the Base Controller will attempt to add the second SCM to the charging process. It will perform the same steps until it has both SCMs charging one battery each. The truck alternator is now charging six batteries; four in the truck and two in the TriPac Envidia battery box. The SCMs will bring their first batteries to 80% state of charge then switch to their second batteries until all batteries are at

80% state of charge. The SCMs will switch back to the first battery to finish charging to 100% followed by the second battery. Once charging has started, if System Voltage falls below 11.5 Vdc, the TriPac Envidia battery charging will stop.

Total battery charging time is expected to be 4 to 8 hours depending on depth of discharge, traffic, driving profile and alternator size. The six Battery Monitor bars will scroll up in green while the truck engine is running and alternator is charging. Battery charge state can be read at the HMI while the HVAC system is off by bumping the On/Off selector for less than one second.

Shore Power

Connect the optional 115 Vac to 12 Vdc Shore Power Converter to external Shore Power. Requires a 115 Vac, 15 amp power source. If the optional AC to DC Shore Power Converter is installed and Shore Power is available it should be connected to external power as soon as possible after the truck is parked. The converter will provide 13.6 Vdc at up to 85 amps to the truck batteries. This additional amperage helps to keep the truck batteries at a high state of charge while supporting driver "Hotel Load" and power sharing with the TriPac Envidia system. The primary function of the AC to DC Shore Power Converter is to extend HVAC operating time.

Note: *The Shore Power Converter should not be connected if the truck is running.*

HVAC System On

If the combined amp draw from the truck batteries of the TriPac Envidia HVAC system, truck systems and DC to AC Power Inverter is less than the available 85 amp output of the AC to DC Shore Power Converter, the truck battery pack may begin charging. The TriPac Envidia batteries will not charge with the HVAC system on.

HVAC System Off

The Base Controller monitors System Voltage. While the system is off, the Real Time Clock momentarily wakes up the Base Controller periodically (every five minutes during first three days, every 15 minutes days 4-6, once per hour after day 6). It will check System Voltage. If it rises above 13.5 Vdc the system will automatically recognize Shore Power Charging and enter charge mode. This will allow the SCMs to charge the Envidia batteries. If System Voltage falls below 13 the charging of the Envidia batteries will stop. The truck batteries will continue to charge.

Recommendations for Maximum Performance and Battery Run Time when in Cool Mode

The following recommendations will help provide maximum performance and run time when in **COOL MODE**:

- Avoid direct sunlight on windshield during parking.
- Close sleeper curtain and window covers.
- Use vehicle air conditioner to pre-cool cab. **DO NOT** use TriPac Envidia for cab/sleeper temperature pull down!
- Minimize inverter loads (appliances, etc.) during long rest stops.
- Keep temperature selection in **GREEN** area as shown.
- Keep fan speed selection in **AUTO** mode as shown. AUTO is the default and recommended fan speed setting for best power management.

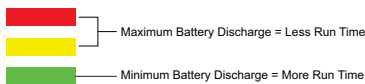

Power Inverter (Optional)

Important: See Safety Section regarding power inverter operation. Manufacturer's instructions for the inverter are provided separately. It is important to read and follow those instructions for proper use of the inverter.

If the TriPac Envidia is enabled and the inverter draws system battery voltage down below the voltage limit established for the installation, the TriPac Envidia system will shut down.

Note: Thermo King recommends that 800 watt or smaller microwave ovens be used with the optional TriPac Envidia power inverter.

Figure 15. Thermo King 1000 Watt Power Inverter



Specifications

Electrical Control System

Control System Voltage	12 Vdc
Batteries	TriPac Envidia Battery Box: Four Thermo King NXT, AGM, Deep Cycle Truck Battery Box: Four, Group 31, 1150 CCA Minimum, (Thermo King NXT Recommended)
Alternator	Truck mounted, 12 V, 270 amp minimum required (300 amp recommended)

Fuses

Fuse Number	Location	Amp Rating	Component Protected / Circuit - Connector
F1	Base Controller Fuse Panel	20	Heater/HTR1
F2	Base Controller Fuse Panel	15	Condenser Fan/CFPOS
F3	Base Controller Fuse Panel	15	Evaporator Fan/EFPOS
F4	Base Controller Fuse Panel	5	Controller/2F
F5	Base Controller Fuse Panel	2	HMI/2P
F6	Base Controller Fuse Panel	2	HMI/8XP
F7	Heater Harness	5	Heater/RED
F8	Vehicle Ignition Harness	1	Ignition Input/IGN
F9	Fuse Block in Battery Box	60	Smart Charger 2/2C
F10	Fuse Block in Battery Box	150	Compressor Drive Module (CDM)
F11	Fuse Block in Battery Box	40	Base Controller/2
F12	Fuse Block in Battery Box	60	Smart Charger 1/2B
F13	Fuse Holder in Positive Battery Harness	175	Truck Batteries/RED
F14	Fuse Holder in Positive Inverter/ Converter Harness	150	Inverter/Converter/RED

Fuse Number	Location	Amp Rating	Component Protected / Circuit - Connector
F16	Fuse Block in Battery Box	60	System Battery B/RED
F17	Fuse Block in Battery Box	60	System Battery A/RED
F18	Fuse Block in Battery Box	60	System Battery B/RED
F19	Fuse Block in Battery Box	60	System Battery A/RED

Fuse Locations

Important: All fuse replacement should be done only by a qualified service technician.

Fuses are located inside Battery Box and behind the access panel of the Base Controller.

Figure 16. Fuses Inside Battery Box

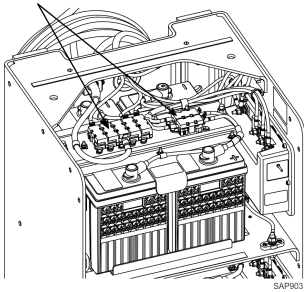
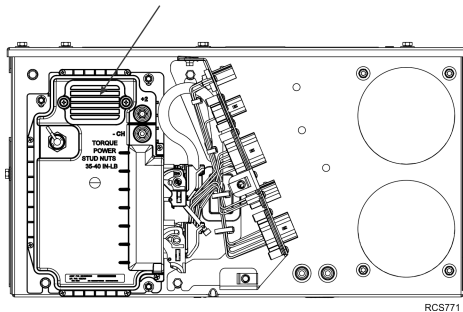

Figure 17. Fuses Inside Base Controller



Specifications**Optional AC to DC Power Converter**

Extension Cord Size:	Length Up to 75 ft. (22 m) – 14 AWG
Extension Cord Type:	Length 76 to 145 ft. (23 to 44 m) – 12 AWG SJOOW Thermoset oil and water resistant -40 to 194 F (-40 to 90 C) [minimum]

Optional Power Inverter

Input Voltage Range	10.5 to 15.5 Vdc
Output Voltage	104 to 127 Vac
Output Frequency	60 Hz
Output Waveform	Pure Sine Wave
Continuous Power Output	900 Watts
Peak Power Output	1000 Watts for 5 Minutes
Power Output Surge Rating	2000 Watts
Outlet Quantity / Type	2 / GCFI
USB Charge Port Output	5 Vdc / 500 mA
Low Input Voltage Alarm	11.0 Vdc
Working Temperature Range	32 to 149 F (0 to 65 C)

Air Conditioning System

The TriPac Envidia air conditioning system must be serviced by an authorized Thermo King Dealer.

Optional Heater

The TriPac Envidia diesel fuel-fired air heater must be serviced by an authorized Thermo King Dealer.

Maintenance Inspection Schedule

Thermo King recommends all maintenance and service procedures be performed by an authorized Thermo King dealer.

Note: *Thermo King reserves the right to deny warranty coverage on claims due to lack of maintenance or neglect. Claims in question must be supported by maintenance records.*

Electrical

Pretrip	Semi-Annual 1,000 Hrs	Annual 2,000 Hrs	
			Check condition of or service the following:
	•	•	Check tractor alternator operation and voltage per OEM specifications.
	•	•	Verify indicator LEDs on the Smart Charger Modules (SCM) are illuminated green.
	•	•	Inspect and clean all tractor and TriPac Envidia battery terminals.
	•	•	Inspect TriPac Envidia electrical connections for cleanliness and tightness.
	•	•	Inspect TriPac Envidia wire harness and battery cables for rubbing or damage.
	•	•	Check TriPac Envidia electric condenser and evaporator fans.

Maintenance Inspection Schedule

Structural

Pretrip	Semi-Annual 1,000 Hrs	Annual 2,000 Hrs	
Check condition of or service the following:			
•	•	•	Visually inspect TriPac Envidia battery box and condenser coil for damaged, loose or broken parts.
		•	Check TriPac Envidia battery box mounting bolts and brackets for cracks, damage and mis-alignment. Verify tightness and torque to 100 ft/lbs (135.6 N•m) for the claw mount, or 200 ft/lbs (271.2 N•m) for the direct frame mount.

Air Conditioning System

Pretrip	Semi-Annual 1,000 Hrs	Annual 2,000 Hrs	
Check condition of or service the following:			
•	•	•	Inspect, clean and (if necessary) replace TriPac Envidia evaporator return air filter. It may be necessary to check or replace it more often if conditions require.
	•	•	Inspect TriPac Envidia evaporator air inlet, outlets, and ducting for obstructions.
	•	•	Inspect TriPac Envidia evaporator drain valves (kazoos) to ensure that they are in place, in good condition and are sealing.

Maintenance Inspection Schedule

Pretrip	Semi-Annual 1,000 Hrs	Annual 2,000 Hrs	
			Check condition of or service the following:
	•	•	Inspect TriPac Envidia condenser coil for debris.
		•	Pressure wash TriPac Envidia condenser coil. <u>Do not bend coil fins or damage with air.</u>
		•	Blow out TriPac Envidia evaporator coil and evaporator water drains with air. <u>Do not bend coil fins or damage with air.</u>
	•	•	Check TriPac Envidia refrigerant lines for rubbing or damage.

Diesel Fuel-Fired Heater

Monthly	Annually	
		Check condition of or service the following:
•	•	Start and run for at least 20 minutes each month.
•	•	Inspect combustion air intake tube and exhaust pipe for restrictions or blockage.
•	•	Inspect ducting, air intake screen, and air outlet for restrictions or blockage.
	•	Remove glow pin and inspect for carbon build up. Clean as needed.
	•	Change fuel pump screen.

TriPac Warranty

Terms of the Thermo King Warranty are available on request. Please reference document TK 50046 for the Thermo King TriPac Envidia Warranty.

Software License

The product includes software that is licensed under a non-exclusive, non-sub-licensable, terminable and limited license to use the software as installed on the product for its intended purpose. Any removal, reproduction, reverse engineering, or other unauthorized use of the software is strictly prohibited. Hacking the product or installing unapproved software may void the warranty. The owner or operator shall not reverse engineer, decompile, or disassemble the software, except and only to the extent that such activity is expressly permitted by applicable law notwithstanding this limitation. The product includes third party software separately licensed as specified in the TPNOTICE file on the Main Controller. The file can be accessed by connecting a computer to the Main Controller with a USB cable.

Serial Number Locations

Battery Box: Unit nameplate is located on upper right front corner of the battery box housing frame near SCM1 (cover must be removed to view the nameplate).

Evaporator/Control Box: Nameplate located on the side of the evaporator/control box near the air conditioning fittings.

Compressor: Nameplate located on compressor body. Not typically visible due to insulation cover. The compressor is located in the TriPac Envidia evaporator/control box.

Heater: Sticker located on the side of the heater (Fabrik No.).

Emergency Cold Line

If you need assistance, and you have tried the Thermo King Container Service Directory (available from any Thermo King dealer) to reach a dealer without success, then call the Toll Free Emergency Marine Cold Line Number (800) 227-2506 or International number +1 (512) 712 1399. The answering service will assist you in reaching a dealer to get the help you need. The Cold Line is answered 24 hours a day by personnel who will do their best to get you quick service at an authorized Thermo King Dealer.



Thermo King – by Trane Technologies (NYSE: TT), a global climate innovator – is a worldwide leader in sustainable transport temperature control solutions. Thermo King has been providing transport temperature control solutions for a variety of applications, including trailers, truck bodies, buses, air, shipboard containers and railway cars since 1938. For more information, visit www.thermoking.com or www.tranetechnologies.com.

Thermo King has a policy of continuous product and product data improvements and reserves the right to change design and specifications without notice. We are committed to using environmentally conscious print practices.